

DEC 10000 AXP System VAX 10000 Site Preparation Guide

Order Number EK-1000B-SP.002

This guide is intended for use by Digital customer service engineers and customers in preparing a site for a DEC 10000 system or a VAX 10000 system.

First Printing, November 1992

The information in this document is subject to change without notice and should not be construed as a commitment by Digital Equipment Corporation.

Digital Equipment Corporation assumes no responsibility for any errors that may appear in this document.

The software, if any, described in this document is furnished under a license and may be used or copied only in accordance with the terms of such license. No responsibility is assumed for the use or reliability of software or equipment that is not supplied by Digital Equipment Corporation or its affiliated companies.

Copyright © 1992 by Digital Equipment Corporation.

All Rights Reserved.
Printed in U.S.A.

The following are trademarks of Digital Equipment Corporation:

Alpha AXP	DECUS	VAXBI
AXP	DWMVA	VAXELN
DEC	OpenVMS	VMScluster
DECchip	ULTRIX	XMI
DEC LANcontroller	UNIBUS	The AXP logo
DECnet	VAX	

OSF/1 is a registered trademark of the Open Software Foundation, Inc.

FCC NOTICE: The equipment described in this manual generates, uses, and may emit radio frequency energy. The equipment has been type tested and found to comply with the limits for a Class A computing device pursuant to Subpart J of Part 15 of FCC Rules, which are designed to provide reasonable protection against such radio frequency interference when operated in a commercial environment. Operation of this equipment in a residential area may cause interference, in which case the user at his own expense may be required to take measures to correct the interference.

Contents

Preface	v
---------------	---

Chapter 1 Site Preparation

1.1	Site Preparation Overview	1-2
1.2	General Description	1-4
1.3	Space Requirements	1-6
1.4	Electrical Requirements	1-8
1.5	Cabling Requirements	1-10
1.6	Environmental Requirements	1-12
1.7	Planning for Delivery	1-15

Figures

1-1	Five-Cabinet System	1-2
1-2	Three-Cabinet System	1-3
1-3	Five-Cabinet System (Front Dimensions)	1-4
1-4	Three-Cabinet System (Front Dimensions)	1-5
1-5	Floor Space Requirements	1-6
1-6	AC Power Inputs	1-8
1-7	Electrical Connectors and Receptacles	1-10
1-8	DEC Power Bus Cable	1-11
1-9	Airflow (System and Expander Cabinets)	1-13
1-10	Floor Cutout Locations (Raised Floors)	1-14

Tables

1	DEC 10000/VAX 10000 Documentation	vii
2	Related Documents	ix
1-1	Free-Standing Cabinet Dimensions and Weights	1-7
1-2	AC Input Voltages	1-9
1-3	Power Requirements and Heat Dissipation	1-9

1-4	Environmental Requirements	1-12
1-5	Shipping Specifications	1-16

Preface

Intended Audience

This manual is written for Digital customer service engineers and customers preparing a site for a DEC 10000 or VAX 10000 system.

Document Structure

This manual uses a structured documentation design. Topics are organized into small sections for efficient on-line and printed reference. Each topic begins with an abstract. You can quickly gain a comprehensive overview by reading only the abstracts. Next is an illustration or example, which also provides quick reference. Last in the structure are descriptive text and syntax definitions.

This manual has one chapter as follows:

- **Chapter 1, Site Preparation**, provides pre-installation requirements and guidelines for DEC 10000 and VAX 10000 systems.

Conventions Used in This Document

Terminology. Unless specified otherwise, the use of "system" refers to either a DEC 10000 AXP or VAX 10000 system. The DEC 10000 AXP systems use the Alpha AXP architecture. References in text use DEC 10000 to refer to DEC 10000 AXP systems.

When a discussion applies to only one system, an icon is used to highlight that system. Otherwise, the discussion applies to both systems. Thus, the abstract for a module that applies only to DEC 10000 systems would look like this:



This section shows a sample boot of OpenVMS Alpha AXP from the RRD42 CD drive for DEC 10000 systems. The first step is issuing the show device command to determine the location of the RRD42.

Book titles. In text, if a book is cited without a product name, that book is part of the hardware documentation. It is listed in Table 1 along with its order number.

Icons. Icons such as those shown below are used in illustrations for designating part placement in the system described. A shaded area in the icon shows the location of the component or part being discussed.

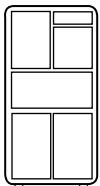

Front

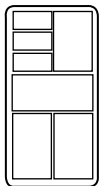

Rear

Documentation Titles

Table 1 lists the books in the DEC 10000 and VAX 10000 documentation set. Table 2 lists other documents that you may find useful.

Table 1 DEC 10000/VAX 10000 Documentation

Title	Order Number
Installation Kit	EK-1000B-DK
<i>Site Preparation Guide</i>	EK-1000B-SP
<i>Installation Guide</i>	EK-100EB-IN
Hardware User Information Kit	EK-1001B-DK
<i>Operations Manual</i>	EK-1000B-OP
<i>Basic Troubleshooting</i>	EK-1000B-TS
Service Information Kit—VAX 10000	EK-1002A-DK
<i>Platform Service Manual</i>	EK-1000A-SV
<i>System Service Manual</i>	EK-1002A-SV
<i>Pocket Service Guide</i>	EK-1000A-PG
<i>Advanced Troubleshooting</i>	EK-1001A-TS
Service Information Kit—DEC 10000	EK-1002B-DK
<i>Platform Service Manual</i>	EK-1000A-SV
<i>System Service Manual</i>	EK-1002A-SV
<i>Pocket Service Guide</i>	EK-1100A-PG
<i>Advanced Troubleshooting</i>	EK-1101A-TS

Table 1 DEC 10000/VAX 10000 Documentation (Continued)

Title	Order Number
Reference Manuals	
<i>Console Reference Manual</i>	EK-70C0B-TM
<i>KA7AA CPU Technical Manual</i>	EK-KA7AA-TM
<i>KN7AA CPU Technical Manual</i>	EK-KN7AA-TM
<i>MS7AA Memory Technical Manual</i>	EK-MS7AA-TM
<i>I/O System Technical Manual</i>	EK-70I0A-TM
<i>Platform Technical Manual</i>	EK-7000A-TM
Upgrade Manuals	
<i>KA7AA CPU Installation Guide</i>	EK-KA7AA-IN
<i>KN7AA CPU Installation Guide</i>	EK-KN7AA-IN
<i>MS7AA Memory Installation Guide</i>	EK-MS7AA-IN
<i>KZMSA Adapter Installation Guide</i>	EK-KXMSX-IN
<i>DWLMA XMI PIU Installation Guide</i>	EK-DWLMA-IN
<i>DWMBB VAXBI PIU Installation Guide</i>	EK-DWMBB-IN
<i>H7237 Battery PIU Installation Guide</i>	EK-H7237-IN
<i>H7263 Power Regulator Installation Guide</i>	EK-H7263-IN
<i>BA654 DSSI Disk PIU Installation Guide</i>	EK-BA654-IN
<i>BA655 SCSI Disk and Tape PIU Installation Guide</i>	EK-BA655-IN
<i>Removable Media Installation Guide</i>	EK-TFRRD-IN

Table 2 Related Documents

Title	Order Number
General Site Preparation	
<i>Site Environmental Preparation Guide</i>	EK-CSEPG-MA
System I/O Options	
<i>BA350 DECstor/me Modular Storage Shelf Subsystem Configuration Guide</i>	EK-BA350-CG
<i>BA350 DECstor/me Modular Storage Shelf Subsystem User's Guide</i>	EK-BA350-UG
<i>BA350-LA DECstor/me Modular Storage Shelf User's Guide</i>	EK-350LA-UG
<i>CIXCD Interface User Guide</i>	EK-CIXCD-UG
<i>DEC FDDIcontroller 400 Installation/Problem Solving</i>	EK-DEMFA-IP
<i>DEC LANcontroller 400 Installation Guide</i>	EK-DEMNA-IN
<i>DEC LANcontroller 400 Technical Manual</i>	EK-DEMNA-TM
<i>DSSI VAXcluster Installation and Troubleshooting Manual</i>	EK-410AA-MG
<i>InfoServer 150 Installation and Owner's Guide</i>	EK-INFSV-OM
<i>KDM70 Controller User Guide</i>	EK-KDM70-UG
<i>KFMSA Module Installation and User Manual</i>	EK-KFMSA-IM
<i>KFMSA Module Service Guide</i>	EK-KFMSA-SV
<i>RRD42 Disc Drive Owner's Manual</i>	EK-RRD42-OM
<i>RF Series Integrated Storage Element User Guide</i>	EK-RF72D-UG
<i>TF85 Cartridge Tape Subsystem Owner's Manual</i>	EK-OTF85-OM
<i>TLZ06 Cassette Tape Drive Owner's Manual</i>	EK-TLZ06-OM

Table 2 Related Documents (Continued)

Title	Order Number
Operating System Manuals	
<i>Alpha Architecture Reference Manual</i>	EY-L520E-DP
<i>DEC OSF/1 Guide to System Administration</i>	AA-PJU7A-TE
<i>DECnet for OpenVMS Network Management Utilities</i>	AA-PQYAA-TK
<i>Guide to Installing DEC OSF/1</i>	AA-PS2DA-TE
<i>OpenVMS Alpha Version 1.0 Upgrade and Installation Manual</i>	AA-PQYSA-TE
<i>VMS Upgrade and Installation Supplement: VAX 7000-600 and VAX 10000-600 Series</i>	AA-PRAHA-TE
<i>VMS Network Control Program Manual</i>	AA-LA50A-TE
VMScusters and Networking	
<i>HSC Installation Manual</i>	EK-HSCMN-IN
<i>SC008 Star Coupler User's Guide</i>	EK-SC008-UG
<i>VAX Volume Shadowing Manual</i>	AA-PBTVA-TE
Peripherals	
<i>Installing and Using the VT420 Video Terminal</i>	EK-VT420-UG
<i>LA75 Companion Printer Installation and User Guide</i>	EK-LA75X-UG

Chapter 1

Site Preparation

This book should be used in conjunction with the *Site Environmental Preparation Guide* (EK-CSEPG-MA). Use the *Guide* for information on the general considerations of planning any site, and use this book for site planning information specific to the system. Sections in this book include:

- Site Preparation Overview
- General Description
- Space Requirements
- Electrical Requirements
- Cabling Requirements
- Environmental Requirements
- Planning for Delivery

1.1 Site Preparation Overview

The tasks that must be performed at a site prior to installation are covered in detail in the *Site Environmental Preparation Guide*. The list that follows is an overview of the site preparation process. Refer to the *Guide* for information on preliminary site preparation.

Figure 1-1 Five-Cabinet System

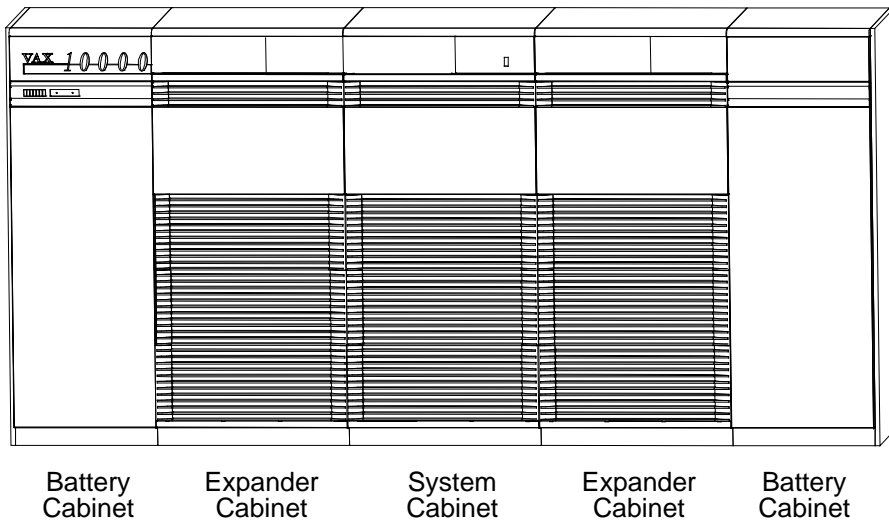

BXB-0031-92

Figure 1-2 Three-Cabinet System

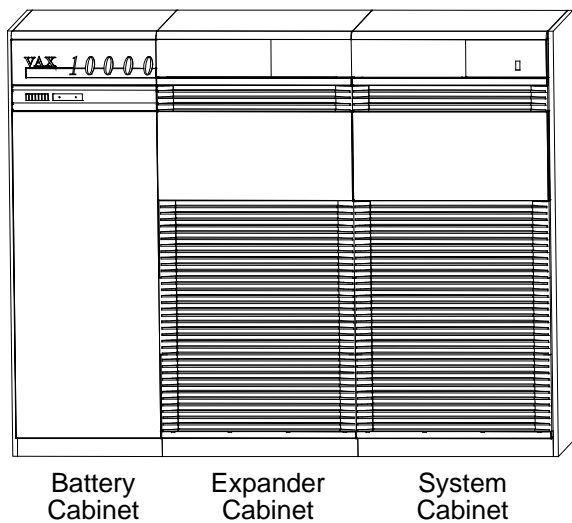

BXB-0047-92

Site Planning Considerations:

- Plan the physical layout of the system cabinet, expander cabinet(s), battery cabinet(s), console terminal, printer, and other system units.
- Plan to place all equipment away from heavy traffic centers, leaving enough room for airflow and maintenance.
- Obtain cabinet weights and dimensions to check against floor loading restrictions.
- Determine the sizes of circuit breakers and the number of branch circuits required.
- Determine the number, type, and location of required AC power outlets.
- Check the compatibility of different power sources. This must be checked when multiple types of power distribution transformers or power conditioning equipment is used.
- Determine system power consumption to calculate the input line power requirement.
- Establish a system grounding scheme for the installation.
- Determine environmental cooling requirements.
- Check the location and requirements of cabling for communication devices such as Ethernet.

1.2 General Description

Systems are available in either a 5-cabinet or a 3-cabinet configuration. The 5-cabinet configuration (Figure 1-3) consists of a system cabinet, two expander cabinets, and two battery cabinets. The 3-cabinet configuration (Figure 1-4) consists of a system cabinet, one expander cabinet, and one battery cabinet.

Figure 1-3 Five-Cabinet System (Front Dimensions)

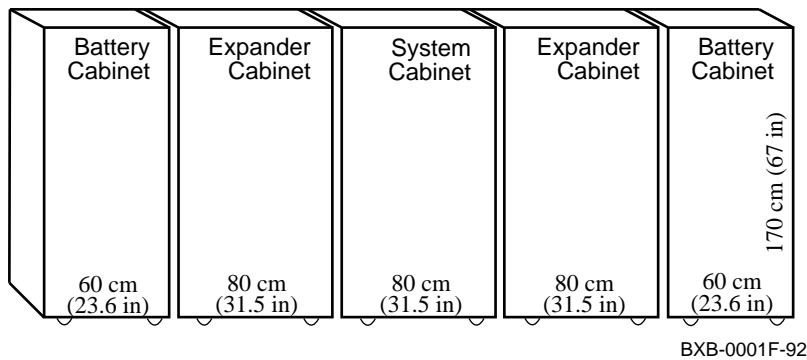
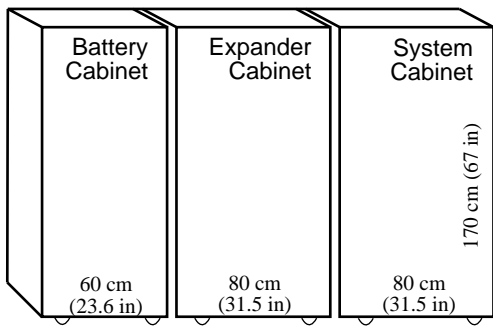

Figure 1-4 Three-Cabinet System (Front Dimensions)



BXB-0001H-92

1.3 Space Requirements

Floor space and floor loading requirements vary according to the number of cabinets in a system, as shown in Figure 1-5 and Table 1-1.

Figure 1-5 Floor Space Requirements

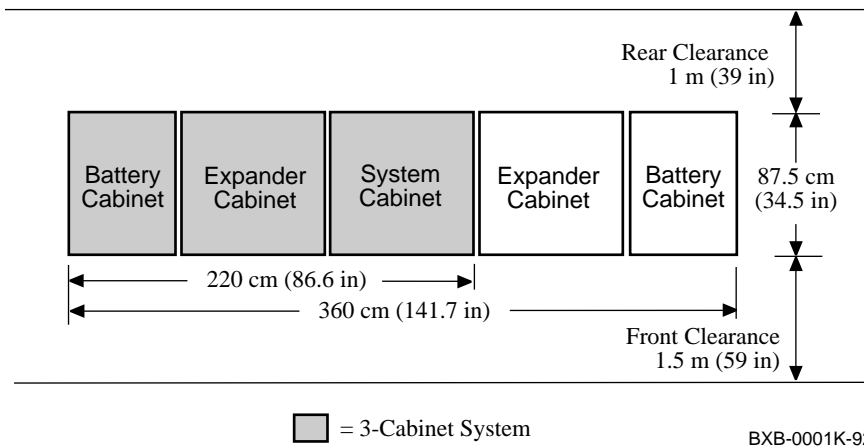

Table 1-1 Free-Standing Cabinet Dimensions and Weights

	Height cm (in)	Width cm (in)	Depth cm (in)	Weight kg (lb)
System:				
3-Cabinet System	170 (67)	220 (86.6)	87.5 (34.5)	1640 (3600)
5-Cabinet System	170 (67)	360 (141.7)	87.5 (34.5)	2600 (5700)
Cabinets:				
System Cabinet	170 (67)	80 (31.5)	87.5 (34.5)	680 (1500)
Expander Cabinet	170 (67)	80 (31.5)	87.5 (34.5)	408 (900)
Battery Cabinet	170 (67)	60 (23.6)	87.5 (34.5)	545 (1200)

1.4 Electrical Requirements

System power is applied to the system cabinet and expander cabinet(s) by AC power cables (Figure 1-6). Table 1-2 shows the AC requirements for 3-cabinet and 5-cabinet systems with various AC input voltages. Table 1-3 summarizes system power requirements.

Figure 1-6 AC Power Inputs

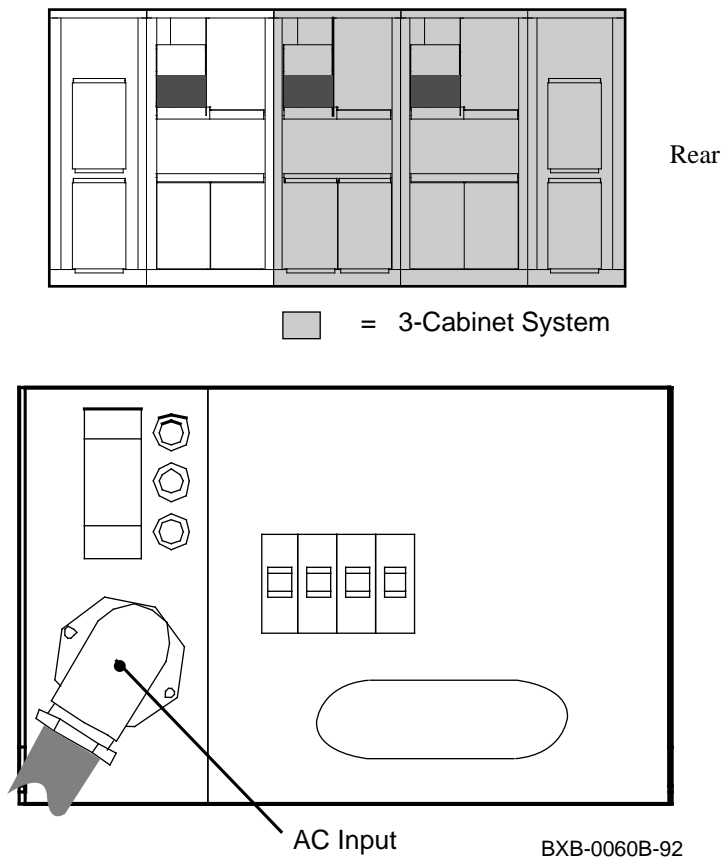

Table 1-2 AC Input Voltages

Country	Input Voltage (Nominal)	Phases	Maximum Input Current Per Phase (rms amps)	Surge Current (peak amps)	Breaker Rating (amps)
North America	120/208 Wye ¹ 50–60 Hz	3-phase star 4-wire N-GND	24	50	30
Europe/ GIA	380–415 Wye ¹ 50–60 Hz	3-phase star 4-wire N-GND	12.8	50	16
Japan	202 Delta ¹ 50–60 Hz	3-phase Delta 4-wire mid-GND 3-wire junction-GND	24	50	30

¹Per line cord.

The 3-cabinet system has two line cords. The 5-cabinet system has three line cords.

Power receptacles are also required for console terminals and printers.

Table 1-3 Power Requirements and Heat Dissipation

System	Watts (Max)	BTU/hr (Max)
3-Cabinet	6,600	22,500
5-Cabinet	10,900	37,200

1.5 Cabling Requirements

AC power cables are 2.8 m (9 ft) in length. Each cable contains three-phase leads (X, Y, and Z) plus neutral (W/N) and ground (G). AC power connectors and receptacles are shown in Figure 1-7. The DEC power bus cable if present must also be planned for (Figure 1-8).

*NOTE: Neutral and ground lines are not interchangeable and must both be individually connected from the bulk three-phase power to complete the Wye configuration. **Power must not be connected to the site until power checks are performed.** See the Installation Guide for more information.*

Figure 1-7 Electrical Connectors and Receptacles

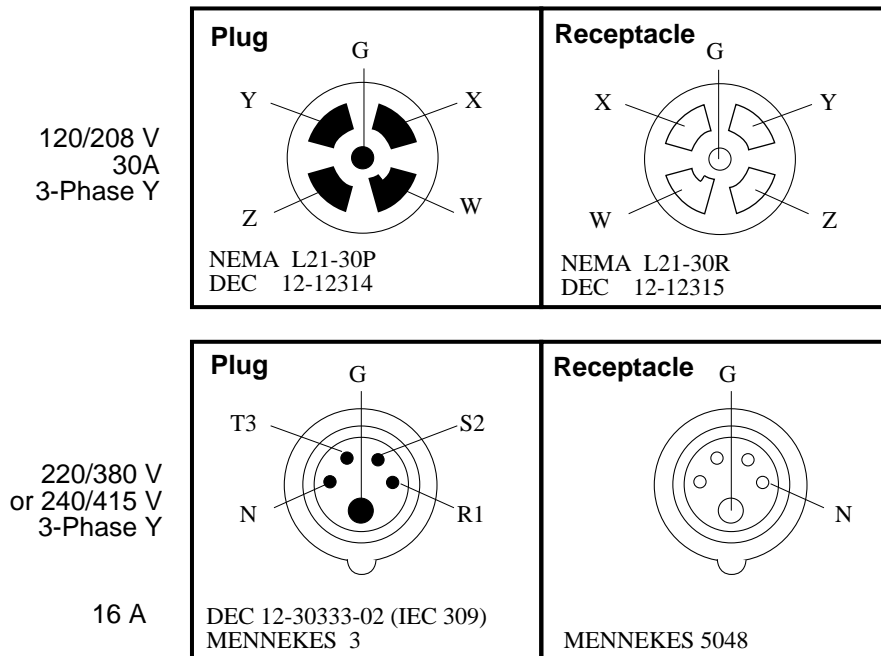

BXB-0002A-92

Figure 1-8 DEC Power Bus Cable

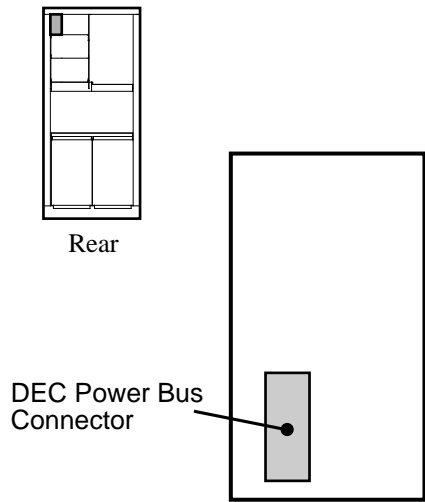

BXB-0061-92

1.6 Environmental Requirements

Environmental factors such as temperature, humidity, altitude, vibration, and airflow must be considered when planning the site. If the site has a raised floor, appropriate floor cutouts must be made for cables (Figure 1-10).

Table 1-4 Environmental Requirements

Condition	Temperature	Relative Humidity	Altitude	Vibration
Operating	15C to 28C 59F to 82F	20% to 80%	0 to 2.4 km 0 to 8000 ft	2 to 22 Hz @ 0.01 " da minimum
Non- Operating	-40C to 66C -40F to 151F	10% to 95%	0 to 9.1 km 0 to 30,000 ft	22 to 500 Hz @ 0.25 g maximum

Figure 1-9 Airflow (System and Expander Cabinets)

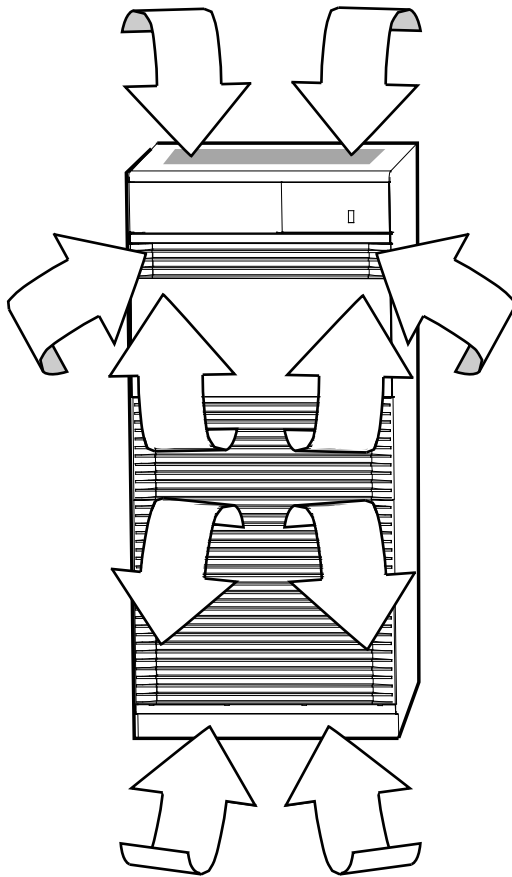

BXB-0056A-92

Air is taken in through the top and bottom of the cabinet by a central dual wheel blower. The air is then circulated through the card cages and power regulators. It is exhausted at the middle of the cabinet front and rear.

NOTE: Do not place anything on top of a cabinet that would block airflow. Inadequate airflow can result in the system shutting down.

Figure 1-10 Floor Cutout Locations (Raised Floors)

3-CABINET SYSTEM

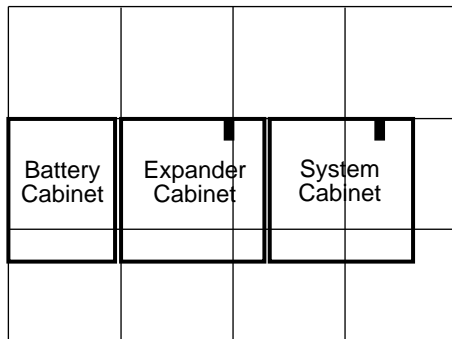

5-CABINET SYSTEM

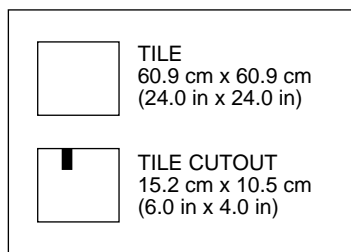
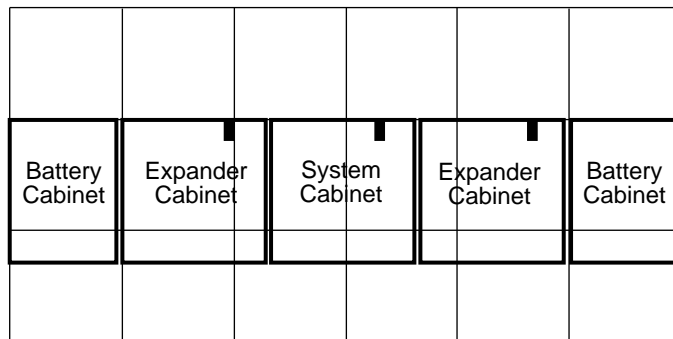

BXB-0051-92

1.7 Planning for Delivery

Prepare the site for delivery of the cabinets (Table 1-5).

Check the delivery route and refer to Table 1-5.

- Check the height, width, and location of doors and passageways for adequate clearance.
- Check floor loading and consider protective covering along passageways.
- Check passageway restrictions such as corners, ramps, or obstructions.
- Check the size, capacity, and availability of elevators.

The system, expander, and battery cabinets are boxed separately. Table 1-5 shows the weight and dimensions of each cabinet with packing materials and mounted on a pallet.

Table 1-5 Shipping Specifications

Cabinet	Shipping Dimensions (Height, Width, Depth)	Shipping Weight (Fully Configured)
System	195 cm x 109.5 cm x 121 cm (76.8 in x 43.1 in x 47.5 in)	720 kg (1600 lbs)
Expander	195 cm x 109.5 cm x 121 cm (76.8 in x 43.1 in x 47.5 in)	448 kg (1000 lbs)
Battery	200 cm x 91 cm x 120 cm (79 in x 36 in x 47.25 in)	585 kg (1300 lbs)

WARNING: *Serious injury may result if cabinets are improperly handled or proper safety conditions are not met. Refer to the Installation Guide for specific unpacking and assembly instructions, and always use at least two people to move a cabinet or to remove it from a skid.*

For more information:

Installation Guide

Index

A

AC power cables, 1-15
AC power connectors, 1-15
AC power receptacles, 1-15
AC sources, 1-9
AC surge currents, 1-9
Altitude requirements, 1-12

C

Cabinet depth, 1-7
Cabinet height, 1-7
Cabinet power requirements, 1-9
Cabinet sizes, 1-10
Cabinet weight, 1-7
Cabinet width, 1-7

E

Environmental requirements, 1-12

H

Humidity, relative requirements,
1-12

P

Pre-installation checklist, 1-6

S

Site preparation, 1-1
System heat dissipation, 1-9
System wattage, 1-9

T

Temperature requirements, 1-12