

VAX 4000

Site Preparation

Order Number: EK-387AH-SP. H01

First Printing, March 1990
Revised, December 1990
Revised, November 1991
Revised, April 1992
Revised, July 1992
Revised, July 1993
Revised, July 1994

The information in this document is subject to change without notice and should not be construed as a commitment by Digital Equipment Corporation.

Digital Equipment Corporation assumes no responsibility for any errors that may appear in this document.

Any software described in this document is furnished under a license and may be used or copied only in accordance with the terms of such license. No responsibility is assumed for the use or reliability of software or equipment that is not supplied by Digital Equipment Corporation or its affiliated companies.

Restricted Rights: Use, duplication, or disclosure by the U.S. Government is subject to restrictions as set forth in subparagraph (c)(1)(ii) of the Rights in Technical Data and Computer Software clause at DFARS 252.227-7013.

Copyright © Digital Equipment Corporation 1990, 1991, 1992, 1993, 1994. All Rights Reserved.

The Reader's Comments form at the end of this document requests your critical evaluation to assist in preparing future documentation.

The following are trademarks of Digital Equipment Corporation: CompacTape, CX, DDCMP, DEC, DECconnect, DECdirect, DECnet, DECscan, DECserver, DECUS, DECwindows, DELNI, DEMPR, DESQA, DESTA, DSRVB, DSSI, IVAX, KDA, KLESI, MicroVAX, MSCP, Q-bus, Q22-bus, RA, RQDX, RRD40, SDI, ThinWire, TK, TMSCP, TQK50, TQK70, TSV05, TU, VAX, VAX 4000, VAXcluster, VAX DOCUMENT, VAXELN, VAXlab, VAXserver, VMS, VT, and the DIGITAL logo.

All other trademarks and registered trademarks are the property of their respective holders.

FCC NOTICE: The equipment described in this manual generates, uses, and may emit radio frequency. The equipment has been type tested and found to comply with the limits for a Class A computing device pursuant to Subpart J of Part 15 of FCC Rules, which are designed to provide reasonable protection against such radio frequency interference.

Operation of the equipment in a residential area may cause interference, in which case the user at his own expense will be required to take whatever measures may be required to correct the interference.

S2575

This document was prepared using VAX DOCUMENT Version 2.1.

Contents

1 General Requirements

1.1	System and Expander Enclosure Designations	1-1
1.2	Space Requirements	1-2
1.3	Operating Environment	1-3
1.3.1	Static Electricity	1-3
1.3.2	Temperature and Humidity Ranges	1-4
1.4	Electrical Requirements	1-4
1.4.1	Power Source	1-4
1.4.2	Grounding	1-5
1.5	Acoustics	1-6
1.6	When Your Shipment Arrives	1-6

2 Specific Requirements

2.1	Dimensions	2-1
2.1.1	BA430/BA440 Enclosure and B400X/R400X Expander Shipping Carton Dimensions	2-2
2.1.2	BA430/BA440 Enclosure and B400X/R400X Expander Dimensions	2-3
2.1.3	BA215 Enclosure and Shipping Carton Dimensions	2-4
2.2	Heat, Humidity, Electrical Requirements, and Acoustics	2-5
2.2.1	BA430/BA440 Enclosure and R400X Expander Specifications	2-5
2.2.2	BA215 Enclosure Specifications	2-7
2.3	Additional Expander Requirements	2-8

A Power and Ground Cable Part Numbers

A.1	Power Cables for BA430/BA440 Enclosure Systems and B400X/R400X Expanders	A-1
A.2	Power Cables for BA215 Enclosure Systems and R215F Expanders	A-2
A.3	Power Cables for SF12 Expanders	A-2
A.4	Ground Cables	A-3

Index

1

General Requirements

Read this chapter for general requirements. Then refer to Chapter 2 for the specific requirements of your system. To ensure smooth installation and operation of the system, your site must meet the requirements in both chapters before the arrival of your system shipment.

Note

Digital recommends that a Digital service representative install your system.

Digital provides a site preparation service. If you want Digital to prepare your site, contact your Digital service or sales representative.

1.1 System and Expander Enclosure Designations

The following table lists the enclosures in which the systems and expanders are shipped. For simplicity, enclosure designations are used throughout this manual rather than the system or expander name. There are other supported expander cabs that are not mentioned here. Refer to the documentation that comes with those units.

System or Expander	Enclosure
VAX 4000 Model 100 System	BA42B
VAX 4000 Model 100A System	BA42B
VAX 4000 Model 105A System	BA42B
VAX 4000 Model 200 System	BA430
VAX 4000 Model 200 System	BA215
VAX 4000 Model 300 System	BA440

System or Expander	Enclosure
VAX 4000 Model 400 System	BA440
VAX 4000 Model 500 System	BA440
VAX 4000 Model 500A System	BA440
VAX 4000 Model 505A System	BA440
VAX 4000 Model 600 System	BA440
VAX 4000 Model 600A System	BA440
VAX 4000 Model 700A System	BA440
VAX 4000 Model 705A System	BA440
B400X Expander	BA430
R400X Expander	R400X
SF12	BA42A

The physical requirements for your system are determined by its dimensions before and after the shipping carton is removed, space for doors to swing open, space for peripheral equipment such as printers and terminals, allowances for adequate airflow around the system, and the noise emission level of the system.

1.2 Space Requirements

Before unpacking your equipment, make sure you have enough space to remove the system from its shipping carton. You need 1.5 to 1.8 meters (5 to 6 feet) to the side of the carton to allow room for rolling the system off its shipping ramp. The BA42 needs less space. Also make sure you leave enough space around the system so it can be serviced. The dimensions of cartons and enclosures are shown in Chapter 2.

You must leave at least 1 meter (39 inches) of clearance at the front of your system for opening the doors and to access system controls. You must also leave at least 5 centimeters (2 inches) of clearance at the sides and rear for airflow. Since the base of the enclosure is 5 centimeters (2 inches) wider than the cabinet in front and rear, you can place the rear of the system against a wall or table, and the system will have enough room for adequate airflow.

In addition to the space required for your system, you should ensure that you have enough space for any expanders, terminals, printers, mass storage media, printer paper, and other necessary supplies.

If you plan to connect your system to peripheral devices such as printers, terminals, or modems, you will need additional cabling. Cables that connect the system to peripheral devices must be ordered separately.

Note

Cabling from peripheral devices should be in place and labeled before your system is installed.

When planning cable routing for multiterminal equipment, you should consider factors such as safety, convenience, future expansion, and cost. And there are other factors to consider when cabling a multiterminal system on more than one floor in the same building or in more than one building. Digital offers several cable types for such applications, and Digital service personnel are available to help you plan your installation. Your sales representative can provide more information.

1.3 Operating Environment

Your system is affected by the discharge of static electricity, temperature changes, and humidity. Those conditions can affect the operation and overall dependability of your system.

1.3.1 Static Electricity

Static electricity is a common problem. It can cause system failure and loss of data. The most common source of static buildup is contact between people and carpeting or clothing. Low humidity allows the greatest buildup of static charges.

To minimize static buildup, follow these guidelines.

- Maintain a relative humidity of at least 40 percent.
- Locate your system away from busy office corridors.
- Avoid using carpeting in the computer area. If you must install carpeting, use antistatic carpeting if possible. If regular carpeting is already installed, place a grounded antistatic mat under your system.
- Maintain the antistatic properties of antistatic floors, carpeting, or mats by following the manufacturer's recommendations for cleaning.

1.3.2 Temperature and Humidity Ranges

Your system should be installed in a well-ventilated area where the temperature and humidity ranges listed in Chapter 2 for your system are maintained throughout the year.

Rapid temperature changes may affect system performance. Therefore, do not operate your system near heating or cooling devices, large windows, or doors that open to the outside. Air should contain a minimum of dust and other abrasive contaminants.

Mass storage media and other computer supplies, including paper, should be kept at the same temperature and humidity as that of the computer area.

When calculating the operating temperature in your environment, consider the heat that the system, peripherals, and other equipment generate. See Chapter 2 for the amount of heat dissipated by each system and expander.

1.4 Electrical Requirements

In determining the electrical requirements of your system or expander, consider the following.

- Voltage range
- Power-source phase
- Nominal frequency
- Frequency range
- Steady-state current
- Power consumption

When you are ready to use that information, turn to Chapter 2 and find the electrical requirements for your system.

1.4.1 Power Source

The power source should handle your system and allow for system expansion. Digital recommends a dedicated circuit from the power source for each system and a separate dedicated circuit for each expander. A dedicated ground circuit provides electrical isolation from power surges or electrical noise caused by other electrical equipment. You should not connect any other equipment such as air conditioners, office copiers, or coffee pots to the same circuit as your system or expander.

If you cannot avoid power disturbances, your system will need additional power-conditioning equipment. For more information, contact your Digital sales representative.

Each system shipped within North America includes a 120-Vac power cable. If your system will be shipped outside North America, or if you require a 240-Vac cable, you must order the power cable(s) separately. See the appendix for a list of the countries and their associated power cables.

1.4.2 Grounding

If you will be installing two or more enclosures (system or expander) and if they will be connected by a common DSSI bus, improper grounding can result in voltage potentials, called ground offset voltages, between the enclosures. And if those voltages exceed certain limits, data transmission across the DSSI bus can be disrupted and your system can experience performance degradation or data corruption.

To prevent system performance degradation or data corruption caused by excessive ground offset voltages:

1. Have a qualified electrician check to make sure your site power distribution system meets all local electrical codes.
2. Also have that electrician inspect your entire site power distribution system to make sure it does not have any of these faults.
 - a. Outlets do not have power ground connections.
 - b. Grounding prong missing from computer equipment power cables.
 - c. Power outlet neutral connections are actually ground connections.
 - d. Grounds for the power outlets are not connected to the same power distribution panel.
 - e. Devices that are not UL or IEC approved are connected to the same circuit breaker as the computer equipment.

If all the requirements in steps 1 and 2 are met, the ground offset voltages should be within acceptable limits for DSSI operation. If any of those requirements cannot be met, after your system is installed and turned on you should check the ground offset voltages as described in the system *Installation* manual.

Note

To ensure proper grounding, you should check the ground offset voltages even if all the requirements in steps 1 and 2 are met.

1.5 Acoustics

Computer systems generate noise. Higher than acceptable noise levels can adversely affect your work environment. Digital recommends placing your system and B400X, R400X, B213F expanders in an open office environment.

1.6 When Your Shipment Arrives

When your system arrives, you should inspect it with a Digital service representative to ensure that the system and all ordered options arrived undamaged.

When you are ready to begin installation, find the Customer Hardware Information Kit (in the system shipping carton) and begin using the *Installation* manual and *Installation Checklist* to install your system.

2

Specific Requirements

This chapter lists system dimensions, acceptable temperature and humidity ranges, electrical requirements, and acoustic levels to consider in preparing your site.

2.1 Dimensions

Your system and B400X, R400X expanders are shown in this section with their shipping carton dimensions and enclosure dimensions.

WARNING

To prevent injury, at least two people should move system, expander, or terminal cartons.

- Section 2.1.1 shows the dimensions of the carton used to ship BA430 and BA440 systems and R400X and B400X expanders.
- Section 2.1.2 shows the dimensions of systems and expanders that use the BA430 or BA440 enclosure.
- Section 2.1.3 shows the dimensions of the carton used to ship the Model 200 (BA215) system.

2.1.1 BA430/BA440 Enclosure and B400X/R400X Expander Shipping Carton Dimensions

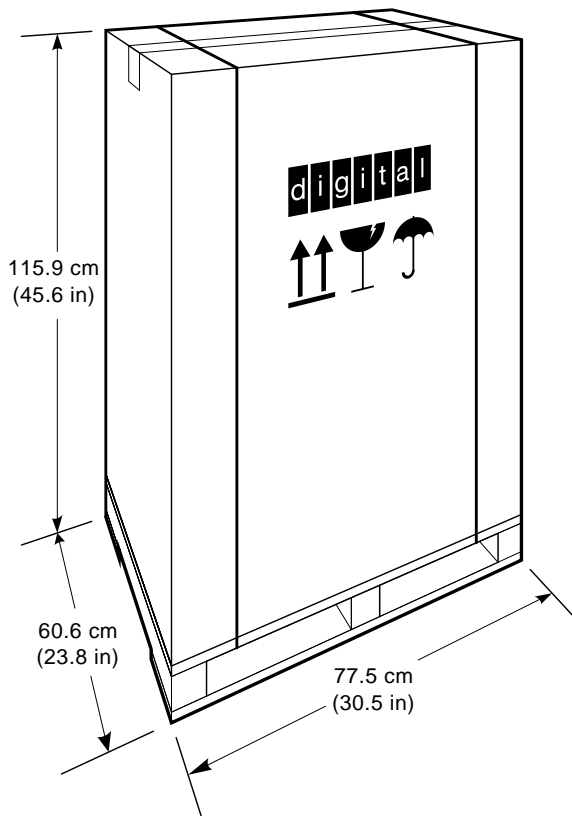

WEIGHT: 63.5 kg to 85.3 kg
(140 lb to 188 lb)

MLO-004189

2.1.2 BA430/BA440 Enclosure and B400X/R400X Expander Dimensions

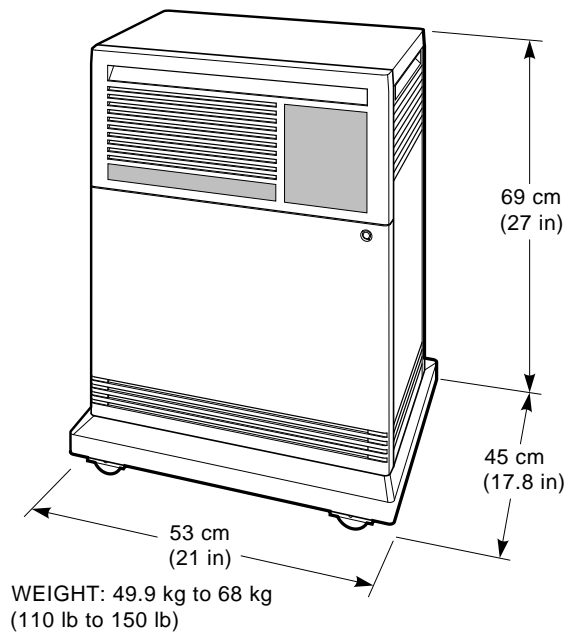

MLO-004190

2.1.3 BA215 Enclosure and Shipping Carton Dimensions

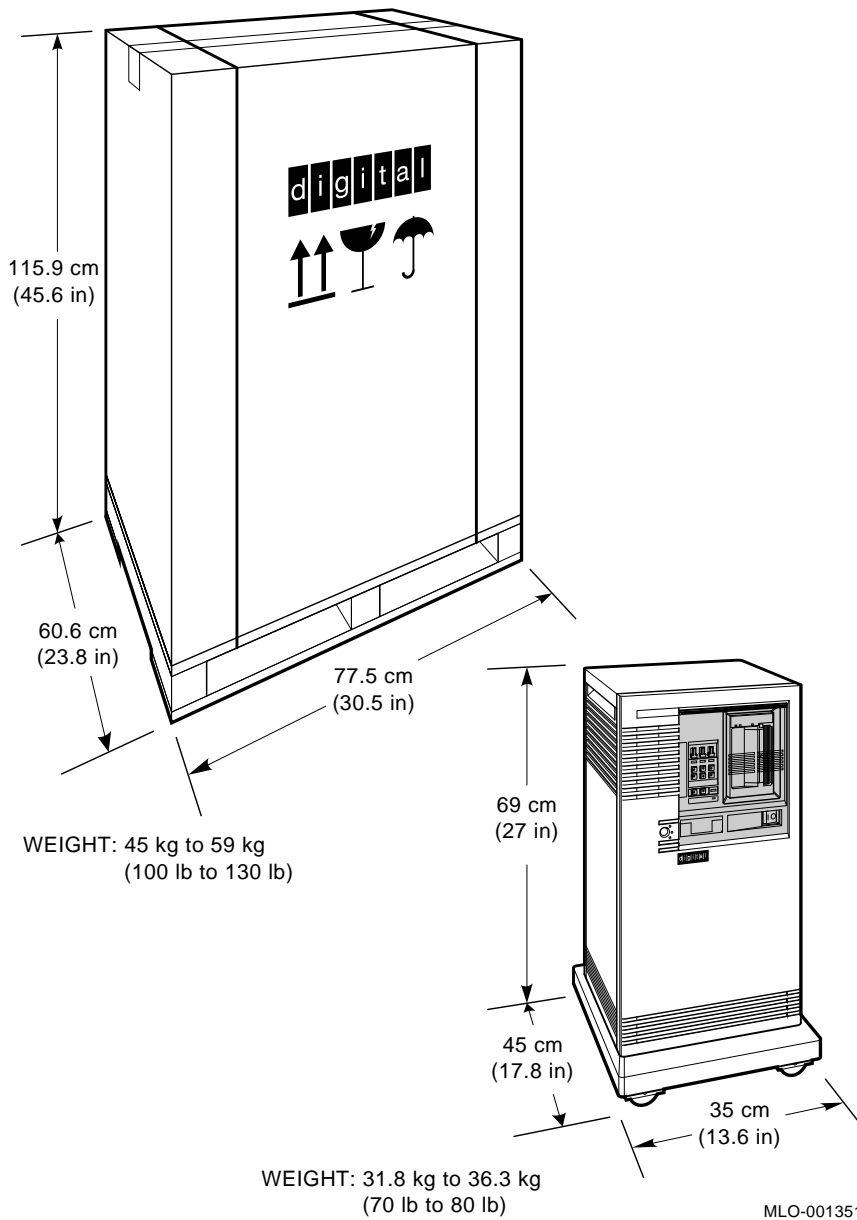

2.2 Heat, Humidity, Electrical Requirements, and Acoustics

Systems and expanders operate within or at the values for temperature and humidity, power requirements, and noise levels listed in the following sections.

- Section 2.2.1, BA430/BA440 enclosure and R400X expander specifications
- Section 2.2.2, BA215 enclosure specifications

2.2.1 BA430/BA440 Enclosure and R400X Expander Specifications

Heat Dissipation, Temperature, and Humidity Ranges

Condition		Measure
Heat dissipation	—	2980 BTU/h
Temperature	Operating:	10°C to 40°C (50°F to 104°F)
	Nonoperating:	–40°C to 66°C (–40°F to 151°F)
Temperature rate of change	Operating:	11°C (20°F) per hour maximum
Relative humidity	Operating:	20% to 80% noncondensing
	Nonoperating:	10% to 90% noncondensing
Maximum altitude	Operating:	2438 meters (8000 feet)
	Nonoperating:	4877 meters (16,000 feet)

NOTE: For operation above sea level, decrease the operating temperature range values by 1.8°C per 1000 meters (1°F per 1000 feet).

Operating Acoustic Emission Levels

LNPE (B)	LPA (dB)
6.6	61
Recommended placement:	Office environment

NOTES:

LNPE = Noise power emission level (A-weighted sound power level) measured in bels reference 1 pico-watt

LPA = Sound pressure measured in decibels at 1.0 meter from the front edge of the unit and 1.5 meters above the floor.

Levels may be lower than those shown, depending on the kind and number of mass storage devices in the system.

All data measured in accordance with ANSI S12.10-1985 (American National Standards Institute) and ISO/DIS 7779 (International Standards Organization).

Electrical Requirements

Nominal AC Voltage ⇒	100 to 120 Vac	220 to 240 Vac
Voltage range	90 to 128 Vac	176 to 264 Vac
Power-source phase	Single	Single
Nominal frequency	50 to 60 Hz	50 to 60 Hz
Frequency range	47 to 63 Hz	47 to 63 Hz
Maximum steady-state current at nominal voltage	11.9 A	5.8 A
Maximum steady-state current at minimum voltage	11.9 A	5.8 A
Maximum inrush current	100 A	83 A
Maximum power consumption	850 W	850 W

2.2.2 BA215 Enclosure Specifications

Heat Dissipation, Temperature, and Humidity Ranges

Condition		Measure
Heat dissipation	—	1178 BTU/h
Temperature	Operating:	10°C to 40°C (50°F to 104°F)
	Nonoperating:	–40°C to 66°C (–40°F to 151°F)
Temperature rate of change	Operating:	11°C (19.8°F) per hour maximum
Relative humidity	Operating:	20% to 80% noncondensing
	Nonoperating:	10% to 90% noncondensing
Maximum altitude	Operating:	2438 meters (8000 feet)
	Nonoperating:	4877 meters (16,000 feet)

NOTE: For operation above sea level, decrease the operating temperature range values by 1.8°C per 1000 meters (1°F per 1000 feet).

Operating Acoustic Emission Levels

LNPE (B)	LPA (dB)
6.1	48
Recommended placement:	Office environment

NOTES:

LNPE = Noise power emission level (A-weighted sound power level) measured in bels reference 1 pico-watt

LPA = Sound pressure measured in decibels at 1.0 meter from the front edge of the unit and 1.5 meters above the floor.

Levels may be lower than those shown, depending on the kind and number of mass storage devices in the system.

All data measured in accordance with ANSI S12.10–1985 (American National Standards Institute) and ISO/DIS 7779 (International Standards Organization).

Electrical Requirements

Nominal AC Voltage ⇒	101 Vac	120 Vac	220–240 Vac
Voltage range	88 to 110 Vac	93 to 132 Vac	176 to 264 Vac
Power-source phase	Single	Single	Single
Nominal frequency	50 to 60 Hz	50 to 60 Hz	50 to 60 Hz
Frequency range	47 to 63 Hz	47 to 63 Hz	47 to 63 Hz

Nominal AC Voltage ⇒	101 Vac	120 Vac	220–240 Vac
Maximum steady-state current at nominal voltage	5.2 A	4.4 A	2.4 A
Maximum steady-state current at minimum voltage	8.3A	7.2 A	3.9 A
Maximum inrush current	50 A	50 A	50 A
Startup current (30 seconds) at nominal voltage	7.1 A	5.9 A	3.1 A
Maximum power consumption	340 W	340 W	340 W

2.3 Additional Expander Requirements

An expander in your system has the following additional requirements.

- B400X, R400X expanders require dedicated wall outlets.
- B400X, R400X expanders must be installed by a Digital service representative when the system or expander is not part of a factory-configured system.

See the appendix for the required power cables.

A

Power and Ground Cable Part Numbers

Refer to the sections in this appendix and locate your system. Then order the power cable listed for your country.

Ground cables are listed in Section A.4.

For more information on 240-Vac operation, check with your Digital sales representative.

A.1 Power Cables for BA430/BA440 Enclosure Systems and B400X/R400X Expanders

Part Number	Country
BN20A-2E	United States, Japan, Canada (120 Vac)
BN20B-2E	United States, Japan, Canada (240 Vac)
BN22C-2E	Australia, New Zealand (240 Vac)
BN22D-2E	Central Europe (240 Vac)
BN22E-2E	United Kingdom, Ireland (240 Vac)
BN22F-2E	Switzerland (220 Vac)
BN22H-2E	Denmark (220 Vac)
BN22J-2E	Italy (240 Vac)
BN22K-2E	India (240 Vac)
BN22L-2E	Israel (240 Vac)

Note

A 120-Vac power cable, BN20A-2E, is shipped with each 120-Vac system.

A.2 Power Cables for BA215 Enclosure Systems and R215F Expanders

Part Number	Country
BN20M-2E	United States (120 Vac)
BN20N-2E	United States, Japan, Canada (240 Vac)
BN19J-2E	Australia, New Zealand (230/240 Vac)
BN03B-2E	Central Europe (240 Vac)
BN19B-2E	United Kingdom, Ireland (240 Vac)
BN19F-2E	Switzerland (220 Vac)
BN19L-2E	Denmark (220 Vac)
BN19T-2E	India (240 Vac)
BN19Y-2E	Israel (240 Vac)
BN19N-2E	Italy (240 Vac)

Note

A 120-Vac power cable, BN20M-2E, is shipped with each 120-Vac system.

A.3 Power Cables for SF12 Expanders

Part Number	Country
BN19P-2E	United States (included with each 120-Vac system)
BN19P-1K	United States, Japan, Canada (240 Vac)
BN19H-2E	Australia, New Zealand (240 Vac)
BN19C-2E	Central Europe (240 Vac)
BN19A-2E	United Kingdom, Ireland (240 Vac)
BN19E-2E	Switzerland (240 Vac)
BN19K-2E	Denmark (240 Vac)
BN19Z-2E	Italy (240 Vac)
BN19S-2E	India, South Africa (240 Vac)
BN19U-2E	Israel (240 Vac)

Note

A 120-Vac power cable, BN19P-2E, is shipped with each 120-Vac system.

A.4 Ground Cables

Part Number	Description
BC21G-50	15.24 meter (50 foot) #6 grounding strap
BC21G-25	7.62 meter (25 foot) #6 grounding strap

Index

A

Acoustics, 1-6, 2-5
Arrival, shipment, 1-6

B

B400X/R400X expander dimensions, 2-3
B400X/R400X expander power cables,
A-1
B400X/R400X expander shipping carton
dimensions, 2-2
BA215 enclosure and shipping carton
dimensions, 2-4
BA215 enclosure specifications, 2-7
BA215 enclosure system and R215F
expander power cables, A-2
BA430/BA440 enclosure and B400X
/R400X expander dimensions, 2-3
BA430/BA440 enclosure and B400X
/R400X expander shipping carton
dimensions, 2-2
BA430/BA440 enclosure and R400X
expander specifications, 2-5
BA430/BA440 enclosure system and
B400X/R400X expander power cables,
A-1

C

Cable part numbers
ground, A-3
power and ground, A-1

D

Dimensions, 2-1

E

Electrical requirements, 1-4, 2-5
Electricity, static, 1-3
Enclosure designations, system and
expander, 1-1
Environment, operating, 1-3
Expander enclosure designations, 1-1
Expander requirements, 2-8

G

General requirements, 1-1
Ground cable part numbers, A-1, A-3

H

Heat, humidity, electrical requirements,
and acoustics, 2-5
Humidity, 2-5
Humidity range, 1-4

O

Operating environment, 1-3

P

Part numbers

- ground cables, A-3
- power and ground cables, A-1

Power cable part numbers, A-1

Power cables

- B400X/R400X expanders, A-1
- BA215 enclosure systems and R215F expanders, A-2
- BA430/BA440 enclosure systems and B400X/R400X expanders, A-1
- R215F expanders, A-2
- R400X expanders, A-1
- SF12 expanders, A-2

R

R215F expander power cables, A-2

R400X expander dimensions, 2-3

R400X expander power cables, A-1

R400X expander shipping carton dimensions, 2-2

R400X expander specifications, 2-5

Requirements

- electrical, 1-4, 2-5
- expander, 2-8
- general, 1-1
- space, 1-2
- specific, 2-1

S

SF12 expander power cables, A-2

Shipment arrival, 1-6

Shipping carton dimensions

- B400X/R400X expander, 2-2
- BA215 enclosure, 2-4
- BA430/BA440 enclosure and B400X/R400X expander, 2-2

Space requirements, 1-2

Specific requirements, 2-1

Static electricity, 1-3

System and expander enclosure designations, 1-1

T

Temperature and humidity ranges, 1-4

Reader's Comments

VAX 4000
Site Preparation
EK-387AH-SP. H01

Your comments and suggestions help us improve the quality of our publications.

Thank you for your assistance.

I rate this manual's:	Excellent	Good	Fair	Poor
Accuracy (product works as manual says)	<input type="checkbox"/>	<input type="checkbox"/>	<input type="checkbox"/>	<input type="checkbox"/>
Completeness (enough information)	<input type="checkbox"/>	<input type="checkbox"/>	<input type="checkbox"/>	<input type="checkbox"/>
Clarity (easy to understand)	<input type="checkbox"/>	<input type="checkbox"/>	<input type="checkbox"/>	<input type="checkbox"/>
Organization (structure of subject matter)	<input type="checkbox"/>	<input type="checkbox"/>	<input type="checkbox"/>	<input type="checkbox"/>
Figures (useful)	<input type="checkbox"/>	<input type="checkbox"/>	<input type="checkbox"/>	<input type="checkbox"/>
Examples (useful)	<input type="checkbox"/>	<input type="checkbox"/>	<input type="checkbox"/>	<input type="checkbox"/>
Index (ability to find topic)	<input type="checkbox"/>	<input type="checkbox"/>	<input type="checkbox"/>	<input type="checkbox"/>
Page layout (easy to find information)	<input type="checkbox"/>	<input type="checkbox"/>	<input type="checkbox"/>	<input type="checkbox"/>

I would like to see more/less _____

What I like best about this manual is _____

What I like least about this manual is _____

I found the following errors in this manual:

Page	Description
_____	_____
_____	_____
_____	_____

Additional comments or suggestions to improve this manual:

For software manuals, please indicate which version of the software you are using: _____

Name/Title _____ Dept. _____

Company _____ Date _____

Mailing Address _____

Phone _____

Do Not Tear - Fold Here and Tape

digital™

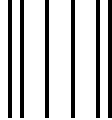

No Postage
Necessary
If Mailed
in the
United States

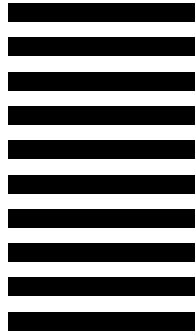

BUSINESS REPLY MAIL
FIRST CLASS PERMIT NO. 33 MAYNARD MASS.

POSTAGE WILL BE PAID BY ADDRESSEE

DIGITAL EQUIPMENT CORPORATION
Information Design and Consulting
MRO1-3/K10
200 FOREST STREET
MARLBORO, MA 01752-3011



Do Not Tear - Fold Here