

# **VAX 6000 Platform Service Manual**

Order Number EK-600EA-MG-001

This manual is intended for Digital customer service engineers. It covers the removal and replacement of field-replaceable units (FRUs) in the H9657-CA/CB/ CU cabinet.

**digital equipment corporation  
maynard, massachusetts**

---

**First Printing, December 1990**

The information in this document is subject to change without notice and should not be construed as a commitment by Digital Equipment Corporation.

Digital Equipment Corporation assumes no responsibility for any errors that may appear in this document.

The software, if any, described in this document is furnished under a license and may be used or copied only in accordance with the terms of such license. No responsibility is assumed for the use or reliability of software or equipment that is not supplied by Digital Equipment Corporation or its affiliated companies.

Copyright ©1990 by Digital Equipment Corporation.

All Rights Reserved.  
Printed in U.S.A.

---

The following are trademarks of Digital Equipment Corporation:

DEMNA	PDP	VAXcluster
DEC	ULTRIX	VAXELN
DEC LANcontroller	UNIBUS	VMS
DECnet	VAX	XMI
DECUS	VAXBI	

**FCC NOTICE:** The equipment described in this manual generates, uses, and may emit radio frequency energy. The equipment has been type tested and found to comply with the limits for a Class A computing device pursuant to Subpart J of Part 15 of FCC Rules, which are designed to provide reasonable protection against such radio frequency interference when operated in a commercial environment. Operation of this equipment in a residential area may cause interference, in which case the user at his own expense may be required to take measures to correct the interference.

---

# Contents

---

Preface	xi
---------	----

---

## Chapter 1 Introduction

---

1.1 System Physical Description	1-2
1.2 System Front View	1-6
1.3 System Rear View	1-8
1.4 Field-Replaceable Units	1-10

## Chapter 2 XMI Card Cage

---

2.1 XMI Card Cage Description	2-2
2.1.1 System Use	2-2
2.1.2 XMI Card Cage Specifications	2-4
2.2 Removing the XMI Card Cage	2-6
2.2.1 Prepare for Removal	2-6
2.2.2 Remove the XMI Card Cage from the Cabinet	2-10
2.2.3 Remove the Daughter Card	2-12
2.3 Replacing the XMI Card Cage	2-14
2.3.1 Attach the Daughter Card	2-14
2.3.2 Install the Card Cage, Attach the Cables, and Insert the Modules	2-16
2.4 Configuring Modules in Model 300 and 400 Systems	2-18
2.5 Configuring Modules in Model 500 Systems	2-20
2.6 XMI Troubleshooting	2-22

## Chapter 3 VAXBI Card Cage

---

3.1	VAXBI Card Cage Description . . . . .	3-2
3.1.1	System Use . . . . .	3-2
3.1.2	VAXBI Card Cage Specifications . . . . .	3-4
3.1.3	VAXBI Card Cage Subassemblies . . . . .	3-6
3.2	Removing the VAXBI Card Cage . . . . .	3-8
3.2.1	Prepare for Removal . . . . .	3-8
3.2.2	Remove the VAXBI Card Cages from the Cabinet . . . . .	3-10
3.2.3	Remove the VAXBI Bus Bars and FBE . . . . .	3-12
3.2.4	Remove Other VAXBI Parts . . . . .	3-14
3.3	Replacing the VAXBI Card Cage . . . . .	3-16
3.3.1	Install VAXBI Parts . . . . .	3-16
3.3.2	Install the Card Cages in the Cabinet . . . . .	3-18
3.4	VAXBI Expansion and Configuration Rules . . . . .	3-20
3.5	VAXBI Troubleshooting . . . . .	3-22

## Chapter 4 System Control Assembly

---

4.1	System Control Assembly Specifications . . . . .	4-2
4.2	System Control Assembly Removal and Replacement . . . . .	4-4
4.3	XTC Power Sequencer Specifications . . . . .	4-8
4.4	XTC Removal and Replacement . . . . .	4-10
4.5	Control Panel Assembly Specifications . . . . .	4-12
4.6	Control Panel Assembly Removal and Replacement . . . . .	4-14
4.7	Filter Board and TOY Clock Battery Specifications . . . . .	4-16
4.8	Filter Board and TOY Clock Battery Removal and Replacement . . . . .	4-18
4.9	Tape Drive Specifications . . . . .	4-20
4.10	Tape Drive Removal and Replacement . . . . .	4-22

## Chapter 5 Power Subsystem

---

5.1	Power Subsystem Design . . . . .	5-2
5.2	Power Specifications . . . . .	5-4
5.3	Power Modules . . . . .	5-6
5.4	H7214 Power Regulator . . . . .	5-8
5.5	H7214 Power Regulator Removal and Replacement . . . . .	5-10
5.6	H7215 Power Regulator . . . . .	5-12
5.7	H7215 Power Regulator Removal and Replacement . . . . .	5-14
5.8	H7242 Power Regulator . . . . .	5-16
5.9	H7242 Power Regulator Removal and Replacement . . . . .	5-18
5.10	H7206-B Power and Logic Unit . . . . .	5-20
5.10.1	Specifications . . . . .	5-20
5.10.2	H7206-B Power and Logic Unit Switches and Indicators . . . . .	5-22
5.11	H7206-B Power and Logic Unit Removal and Replacement . . . . .	5-24
5.12	H7206-B Fan Removal and Replacement . . . . .	5-26
5.13	H405 AC Power Controller . . . . .	5-28
5.14	H405 AC Power Controller Removal and Replacement . . . . .	5-30
5.15	50 Hz Transformer . . . . .	5-32
5.16	50 Hz Transformer Removal and Replacement . . . . .	5-34
5.17	H7236-A Battery Backup Unit . . . . .	5-36
5.18	H7236-A Battery Backup Unit Removal and Replacement . . . . .	5-38
5.18.1	Fan Removal and Replacement . . . . .	5-38
5.18.2	Battery Pack Removal . . . . .	5-40
5.18.3	Battery Pack Replacement . . . . .	5-42
5.18.4	Enclosure Removal and Replacement . . . . .	5-44

## Chapter 6 Cabinet and Airflow Subsystem

---

6.1	Door and Filter Removal and Replacement (Front) . . . . .	6-2
6.2	Door and Filter Removal and Replacement (Rear) . . . . .	6-4
6.3	Airflow Sensor Removal and Replacement . . . . .	6-6
6.4	Temperature Sensor Removal and Replacement . . . . .	6-8
6.5	Blower Assembly Specifications . . . . .	6-10
6.6	Blower Assembly, Front and Rear . . . . .	6-12
6.7	Blower Assembly Removal and Replacement . . . . .	6-14
6.8	Side Panel Removal . . . . .	6-16

## Appendix A Cable List

---

## Appendix B XMI Backplane Connectors

---

## Appendix C Module Handling

---

C.1	Handling Modules .....	C-2
C.2	Inserting Modules .....	C-4

## Appendix D VAX 6000 Platforms

---

## Index

---

## Figures

---

1-1	Sample <REFERENCE>(VAX_XXXX) System .....	1-2
1-2	System Front View .....	1-6
1-3	System Rear View .....	1-8
2-1	XMI Card Cage Connections .....	2-2
2-2	XMI Card Cage .....	2-4
2-3	XMI Backplane Cables and Power Connections .....	2-6
2-4	Control/Status Cable .....	2-8
2-5	XMI Backplane Diagram .....	2-9
2-6	XMI Card Cage .....	2-10
2-7	XMI Daughter Card .....	2-12
2-8	XMI Daughter Card .....	2-14
2-9	XMI Card Cage .....	2-16
2-10	Numbering of XMI Slots .....	2-18
2-11	XMI Configuration Rules for Models 300 and 400 .....	2-19
2-12	Numbering of XMI Slots .....	2-20
2-13	XMI Configuration Rules for Model 500 .....	2-21
3-1	VAXBI Card Cage Connections .....	3-2
3-2	VAXBI Card Cages .....	3-4
3-3	VAXBI Card Cage Subassemblies .....	3-6

3-4	VAXBI Backplane Cables and Power Connections . . . . .	3-8
3-5	VAXBI Card Cages . . . . .	3-10
3-6	VAXBI Bus Bar Assembly . . . . .	3-12
3-7	VAXBI Flexible Backplane Extension . . . . .	3-13
3-8	VAXBI Backplane Components . . . . .	3-14
3-9	VAXBI Cage Mounting Plates . . . . .	3-15
3-10	Installation of Foam Air Seals . . . . .	3-16
3-11	VAXBI Card Cages . . . . .	3-18
3-12	Numbering of VAXBI Slots . . . . .	3-20
4-1	System Control Assembly . . . . .	4-2
4-2	System Control Assembly Removal (Rear) . . . . .	4-4
4-3	System Control Assembly Removal (Front) . . . . .	4-6
4-4	XTC Power Sequencer . . . . .	4-8
4-5	XTC Power Sequencer Removal . . . . .	4-10
4-6	Control Panel Assembly . . . . .	4-12
4-7	Control Panel Assembly Removal . . . . .	4-14
4-8	Filter Board and TOY Clock Battery . . . . .	4-16
4-9	Filter Board and TOY Clock Battery Removal . . . . .	4-18
4-10	Tape Drive . . . . .	4-20
4-11	Tape Drive Removal . . . . .	4-22
5-1	Power Subsystem Design . . . . .	5-2
5-2	DC Power Regulators in Cabinet (Rear View) . . . . .	5-4
5-3	Location of Power Modules (Rear View) . . . . .	5-6
5-4	H7214 Power Regulators (Rear View) . . . . .	5-8
5-5	H7214 Power Regulator Removal . . . . .	5-10
5-6	H7215 Power Regulators (Rear View) . . . . .	5-12
5-7	H7215 Power Regulator Removal . . . . .	5-14
5-8	H7242 Power Regulator (Rear View) . . . . .	5-16
5-9	H7242 Power Regulator Removal . . . . .	5-18
5-10	H7206-B Power and Logic Unit (Rear View) . . . . .	5-20
5-11	H7206-B Power and Logic Unit Switches and Indicators . . . . .	5-22
5-12	H7206-B Power and Logic Unit Removal (Top View) . . . . .	5-24
5-13	H7206-B Fan Removal . . . . .	5-26
5-14	H405 AC Power Controller (Rear View) . . . . .	5-28
5-15	H405 AC Power Controller Removal . . . . .	5-30
5-16	50 Hz Transformer (Front View) . . . . .	5-32

5-17	50 Hz Transformer Removal . . . . .	5-34
5-18	H7236-A Battery Backup Unit (Front View) . . . . .	5-36
5-19	H7236-A Battery Backup Unit (Rear View) . . . . .	5-38
5-20	H7236-A BBU Fan Removal . . . . .	5-39
5-21	H7236-A BBU Battery Pack Removal . . . . .	5-40
5-22	H7236-A Battery Backup Unit (Front View) . . . . .	5-42
5-23	H7236-A BBU Enclosure Removal . . . . .	5-44
6-1	Front Door (Inside View) . . . . .	6-2
6-2	Rear Door (Inside View) . . . . .	6-4
6-3	Airflow Sensor (Front View) . . . . .	6-6
6-4	Temperature Sensor (Front View) . . . . .	6-8
6-5	Blower Assembly . . . . .	6-10
6-6	Front Blower . . . . .	6-12
6-7	Rear Blower . . . . .	6-13
6-8	Blower Assembly Removal (Rear View) . . . . .	6-14
6-9	Side Panel Removal (Front View) . . . . .	6-16
B-1	XMI Backplane Connector Numbering . . . . .	B-1
C-1	Holding VAX 6000 Series Processor Modules . . . . .	C-2
C-2	Inserting the Scalar Processor in an XMI Card Cage . . . . .	C-4
C-3	Inserting the Vector Processor in an XMI Card Cage . . . . .	C-4

## Tables

---

1	VAX 6000 Series Documentation . . . . .	xiii
2	VAX 6000 Model Level Documentation . . . . .	xiv
3	Associated Documents . . . . .	xiv
1-1	<REFERENCE>(VAX_XXXX) Series System Characteristics . . . . .	1-4
1-2	Field-Replaceable Units . . . . .	1-10
2-1	XMI Card Cage Assembly Specifications . . . . .	2-4
2-2	XMI Card Cage Cables and Parts . . . . .	2-5
2-3	XMI Troubleshooting Checklist . . . . .	2-22
2-4	XMI Connector Cleaning Supplies . . . . .	2-23
3-1	VAXBI Card Cage Assembly Specifications . . . . .	3-5
3-2	VAXBI Card Cage Cables . . . . .	3-5
3-3	VAXBI Subassemblies and Tools Required . . . . .	3-7
3-4	VAXBI Torque Values . . . . .	3-7
3-5	VAXBI Troubleshooting Checklist . . . . .	3-22



3-6	VAXBI Connector Cleaning Supplies . . . . .	3-23
4-1	System Control Assembly Specifications . . . . .	4-3
4-2	XTC Power Sequencer Specifications . . . . .	4-9
4-3	Control Panel Assembly Specifications . . . . .	4-13
4-4	Filter Board Specifications . . . . .	4-17
4-5	TOY Clock Battery Specifications . . . . .	4-17
4-6	TK Tape Drive Assembly Specifications . . . . .	4-21
5-1	XMI Side—DC Output Specifications . . . . .	5-5
5-2	VAXBI Side—DC Output Specifications . . . . .	5-5
5-3	AC Output Specifications . . . . .	5-5
5-4	Power Modules . . . . .	5-7
5-5	H7214 Power Regulator Specifications . . . . .	5-9
5-6	H7215 Power Regulator Specifications . . . . .	5-13
5-7	H7242 Power Regulator Specifications . . . . .	5-17
5-8	H7206-B Power and Logic Unit Specifications . . . . .	5-21
5-9	H7206-B LEDs . . . . .	5-23
5-10	H405 AC Power Controller Specifications . . . . .	5-29
5-11	50 Hz Transformer Specifications . . . . .	5-33
5-12	H7236-A Battery Backup Unit Specifications . . . . .	5-37
6-1	Front Cabinet Door and Air Filter Specifications . . . . .	6-3
6-2	Rear Cabinet Door and Air Filter Specifications . . . . .	6-5
6-3	Airflow Sensor Specifications . . . . .	6-6
6-4	Temperature Sensor Specifications . . . . .	6-9
6-5	Blower Assembly Specifications . . . . .	6-11
6-6	Side Panel Specifications . . . . .	6-17
A-1	Cable List . . . . .	A-1
D-1	VAX 6000 Platform Differences . . . . .	D-1

# Preface

---

## Intended Audience

This manual is written for Digital customer service engineers servicing <REFERENCE>(VAX\_XXXX) series systems.

## Hardware Described

This manual describes removal and replacement of field-replaceable units (FRUs) in the H9657-CA/CB/CU cabinet, one of two VAX 6000 platforms. If you are not sure which platform you are servicing, see Appendix D in this manual. If you need service information for the other platform, see *VAX 6000-400 Options and Maintenance* or *VAX 6200/6300 Options and Maintenance*.

## Document Structure

The manuals in the <REFERENCE>(VAX\_XXXX) documentation set are designed using structured documentation theory. Each topic has a boldface indented abstract, to help you use the manual as a reference tool. Other typical components of a topic include an illustration or example, a chart or list, and descriptive text.

This manual has six chapters and four appendixes:

- **Chapter 1, Introduction**, gives an overview of the <REFERENCE>(6000) platform, including specifications, field-replaceable units, and location of major assemblies.
- **Chapter 2, <REFERENCE>(XMI) Card Cage**, and **Chapter 3, VAXBI Card Cage**, describe the system card cage and the optional I/O card cage, respectively, and their removal and replacement procedures.
- **Chapter 4, System Control Assembly**, presents the subassemblies housed in the system control assembly area and gives the removal and replacement instructions for each.

- **Chapter 5, Power Subsystem**, discusses each field-replaceable unit of the power system, its diagnostics, and the removal and replacement procedure for the unit.
- **Chapter 6, Cabinet and Airflow Subsystem**, presents the field-replaceable units that are specific to the cabinet and their removal and replacement instructions.
- **Appendix A, Cable List**, lists the cables used in this platform.
- **Appendix B, XMI Backplane Connectors**, shows the location and pin numbering of XMI backplane connectors.
- **Appendix C, Module Handling**, details handling requirements for scalar and vector processor modules.
- **Appendix D, VAX 6000 Platforms**, lists the differences between the two VAX 6000 platforms.

## Conventions Used in This Document

The icons shown below are used in illustrations for designating part placement in <REFERENCE>(vax\_xxXX) series systems. A shaded area in the icon shows the location of the component or part being discussed.

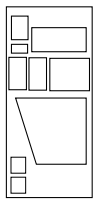

FRONT

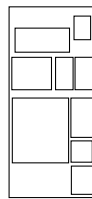

REAR

## <REFERENCE>(XXX) Documents

There are two sets of documentation: manuals that apply to all VAX 6000 series systems and manuals that are specific to one VAX 6000 model. Table 1 lists the manuals in the VAX 6000 series documentation set.

**Table 1: VAX 6000 Series Documentation**

<b>Title</b>	<b>Order Number</b>
<b>Operation</b>	
<REFERENCE>(XXX) <i>Owner's Manual</i>	EK-600EA-OM
<REFERENCE>(XXX) <i>Vector Processor Owner's Manual</i>	EK-60VAA-OM
<REFERENCE>(v6) <i>Vector Processor Programmer's Guide</i>	EK-60VAA-PG
<b>Service and Installation</b>	
<REFERENCE>(v6) <i>Platform Technical User's Guide</i>	EK-600EA-TM
<REFERENCE>(XXX) <i>Installation Guide</i>	EK-600EA-IN
<REFERENCE>(v6) <i>Installationsanleitung</i>	EK-600GA-IN
<REFERENCE>(v6) <i>Guide d'installation</i>	EK-600FA-IN
<REFERENCE>(v6) <i>Guia de instalacion</i>	EK-600SA-IN
<REFERENCE>(v6) <i>Platform Service Manual</i>	EK-600EA-MG
<b>Options and Upgrades</b>	
<i>VAX 6000: XMI Conversion Manual</i>	EK-650EA-UP
<i>VAX 6000: Installing MS65A Memories</i>	EK-MS65A-UP
<i>VAX 6000: Installing the H7236-A Battery Backup Option</i>	EK-60BBA-IN
<i>VAX 6000: Installing the FV64A Vector Option</i>	EK-60VEA-IN
<i>VAX 6000: Installing the VAXBI Option</i>	EK-60BIA-IN

Manuals specific to models are listed in Table 2.

**Table 2: VAX 6000 Model Level Documentation**

<b>Title</b>	<b>Order Number</b>
<b>Models 200/300/400</b>	
<i>VAX 6000 Model 300 and 400 Service Manual</i>	EK-624EA-MG
<i>VAX 6000: Installing Model 200/300/400 Processors</i>	EK-6234A-UP
<b>Model 500</b>	
<i>&lt;REFERENCE&gt;(MX) Mini-Reference</i>	EK-650EA-HR
<i>&lt;REFERENCE&gt;(MX) Service Manual</i>	EK-650EA-MG
<i>&lt;REFERENCE&gt;(MX) System Technical User's Guide</i>	EK-650EA-TM
<i>VAX 6000: Installing Model 500 Processors</i>	EK-KA65A-UP

## Associated Documents

Table 3 lists other documents that you may find useful.

**Table 3: Associated Documents**

<b>Title</b>	<b>Order Number</b>
<b>System Hardware Options</b>	
<i>VAXBI Expander Cabinet Installation Guide</i>	EK-VBIEA-IN
<i>VAXBI Options Handbook</i>	EB-32255-46
<b>System I/O Options</b>	
<i>CIBCA User Guide</i>	EK-CIBCA-UG
<i>CIXCD Interface User Guide</i>	EK-CIXCD-UG
<i>DEC LANcontroller 200 Installation Guide</i>	EK-DEBNI-IN
<i>DEC LANcontroller 400 Installation Guide</i>	EK-DEMNA-IN
<i>InfoServer 100 Installation and Owners Guide</i>	EK-DIS1K-IN
<i>KDB50 Disk Controller User's Guide</i>	EK-KDB50-UG

**Table 3 (Cont.): Associated Documents**

<b>Title</b>	<b>Order Number</b>
<b>System I/O Options</b>	
<i>KDM70 Controller User Guide</i>	EK-KDM70-UG
<i>RRD40 Disc Drive Owner's Manual</i>	EK-RRD40-OM
<i>RA90/RA92 Disk Drive User Guide</i>	EK-ORA90-UG
<i>SA70 Enclosure User Guide</i>	EK-SA70E-UG
<b>Operating System Manuals</b>	
<i>Guide to Maintaining a VMS System</i>	AA-LA34A-TE
<i>Guide to Setting Up a VMS System</i>	AA-LA25A-TE
<i>Introduction to VMS System Management</i>	AA-LA24A-TE
<i>ULTRIX-32 Guide to System Exercisers</i>	AA-KS95B-TE
<i>VMS Upgrade and Installation Supplement: VAX 6000 Series</i>	AA-LB36C-TE
<i>VMS Networking Manual</i>	AA-LA48A-TE
<i>VMS System Manager's Manual</i>	AA-LA00A-TE
<i>VMS VAXcluster Manual</i>	AA-LA27B-TE
<b>Peripherals</b>	
<i>HSC Installation Manual</i>	EK-HSCMN-IN
<i>H4000 DIGITAL Ethernet Transceiver Installation Manual</i>	EK-H4000-IN
<i>Installing and Using the VT320 Video Terminal</i>	EK-VT320-UG
<i>RV20 Optical Disk Owner's Manual</i>	EK-ORV20-OM
<i>SC008 Star Coupler User's Guide</i>	EK-SC008-UG
<i>TA78 Magnetic Tape Drive User's Guide</i>	EK-OTA78-UG
<i>TA90 Magnetic Tape Subsystem Owner's Manual</i>	EK-OTA90-OM
<i>TK70 Streaming Tape Drive Owner's Manual</i>	EK-OTK70-OM
<i>TU81/TA81 and TU/81 PLUS Subsystem User's Guide</i>	EK-TUA81-UG

**Table 3 (Cont.): Associated Documents**

<b>Title</b>	<b>Order Number</b>
<b>VAX Manuals</b>	
<i>VAX Architecture Reference Manual</i>	EY-3459E-DP
<i>VAX Systems Hardware Handbook — VAXBI Systems</i>	EB-31692-46
<i>VAX Vector Processing Handbook</i>	EC-H0739-46

# Chapter 1

## Introduction

---

This chapter introduces the <REFERENCE>(VAX\_XXXX) series platform (H9657 cabinet), its specifications, the location of components in the cabinet, and the field-replaceable unit list. Sections include:

- System Physical Description
- System Front View
- System Rear View
- Field-Replaceable Units



## 1.1 System Physical Description

A sample <REFERENCE>(VAX\_XXXX) system has a main cabinet, a console terminal and printer, storage cabinets, an accessories kit, and a set of documentation.

Figure 1-1: Sample <REFERENCE>(VAX\_XXXX) System

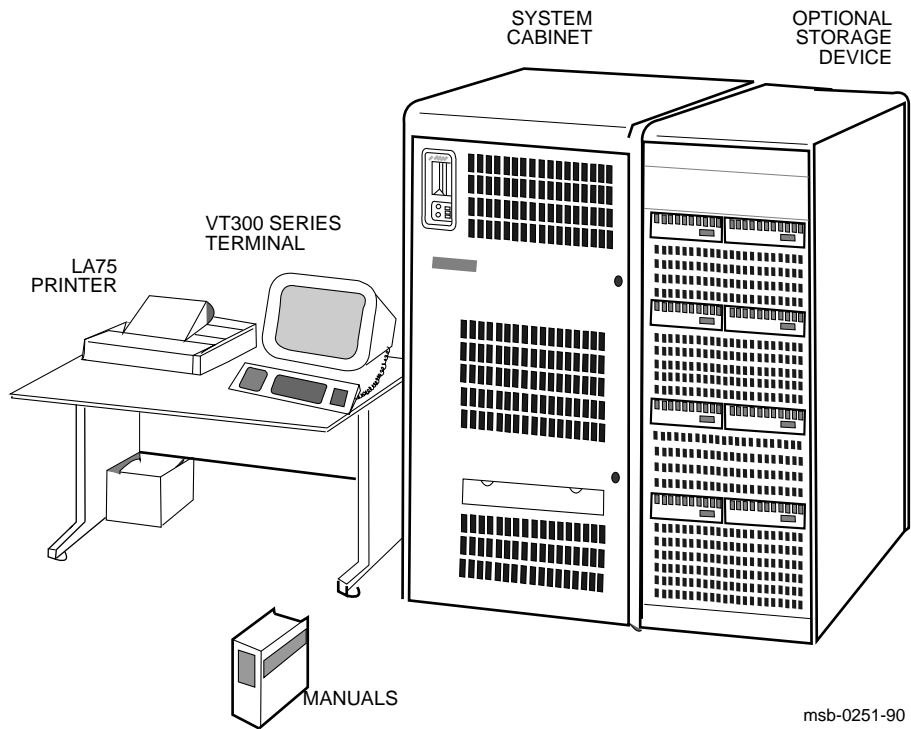

msb-0251-90

Figure 1-1 shows a sample system.

- **The main cabinet** houses the XMI card cage (which contains the processors, memories, and I/O adapters), the control panel switches, status indicators, and restart controls. It may also house any of these optional components: 12-slot VAXBI channel, console load device, battery backup unit, and disks.
- **The storage cabinet** has local storage and archiving capability.
- **The console terminal and printer** are used for console and system management operations.
- **<REFERENCE>(VAX\_XXXX) documentation** that ships with the system includes:
  - *<REFERENCE>(VAX\_XXXX) Series Installation Guide*
  - *<REFERENCE>(VAX\_XXXX) Series Owner's Manual*
  - *<REFERENCE>(VAX\_XXXX) Model 500 Mini-Reference (Model 500 systems only)*

See the Preface for a complete list of system documentation and associated documents.

**Table 1-1: <REFERENCE>(VAX\_XXXX) Series System Characteristics**

<b>Physical</b>		<b>cm (in)</b>
	Height	154 (60.5)
	Width	78 (30.5)
	Depth	76 (30.0)
	Weight	341 kg (750 lbs)
<hr/>		
<b>Environmental</b>		
Heat dissipation (max)		5440 Btu/hr (5712 KJ/hr)
Operating temperature		10° to 40°C (50° to 104°F)
Operating humidity		10% to 90% relative humidity
Altitude	Nonoperational	0 to 9.1 km (8000 to 30,000 ft)
	Operating	0 to 2.4 km (0 to 8000 ft)
<hr/>		
<b>Cooling System</b>		
	Type	Pressurized, with air moving device
	Air mover	Dual backward curved blowers
	Air source	Filtered ambient air

**Table 1–1 (Cont.): <REFERENCE>(VAX\_XXXX) Series System Characteristics**

**Electrical**

AC power consumption (max)		1.4 kW <sup>1</sup>
AC current (max)	60 Hz	8 A (208 V)
	50 Hz	4 A (416 V), 4.5 A (380 V)
Voltage input	60 Hz	3-phase 208 V RMS
	50 Hz	3-phase 380/416 V RMS
Frequency tolerance		47–63 Hz
Surge current		60 A

<sup>1</sup>Not including single-phase power to disks or battery backup unit.

## 1.2 System Front View

The control panel and optional console load device are on the front of the system cabinet, accessible with the doors closed. With the front door open, customer service engineers can access the power regulators, <REFERENCE>(XMI) card cage, the cooling system, and, if present, the VAXBI card cages, battery backup unit, and disks.

Figure 1-2: System Front View

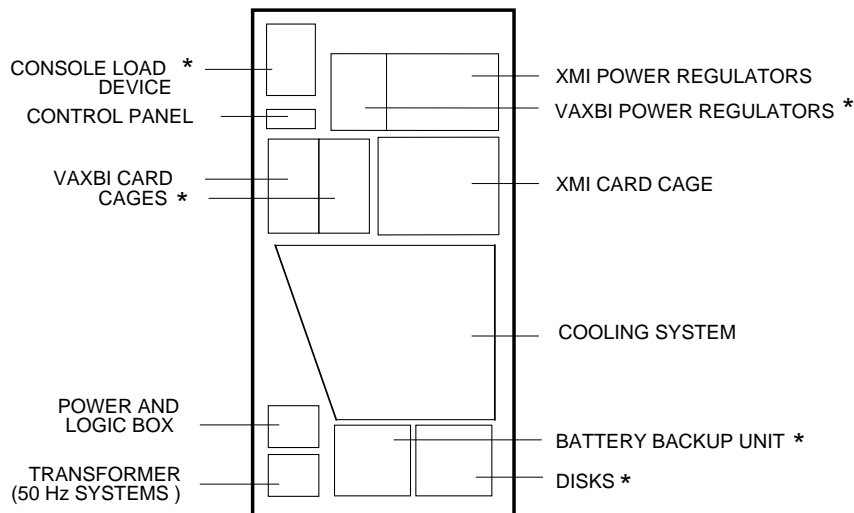

\* OPTIONAL

msb-0311-90

These components are visible from the inside front of the cabinet (see Figure 1-2 for their location):

- Control panel
- XMI power regulators
- <REFERENCE>(XMI) card cage
- Cooling system  
One of the two blowers is visible from the front of the cabinet.
- Power and logic unit
- Transformer (on 50 Hz systems only)
- Optional components:
  - Console load device
  - VAXBI power regulators
  - Two VAXBI card cages configured as one 12-slot channel
  - Battery backup unit
  - Disks

## 1.3 System Rear View

**With the rear door open, customer service engineers can access the power sequencer module (XTC); the power regulators; the I/O bulkhead space behind the card cages; Ethernet and console terminal connectors; cooling system; power and logic box; battery backup unit and disks, if present; and the AC power controller.**

**Figure 1-3: System Rear View**

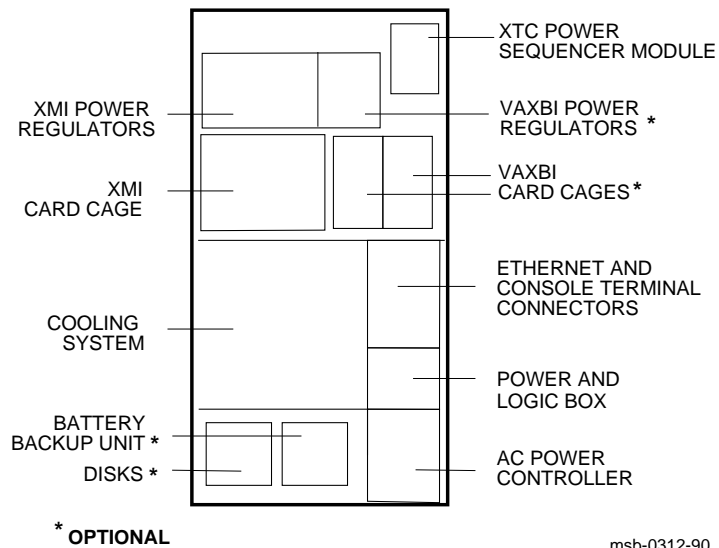

These components are visible from the rear of the cabinet (see Figure 1–3):

- Power sequencer module (XTC) located on the back of the system control assembly
- XMI power regulators
- I/O bulkhead space  
The panel covering the <REFERENCE>(XMI) and VAXBI areas is the I/O bulkhead panel and provides space for additional I/O connections.
- XMI backplane and cables
- Ethernet and console terminal connectors
- Cooling system, with open grid over a blower
- Power and logic unit
- AC power controller
- Optional components:
  - VAXBI power regulators
  - VAXBI backplane and cables
  - Battery backup unit
  - Disks



## 1.4 Field-Replaceable Units

**Table 1-2 lists the major recommended spares and their part numbers for a <REFERENCE>(VAX\_XXXX) series system.**

**Table 1-2: Field-Replaceable Units**

	<b>Part Number</b>	<b>Recommended Spare</b>	<b>Description</b>
<b>Processors:</b>	<REFERENCE>(Txxxx)		CPU module (<REFERENCE>(XmP))
	T2015	Y	CPU module (KA64A)
	T2011-YA	Y	CPU module (KA62B)
	T2017	Y	Vector module (FV64A)
<b>Adapters:</b>	T1043	Y	VAXBI adapter (DWMBB/B)
	T2018	Y	VAXBI adapter (DWMBB/A)
<b>Memory:</b>	T2014-B <sup>1</sup>	Y	32-Mbyte memory (MS62A)
	T2053-BA	Y	32-Mbyte memory (MS65A-BA)
	T2053-CA	Y	64-Mbyte memory (MS65A-CA)
	T2053-DA	Y	128-Mbyte memory (MS65A-DA)
<b>VAXBI Card Cage:</b>	H9400-AA	N	VAXBI card cage
<b>&lt;REFERENCE&gt;(XMI) Card Cage:</b>	70-24902-02	N	XMI 14-slot card cage
	54-18172-01	Y	XMI daughter card
<b>System Control Assembly:</b>	54-16574-01	Y	Control panel assembly
	20-29176-02	Y	XTC power sequencer
	TK70	Y	Tape drive
	12-19245-02	N	TOY clock battery
	20-28997-01	N	TK50/TK70 filter board
<b>Power Supply:</b>	H7214	Y	Regulator (+5V, +13.5V)

<sup>1</sup>Not supported in Model 500 systems.

**Table 1–2 (Cont.): Field-Replaceable Units**

	<b>Part Number</b>	<b>Recom- mended Spare</b>	<b>Description</b>
	H7215	Y	Regulator (+12V, -12V, -5V, -2V)
	H7242	Y	Regulator (+3.3V, +13.5V)
	H7206-B	Y	Power and logic box
	H405-E	N	60 Hz AC power controller
	H405-F	N	50 Hz AC power controller
<b>Battery Backup:</b>	29-28263-01	N	Fan
	29-28262-01	N	Battery pack
	29-28264-01	N	Enclosure
<b>Miscellaneous:</b>	12-11255-24	N	Air filter, front
	12-11255-17	N	Air filter, rear
	12-27848-01	N	Blower assembly
	12-24701-06	N	H7206-B fan
	17-01844-01	Y	Temperature sensor
	12-25024-11	N	Airflow sensor
	16-28393-01	N	Transformer (50 Hz only)
	17-02522-01	N	H7242 inhibit cable

## Chapter 2

# XMI Card Cage

---

This chapter describes the XMI card cage. Removal and replacement procedures are detailed, and configuration restrictions are listed. Sections include:

- XMI Card Cage Description
  - System Use
  - Specifications
- Removing the XMI Card Cage
- Replacing the XMI Card Cage
- Configuring Modules in Model 300 and 400 Systems
- Configuring Modules in Model 500 Systems
- XMI Troubleshooting

# 2.1 XMI Card Cage Description

## 2.1.1 System Use

The XMI card cage provides the high-speed system bus. Figure 2-1 is a simplified block diagram showing physical connections between the XMI card cage and other components in the cabinet.

Figure 2-1: XMI Card Cage Connections

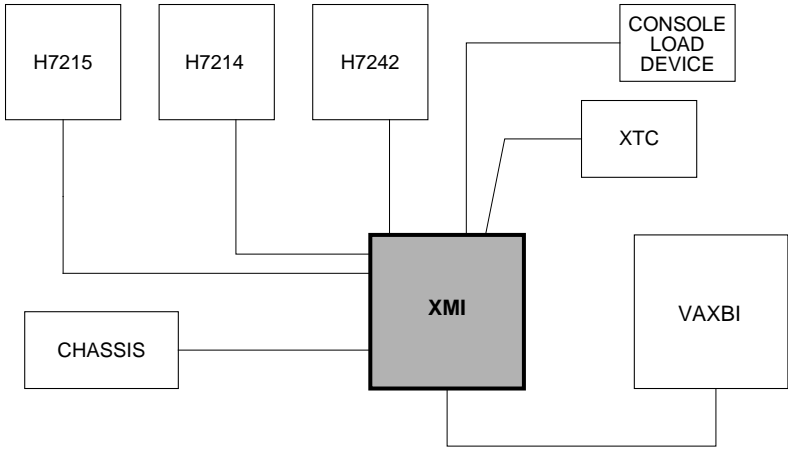

msb-0100A-90

The XMI card cage is a 14-slot cage with zero insertion force (ZIF) connectors. The cage is 3 inches deeper than a VAXBI cage, providing for larger XMI modules. The backplane area extends over three of the five connector segments, which leaves two segments for I/O pins. Mounted in the center rear of the XMI backplane is a daughter card that holds the central arbiter chip. Four slots in the center of the cage have no I/O connectors, so XMI I/O adapters cannot be installed in these slots.

For each optional VAXBI channel, there must be an XMI-to-VAXBI adapter. This adapter (DWMBB) consists of two modules: a DWMBB/A module in the XMI card cage and a DWMBB/B module in the VAXBI card cage. The configuration rules are listed in the DWMBB chapter of the *VAX 6000 Model 300 and 400 Service Manual* and the *VAX 6000 Model 500 Service Manual*. See the appropriate manual for the system you are servicing.

## 2.1.2 XMI Card Cage Specifications

The XMI card cage has 14 slots and is located in the upper part of the cabinet. The field-replaceable unit (70-24902-02) does not include the daughter card.

Figure 2-2: XMI Card Cage

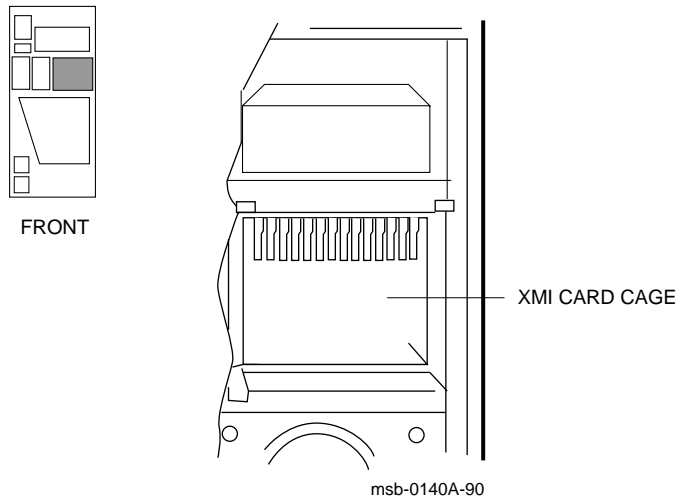

Table 2-1: XMI Card Cage Assembly Specifications

Parameter	Description
<b>Part Number:</b>	70-24902-02, 14-slot cage with no daughter card
<b>Location:</b>	Upper right front
<b>Dimensions:</b>	12" H x 10 1/2" W x 12 1/4" L
<b>Weight:</b>	29 lbs
<b>Power:</b>	H7214, H7215, and H7242 DC regulators
<b>Service From:</b>	Front and rear of cabinet

**Table 2–2: XMI Card Cage Cables and Parts**

<b>Item</b>	<b>Part Number</b>	<b>Description</b>
<b>Cables:</b>	17-01525-01	XMI to H7214 and H7242
	17-01566-01	XMI to J3 of H7215
	17-01568-02	XMI to J4 of XTC, 20-pin ribbon
	17-01662-01	XMI ground strap
	17-02759-01	Fail safe enable cable, XMI to H7236-A battery backup unit and H405
	17-01375-04	15' DWMBB cables for expander cabinet, from XMI slots 1, 2, 3, and 4 as needed (segments D and E) to VAXBI cages 2, 3, 4, and 5 slot 1 (segments D and E). Two per DWMBB.
	17-01897-02	7" DWMBB cables, from XMI slot E (segments D and E) to VAXBI cage 1 slot 1 (segments D and E). Two per DWMBB.
	17-02521-01	Fail safe enable cable
	17-02522-01	H7242 inhibit (Model 300 and 400 systems only)
<b>Tools Required:</b>		
<b>VAXBI Tool Kit</b>	A2-M1094-10	Includes: Torque screwdriver Large Phillips and flat screwdrivers Small Phillips screw-holding screwdriver or one with magnetic tip 11/32" nutdriver 1/4" nutdriver
<b>Subassemblies:</b>		
<b>Daughter Card</b>	54-18172-01	Clock/arbitrator module, mounts on XMI backplane
<b>Foam Air Seals</b>	74-34536-01 74-34536-03 74-36670-02	Three pieces of foam used for air seals

## 2.2 Removing the XMI Card Cage

The XMI card cage is removed from the front of the cabinet after you disconnect cables from the backplane.

### 2.2.1 Prepare for Removal

Prepare the system for shutdown. Set up a work space nearby where you can store the modules and work on the XMI card cage. Label and disconnect the signal and power connections.

Figure 2-3: XMI Backplane Cables and Power Connections

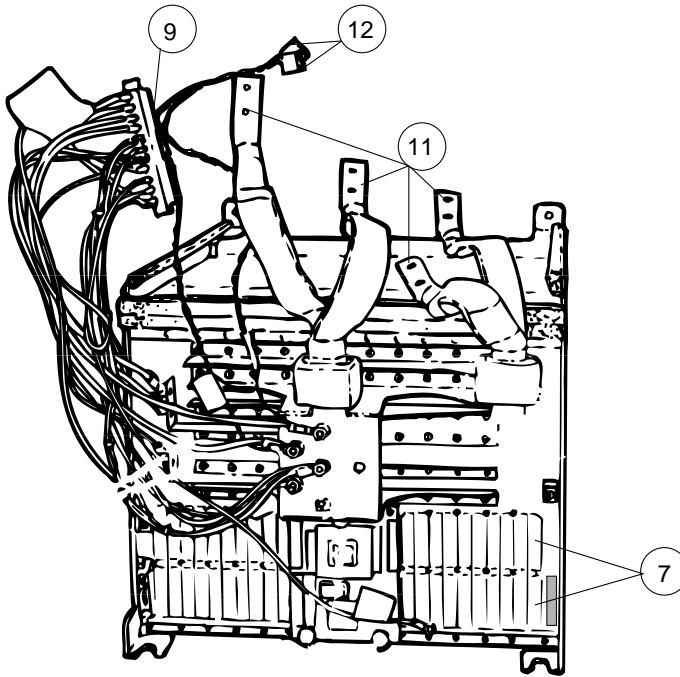

msb-0703A-90



1. Perform an orderly shutdown of the system.
2. Turn the upper key switch on the front control panel to the Off position.
3. Pull the circuit breaker on the AC power controller to the Off position. The AC power controller is at the bottom rear of the cabinet.
4. Unplug the system.
5. Open the rear cabinet door.
6. Remove the screws and drop the I/O bulkhead tray to expose the card cages.

**CAUTION:** *You must wear an antistatic wrist strap attached to the cabinet when you handle any modules.*

**NOTE:** *Figure 2-3 shows the end to disconnect for each of the following cables.*

7. Disconnect all I/O adapter cables from the XMI card cage. See ⑦ in Figure 2-3.
8. Loosen the 5/16 inch nut on the H7215 cable retainer bracket. Swing the bracket to one side.
9. Disconnect the power supply cable (17-01566-01) from J3 of the H7215 power regulator. See ⑨.
10. If present, remove the plastic covers over the power harnesses. To do this, remove the three 5/16 inch nuts that connect each cover to the back of a regulator.
11. Disconnect the power connections from the H7214 and H7242 power regulators. (On each regulator, remove the four screws from the leads.) See ⑩.
12. Disconnect the remote sense wires from the H7214 and H7242 regulators (17-01525-01). (Remove connector J4 from the regulator.) See ⑫.

**Figure 2-4: Control/Status Cable**

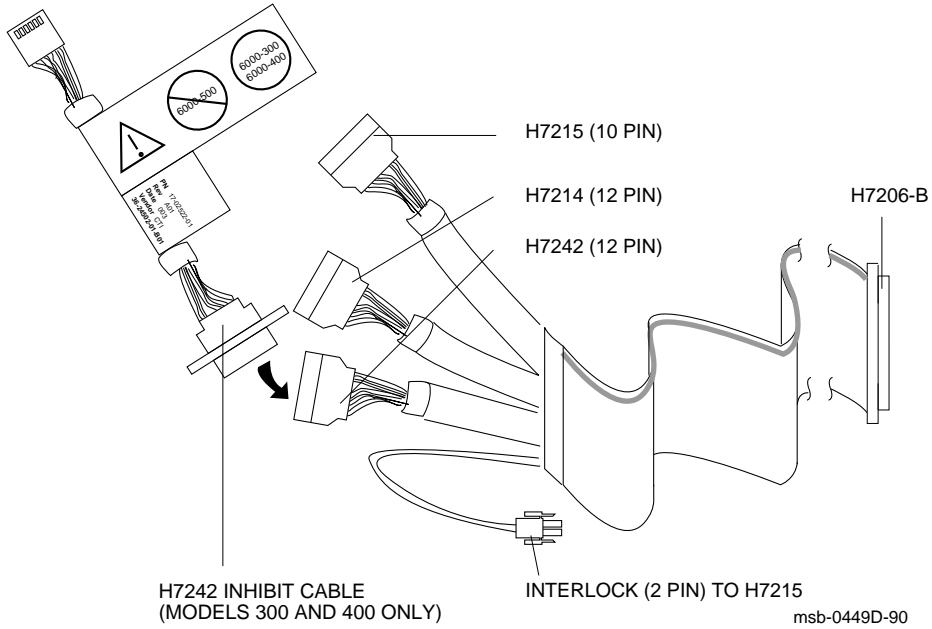

13. If this is a Model 300 or 400, remove the H7242 inhibit cable (17-02522-01). See Figure 2-4.
14. Disconnect the cable (17-01568-02) to the XTC power sequencer from J1 at the lower left corner of the card cage. See 14 in Figure 2-5.
15. Disconnect four wires from the bus bars that go to the system control assembly: +5V (red); +12V (orange); and two ground connections (brown and black). Use an 11/32 inch nutdriver. See 15.
16. Disconnect the ground strap (17-01662-01) from the chassis. Remove the screw from the bus bar with a large Phillips screwdriver. See 16.
17. Disconnect the red and black leads from the 17-02521-01 cable. See 17.
18. Disconnect the power supply enable cable (17-02500-01) from J8 at the lower right corner of the card cage. See 18.
19. Disconnect the control/status cable from the regulators at the interlock (H7215) and J2 (H7215), J1 (H7214), and J1 (H7242). See Figure 2-4.

**Figure 2-5: XMI Backplane Diagram**

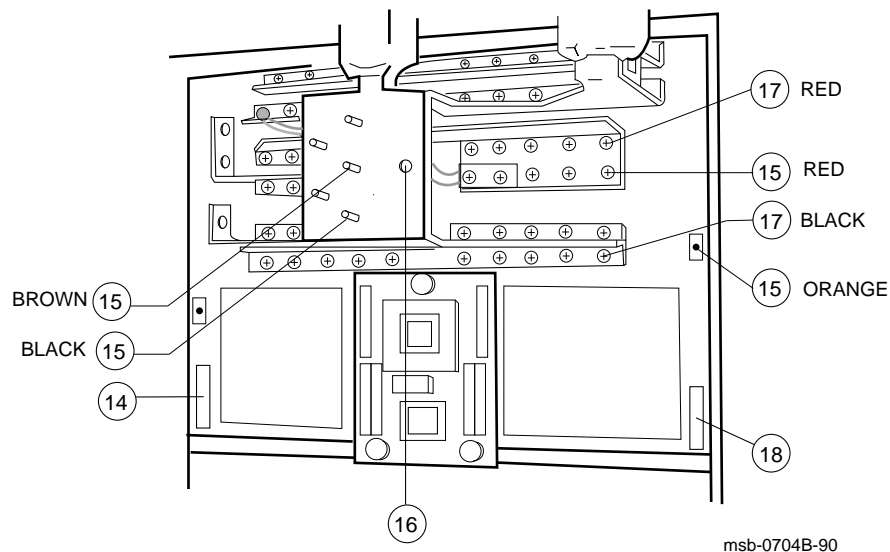

## 2.2.2 Remove the XMI Card Cage from the Cabinet

**Remove all modules from the cage and set them aside, and then remove the cage from the cabinet.**

Figure 2-6: XMI Card Cage

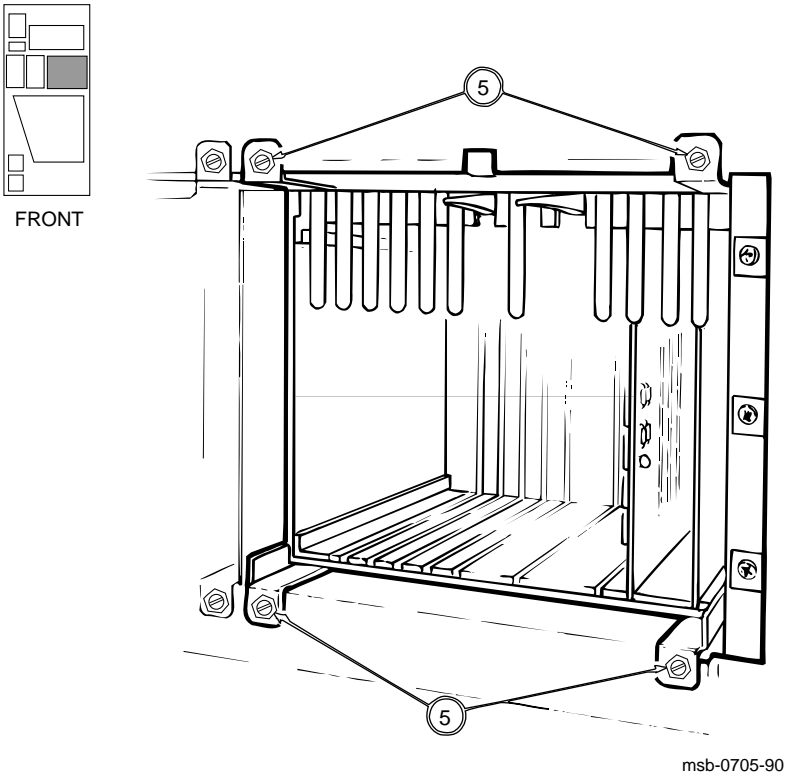

1. Open the front cabinet door.
2. Remove the clear plastic door in front of the XMI card cage.

**CAUTION:** *You must wear an antistatic wrist strap attached to the cabinet when you handle any modules. See Appendix C for processor module handling instructions.*

3. If the XMI card cage does not have a module use label, attach one below the front of the cage and fill it in. This makes returning modules to their correct slots easier after you install the new card cage.
4. Lift up the levers and hold. Remove the modules from the cage and put them in ESD boxes.
5. Using a 1/4 inch nutdriver or a large flat screwdriver, remove and save the four mounting screws (1/4 inch hex head) that fasten the XMI cage assembly to the chassis. See ⑤ in Figure 2-6.
6. Pull the cage out of the system cabinet carefully so that you do not damage the power harnesses or bus bars. Push from the back to ease the cage out toward the front of the cabinet. This step requires two persons.

### 2.2.3 Remove the Daughter Card

**The daughter card must be removed from the XMI cage. It will be installed on the new XMI cage.**

Figure 2-7: XMI Daughter Card

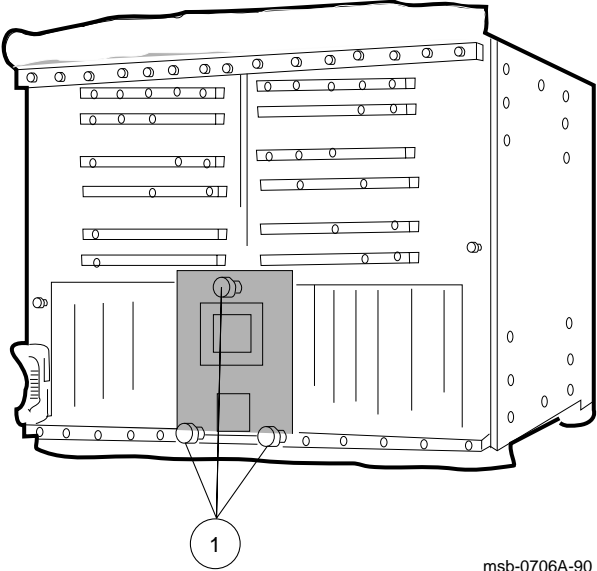

msb-0706A-90

**CAUTION:** *The daughter card is static sensitive. You must wear an antistatic wrist strap attached to the cabinet when you handle it.*

1. Unscrew and save the three large thumbscrews that hold the daughter card to the XMI backplane. See ❶ in Figure 2-7.
2. Pull the daughter card away from the backplane.
3. Set the daughter card on an antistatic mat.

## 2.3 Replacing the XMI Card Cage

**Attach the daughter card that you removed from the defective cage onto the new cage. Install the new cage in the system cabinet, attach all cables, and put the modules back into their slots.**

### 2.3.1 Attach the Daughter Card

**Install the daughter card that you removed from the defective cage.**

Figure 2-8: XMI Daughter Card

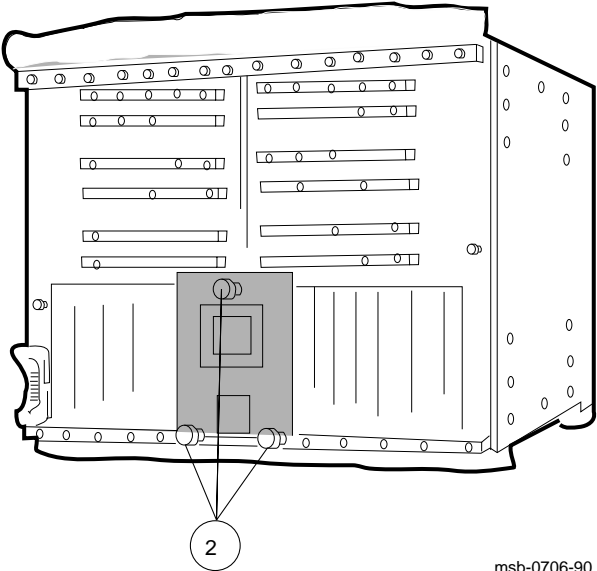

msb-0706-90



**CAUTION:** *The daughter card is static sensitive. You must wear an antistatic wrist strap attached to the cabinet when you handle it.*

1. Align the daughter card on the backplane.
2. Attach the daughter card with the three thumbscrews. See ② in Figure 2-8.

### 2.3.2 Install the Card Cage, Attach the Cables, and Insert the Modules

**Install the new XMI card cage in the system cabinet. Reattach all the connections on the backplane, install the nuts attaching the cage to the chassis, and then put the modules back into their slots.**

Figure 2-9: XMI Card Cage

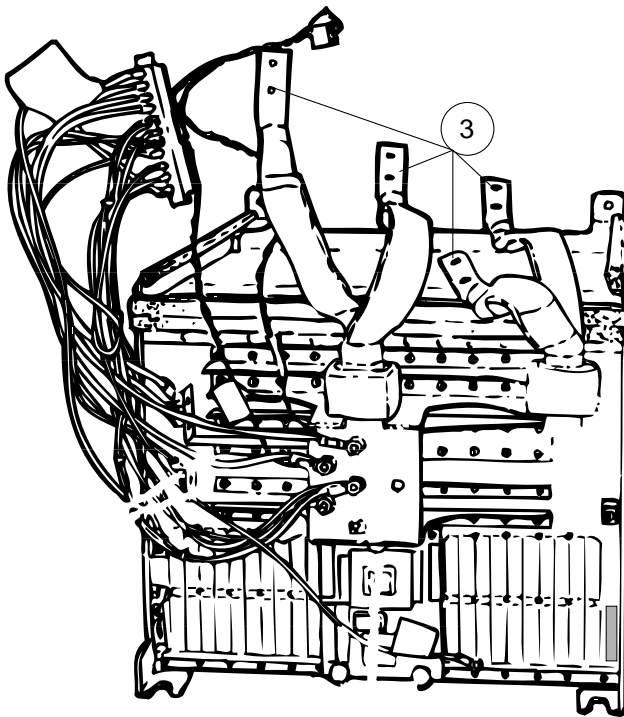

msb-0707-90

1. Bend back the power harnesses and slide the new card cage (levers up) into the cabinet. Push from the front and pull from the rear. This step requires two persons.
2. Use a nutdriver to tighten the four mounting nuts that secure the card cage assembly to the front of the cabinet. See Figure 2-6.
3. Reattach the power connections. On the H7214 and H7242 regulators, torque the screws to 27 (+/-5) inch-pounds. See ③ in Figure 2-9.

**CAUTION:** *You must use the 5/16 inch screws. If you use the longer 7/16 inch screws, the power regulators may short out.*

4. Reverse Steps 6 through 19 in Section 2.2.1.

**NOTE:** *When replacing the control/status cable, be sure the white dot on the connector is at the top.*

5. Check the module use label for correct placement and install the modules removed from the defective card cage. See Section 2.4 for Models 300 and 400 configuration rules or Section 2.5 for Model 500 configuration rules.
6. Replace the clear plastic door in front of the card cage.
7. Turn on system power and check that all nodes pass self-test.

**NOTE:** *See the Verification chapter in the VAX 6000 Series Installation Guide for complete acceptance instructions.*

## 2.4 Configuring Modules in Model 300 and 400 Systems

The XMI card cage design, XMI architecture, and processor model place some restrictions on the use of the slots. Only XMI modules may be placed in the XMI card cage; installing any other modules may destroy the modules.

Figure 2-10: Numbering of XMI Slots

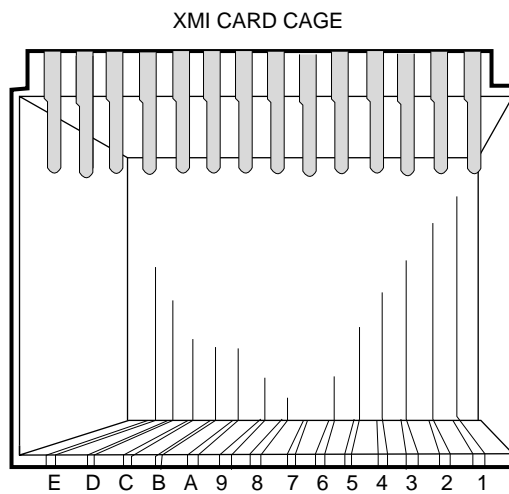

msb-0107-89

**CAUTION:** *Never attempt to insert a VAXBI module into an XMI card cage. The backplane technology for the XMI and VAXBI is similar but incompatible. Inserting a VAXBI module into an XMI card cage can destroy the module. Note that VAXBI modules are shorter than XMI modules.*

An XMI node takes its node number from the slot in which it resides. This is unlike the VAXBI bus where the node number assignment derives from node ID plugs inserted into the backplane for each slot.

Figure 2-10 shows the numbering of the slots in the XMI card cage. Slots are numbered in hexadecimal to correspond to the self-test display.

Figure 2-11 shows the maximum number of processor, memory, and I/O modules that may be installed in Model 300 and 400 systems. Slots where a module may **not** be installed are indicated by the letter N. Installation in all other slots is permitted.

**Figure 2-11: XMI Configuration Rules for Models 300 and 400**

		① SLOT													
MODULE	LIMIT	E	D	C	B	A	9	8	7	6	5	4	3	2	1
PROCESSOR	6 ②														
MEMORY	8 ③														
I/O	8 ④					N	N	N	N	N	N				

msb-0715-90

- ① Slot E must contain a module. Slot E contains a DWMBB/A module when the system has a VAXBI bus.
- ② For a Model 400 system with a vector processor, see configuration rules in *VAX 6000 Models 300 and 400 Service Manual*.
- ③ The total amount of memory is limited to 512 Mbytes.
- ④ Slots 5 through A may not contain I/O modules.

Any problems with the XMI cage or modules are indicated in the first three lines of the self-test display. The self-test display is explained in the *VAX 6000 Models 300 and 400 Service Manual*.

## 2.5 Configuring Modules in Model 500 Systems

**The XMI card cage design, XMI architecture, and processor model place some restrictions on the use of the slots. Only XMI modules may be placed in the XMI card cage; installing any other modules may destroy the modules.**

Figure 2-12: Numbering of XMI Slots

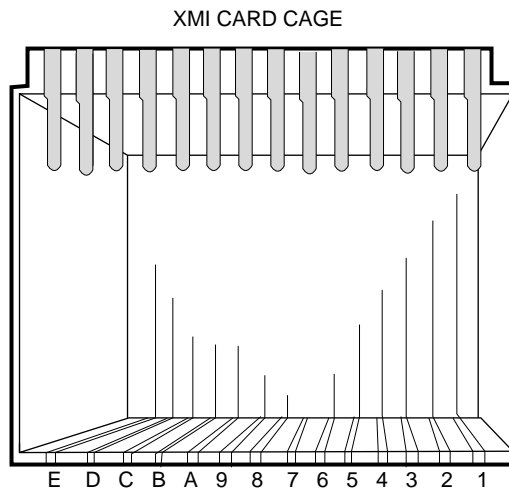

msb-0107-89

**CAUTION:** *Never attempt to insert a VAXBI module into an XMI card cage. The backplane technology for the XMI and VAXBI is similar but incompatible. Inserting a VAXBI module into an XMI card cage can destroy the module. Note that VAXBI modules are shorter than XMI modules.*

An XMI node takes its node number from the slot in which it resides. This is unlike the VAXBI bus where the node number assignment derives from node ID plugs inserted into the backplane for each slot.

Figure 2-12 shows the numbering of the slots in the XMI card cage. Slots are numbered in hexadecimal to correspond to the self-test display.

Figure 2-13 shows the maximum number of processor, memory, and I/O modules that may be installed in Model 500 systems. Slots where a module may **not** be installed are indicated by the letter N. Installation in all other slots is permitted.

**Figure 2-13: XMI Configuration Rules for Model 500**

		① SLOT													
MODULE	LIMIT	E	D	C	B	A	9	8	7	6	5	4	3	2	1
PROCESSOR	6 ②														
MEMORY	8 ③														
I/O	8 ④						N	N	N	N					

msb-0715A-90

- ① Slot E must contain a module. Slot E contains a DWMBB/A module when the system has a VAXBI bus.
- ② For a system with a vector processor, see configuration rules in *VAX 6000 Model 500 Service Manual*.
- ③ The total amount of memory is limited to 512 Mbytes. Only MS65A memory is supported.
- ④ Slots 6 through 9 may not contain I/O modules.

Any problems with the XMI cage or modules are indicated in the first three lines of the self-test display. The self-test display is explained in the *VAX 6000 Model 500 Service Manual*.

## 2.6 XMI Troubleshooting

**When you install modules in the XMI card cage, several items need to be checked. Table 2-3 gives a checklist of items to troubleshoot.**

**Table 2-3: XMI Troubleshooting Checklist**

<b>Symptom</b>	<b>Possible Cause</b>
No power to cages	Clear plastic door not in place or not latched.
Intermittent module response	Poor contact at connector
	Loose cabling at the backplane
	Power connector reattached with 7/16" screw instead of 5/16" screw
Module does not appear on self-test results	Loose cabling at the backplane
	System not configured correctly.



Clear plastic doors cover the XMI and VAXBI card cages. If these doors are opened when power is still on, a power interlock switch cuts off power from the regulators to either the VAXBI side or to the XMI side, depending on the door opened.

Before turning power back on, make sure the clear plastic doors are in place and latched.

The XMI bus requires a non-memory module in slot E. If this slot is empty, the bus will shut down.

If you receive intermittent module response, or the module does not show up on self-test as being present at all, make sure the module is seated properly, and check the backplane cabling.

Modules may fail self-test because of poor contact at the connector. A thorough cleaning of the gold pads on the module and of the connector in the card cage corrects this contact failure. If the connections seem to be faulty, clean the contact areas of the connector and module. Table 2-4 lists tools and supplies for connector cleaning.

**Table 2-4: XMI Connector Cleaning Supplies**

<b>Item</b>	<b>Part Number</b>	<b>Function</b>
VAXBI tool kit	A2-M1094-10	Maintaining card cages
Paddle wipe handle	47-00116-02	Holding paddle wipes
Paddle wipes	12-26321-01	Cleaning contact area inside ZIF connectors
Gold-wipes™	49-01603-00	Cleaning module connector contact area
Protective goggles	29-16141-10	Eye protection
Nitrile gloves	29-26403-00	Hand protection

™Gold-wipes is a trademark of TEXWIPE.

## Chapter 3

# VAXBI Card Cage

---

This chapter describes the optional VAXBI card cage and its use in the <REFERENCE>(VAX\_XXXX) system. Removal and replacement procedures are detailed, and configuration restrictions are listed. Sections include:

- VAXBI Card Cage Description
  - System Use
  - Specifications
  - Subassemblies
- Removing the VAXBI Card Cage
- Replacing the VAXBI Card Cage
- VAXBI Expansion and Configuration Rules
- VAXBI Troubleshooting

## 3.1 VAXBI Card Cage Description

### 3.1.1 System Use

The optional VAXBI card cage serves as a second I/O subsystem of a <REFERENCE>(VAX\_XXXX) system. The two VAXBI card cages provide one 12-slot VAXBI channel. The interface between the VAXBI bus and the XMI bus is the DWMBB option. The DWMBB/B module requires one slot in the VAXBI card cage.

Figure 3-1: VAXBI Card Cage Connections

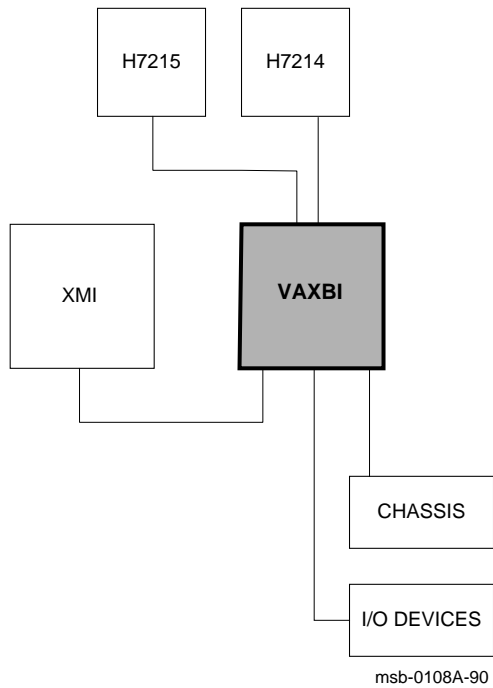

The <REFERENCE>(VAX\_XXXX) system uses the optional VAXBI bus for input/output. When used, two VAXBI card cages are installed in the processor cabinet. These two card cages provide one 12-slot VAXBI channel. A VAXBI expander cabinet can also be added, which can hold up to four VAXBI cages (four 6-slot channels).

The VAXBI card cage has zero insertion force (ZIF) connectors. The backplane area extends over two of the five connector segments; the remaining three segments are used for I/O connections. Installed on the cage are I/O transition headers.

Each VAXBI bus has its own XMI-to-VAXBI adapter (DWMBB). The DWMBB/B module of this adapter resides in the VAXBI card cage.

### 3.1.2 VAXBI Card Cage Specifications

**The VAXBI card cage is a 6-slot cage. (The two cages in the system cabinet are configured as one 12-slot VAXBI channel.) The VAXBI card cages are located in the upper part of the cabinet, on the left as you view the system from the front. The field-replaceable unit (H9400-AA) does not include the power bus bar assembly, the node ID plugs, the terminator, and the flexible backplane extension.**

Figure 3-2: VAXBI Card Cages

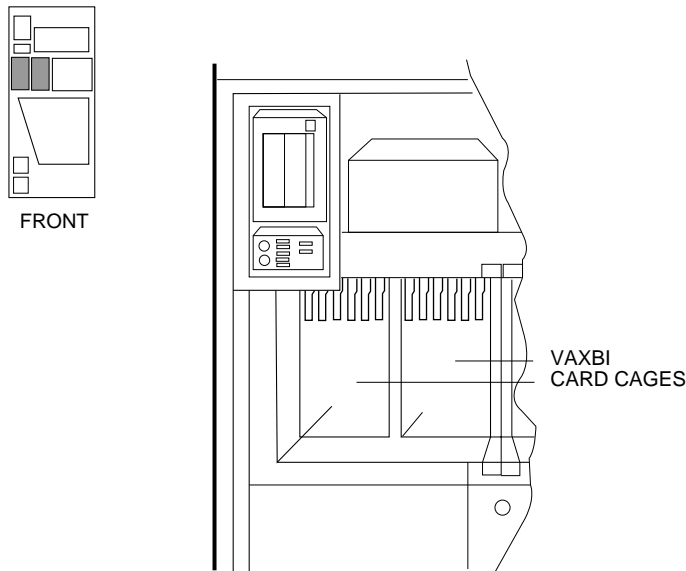

msb-0141A-90

**Table 3–1: VAXBI Card Cage Assembly Specifications**

<b>Parameter</b>	<b>Description</b>
<b>Part Number</b>	H9400-AA, one 6-slot cage with no terminators or bus bars; includes transition headers
<b>Location:</b>	Upper left front
<b>Dimensions:</b>	12.5" W x 9.5" D x 10" L
<b>Weight:</b>	26 lbs (2-cage assembly)
<b>Power:</b>	One H7215 DC regulator and one H7214 DC regulator supply power to the 2-cage assembly.
<b>Service From:</b>	Front and rear

**Table 3–2: VAXBI Card Cage Cables**

<b>Part Number</b>	<b>Description</b>
17-01038-01	Flexible backplane extension (FBE) cable connecting the two VAXBI backplanes in the system cabinet
17-01149-01	Firmware console-enable jumper (on Ethernet adapter slot, slot 6, segment E1)
17-01458-02	VAXBI ground strap
17-01496-01	Ethernet (from slot 6, segment E2, to H7214 (+13.5V) and to Ethernet port)
17-01523-01	VAXBI +/-12V to J3 on H7215
17-01569-01	DWMBB, from slot 1, segment C1, to J11 of H7206-B
17-01897-01	15' DWMBB cables for expander cabinet, from XMI slots 1, 2, 3, and 4 as needed (segments D and E) to VAXBI channels 2, 3, 4, and 5 slot 1 (segments D and E). Two per DWMBB.
17-01897-02	7" DWMBB cables, from XMI slot E (segments D and E) to VAXBI cage 2 slot 1 (segments D and E). Two per DWMBB.

### 3.1.3 VAXBI Card Cage Subassemblies

Table 3-3 lists the part numbers for FRUs of the VAXBI card cage assembly in the <REFERENCE>(VAX\_XXXX) system.

Figure 3-3: VAXBI Card Cage Subassemblies

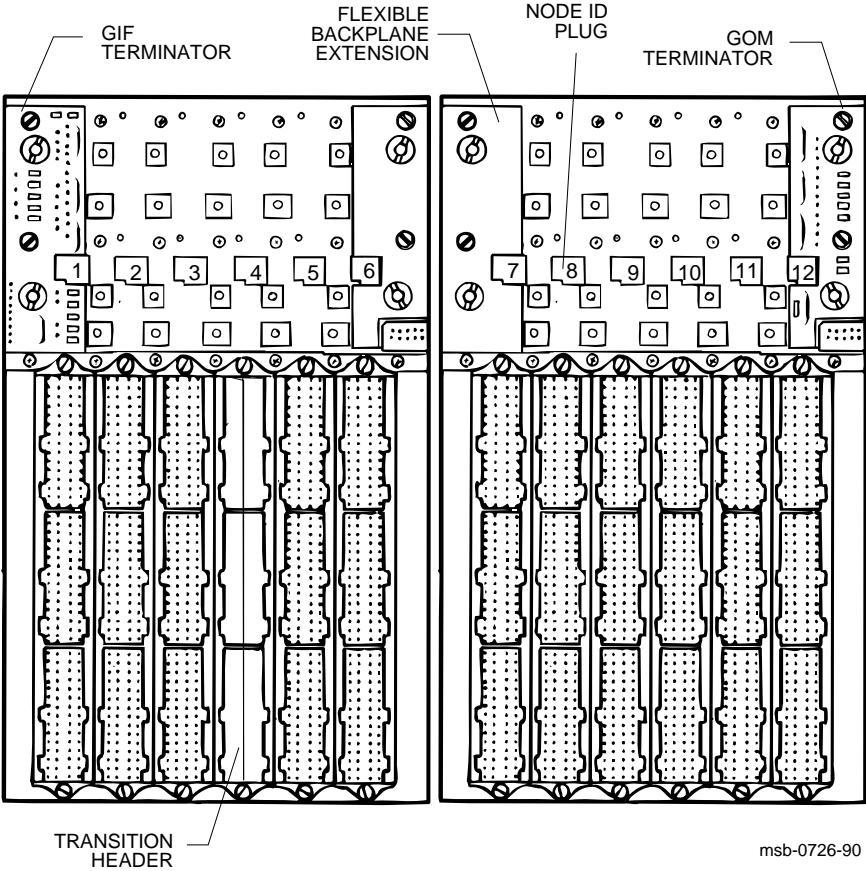

**Table 3–3: VAXBI Subassemblies and Tools Required**

<b>Item</b>	<b>Part Number</b>	<b>Description</b>
<b>Subassemblies:</b>		
<b>Bus Bar Assembly</b>	12-28508-01	+5V/Ground VAXBI bus bars
	12-28342-01	-5.2V VAXBI bus bars
	12-28345-01	-2V VAXBI bus bars
<b>Ground Bus Jumper</b>	12-28353-01	Bus bar ground strap
<b>Terminators</b>	20-24486-01	Near end (GIF)
	20-24487-01	Far end (GOM)
<b>VAXBI Node IDs</b>	12-23701-17	Set of 16
<b>Transition Header</b>	12-22246-01	Three-segment I/O header
<b>Foam Air Seals</b>	74-34536-01	Three pieces of foam used for air seals
	74-34536-02	
	74-34536-03	
<b>Flexible Backplane Extension</b>	17-01038-01	Electrically connects two VAXBI card cages to create one 12-slot channel
<b>Tools Required:</b>		
<b>VAXBI Tool Kit</b>	A2-M1094-10	Includes: Torque screwdriver Offset ratchet screwdriver Large and small Phillips screwdrivers Small Phillips screw-holding screwdriver or one with magnetic tip Flat screwdriver

**Table 3–4: VAXBI Torque Values**

<b>Item</b>	<b>Torque Value (inch-pounds)</b>
Bus bar assembly screws	9 (+/-1)
FBE jackscrews	6 (+/-1)
Transition header screws	6 (+/-1)
H7214 power regulator screws	27 (+/-5)



## 3.2 Removing the VAXBI Card Cage

The two VAXBI card cages are bolted together and must be removed as a unit. Remove them from the front of the cabinet after you disconnect cables from the backplane. Remove the system control assembly first (see Section 4.2).

### 3.2.1 Prepare for Removal

Prepare the system for shutdown. Set up a work space nearby where you can store the modules and work on the VAXBI card cages. Label and disconnect the signal and power connections.

Figure 3-4: VAXBI Backplane Cables and Power Connections

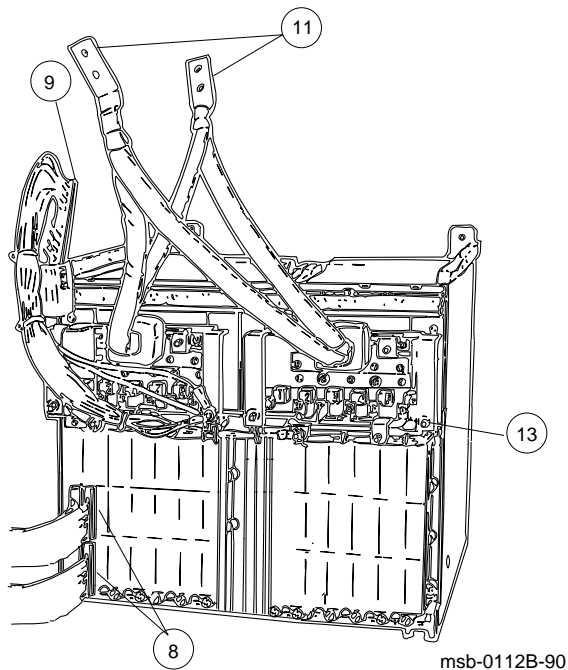

1. Perform an orderly shutdown of the system.
2. Turn the upper key switch on the front control panel to the Off position.
3. Pull the circuit breaker on the AC power controller to the Off position.
4. Unplug the system.
5. Open the front and rear doors.
6. Remove the system control assembly. See Section 4.2 for the removal procedure.
7. Remove the screws and drop the I/O bulkhead tray to expose the card cages.

**NOTE:** *Figure 3-4 shows the end to disconnect for each of the following cables.*

8. Remove and label all connectors from segments C, D, and E of the transition headers. For the CIBCA and KDB50, instead of removing cables, remove the transition headers from the card cage, since the I/O segment is a permanent part of the transition header. To do this, remove the top and bottom screws, and then remove the header. See ③ in Figure 3-4.
9. Loosen the 5/16 inch nut on the H7215 cable retainer bracket. Swing the bracket to one side. Disconnect the cable (17-01523-01) to the H7215 power regulator. (Remove connector from the regulator.) See ⑨.
10. If present, remove the plastic covers over the power harnesses. To do this, remove the three nuts (5/16 inch hex) that connect each cover to the back of a regulator.
11. Disconnect the harness to the H7214 power regulator. (On the regulator, remove the four screws that fasten the harness to the regulator.) See ⑩.
12. If the card cage has a DEBNI adapter, disconnect the Ethernet line (17-01525-01, J2) to the H7214 regulator. Remove connector J4 from the H7214 regulator. These connections are not shown on Figure 3-4.
13. Disconnect the ground strap from the cage on the right to the chassis (17-01458-02). See ⑬.

### 3.2.2 Remove the VAXBI Card Cages from the Cabinet

**Before removing the cages from the cabinet, remove all modules and set them aside.**

Figure 3-5: VAXBI Card Cages

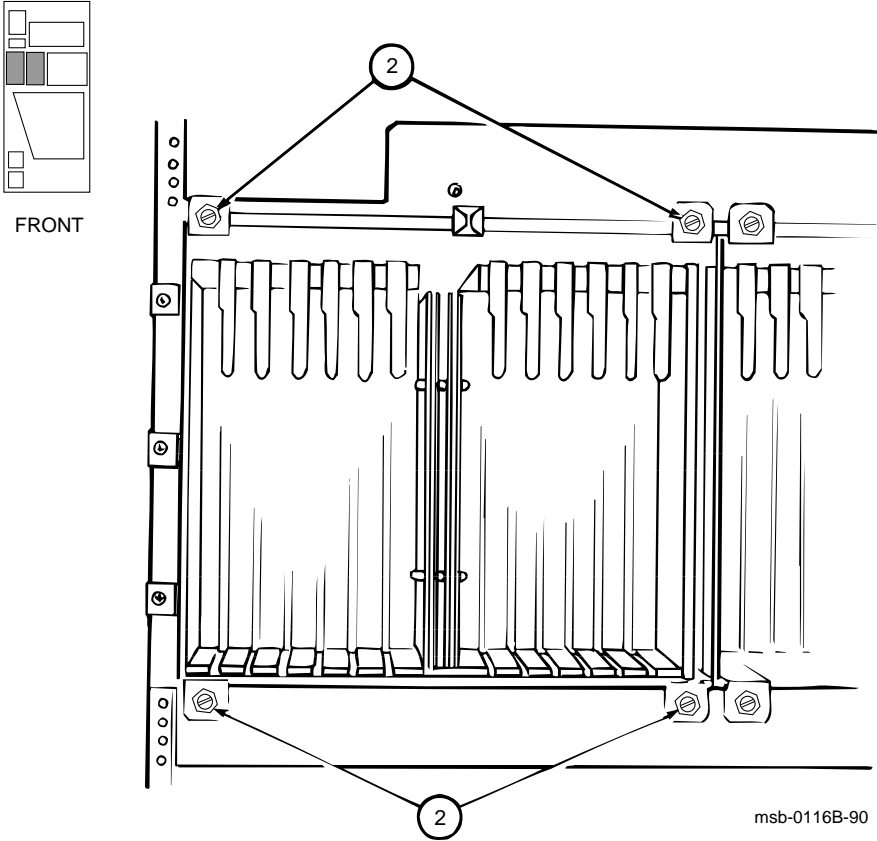

1. Remove the front cabinet door. See Section 6.1.
2. Remove the clear plastic door in front of the VAXBI card cage.

**CAUTION:** *You must wear an antistatic wrist strap attached to the cabinet when you handle any modules.*

3. If the VAXBI card cage does not have a module use label, attach one below the front of the cage and fill it in. This makes returning modules to their correct slots easier after you install the new card cage.
4. Lift up the levers to remove modules. Put them in ESD boxes and note which slots they had been in.
5. Remove and save the four mounting screws (1/4 inch slotted hex) that fasten the VAXBI assembly to the chassis. See ⑤ in Figure 3-5.
6. Pull the cages out of the system cabinet carefully so that you do not damage the power harnesses or bus bars.

### 3.2.3 Remove the VAXBI Bus Bars and FBE

**The VAXBI bus bars and one side of the flexible backplane extension (FBE) must be removed from the cage that is being replaced. Do not remove the bus bars and FBE from both cages.**

Figure 3-6: VAXBI Bus Bar Assembly

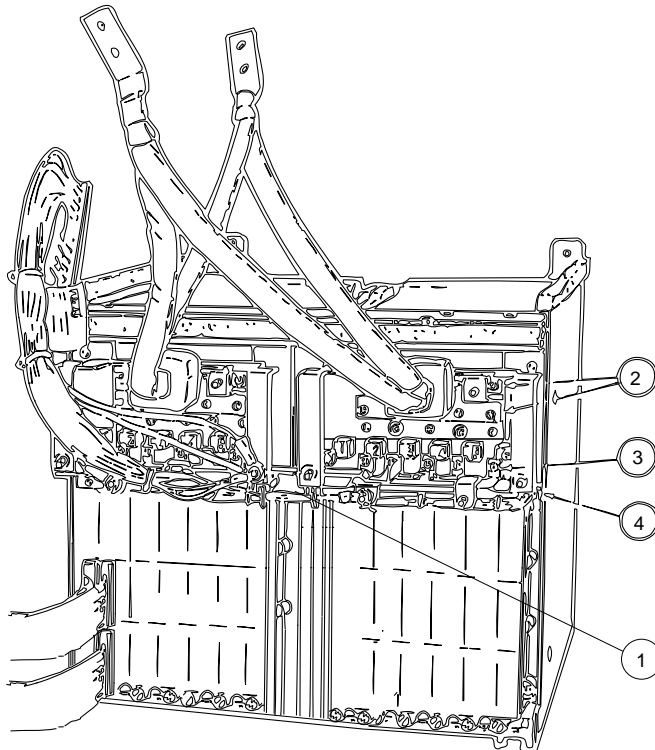

msb-0112A-90

1. Remove the ground bus jumper by removing the two nuts (11/32 inch hex). See ❶ in Figure 3-6.

On *only* the cage that needs to be replaced in the two-cage assembly, remove these parts in the following order. Use a small Phillips screwdriver (#6-32 screws).

2. Remove the +5V/Ground bus bar assembly (12-28508-01), 14 screws. See ❷.
3. Remove the -5.2V and -2V bus bars (5 screws into the power cubes). See ❸.
4. Disconnect the +/-12V connector (orange and blue wires). Disconnect from the backplane of the card cage being removed. See ❹.
5. Loosen the jackscrews and pull the FBE straight out. Leave the FBE attached to the other card cage. See Figure 3-7.

Figure 3-7: VAXBI Flexible Backplane Extension

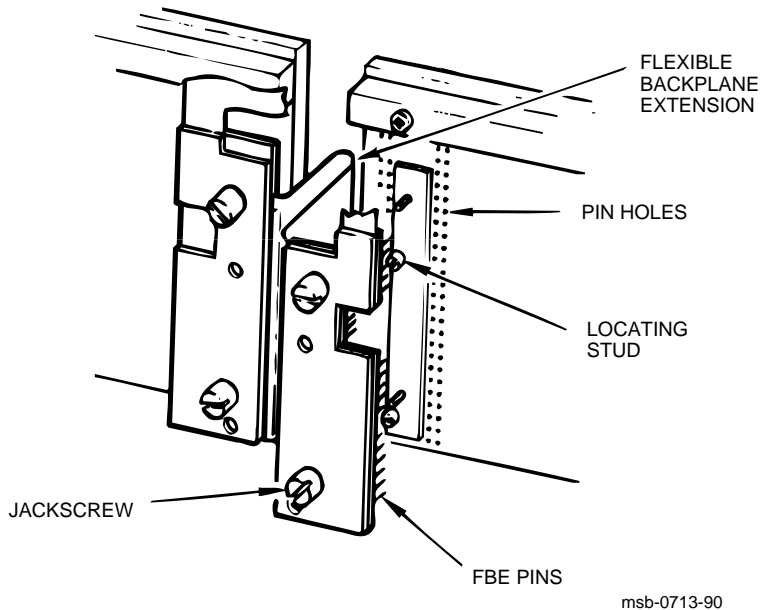

### 3.2.4 Remove Other VAXBI Parts

**Remove the node ID plugs, the terminator, and the mounting plates from the cage being replaced.**

**Figure 3-8: VAXBI Backplane Components**

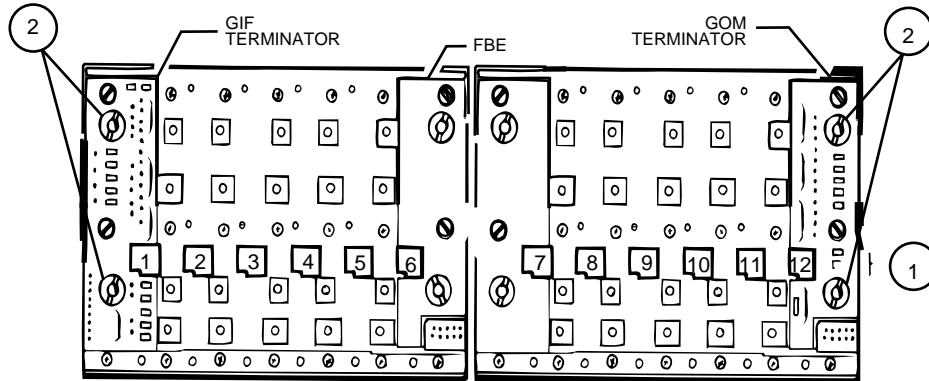

msb-0708-90

1. Remove the node ID plugs. See ❶ in Figure 3-8.
2. Remove the terminator (GOM or GIF) by removing the two slotted screws. See ❷.
3. Remove the side and inner mounting plate so that you can slide the defective cage away from the remaining cage. For the inside plate, remove the innermost screws with an offset ratchet screwdriver. See ❸ in Figure 3-9.

Figure 3-9: VAXBI Cage Mounting Plates

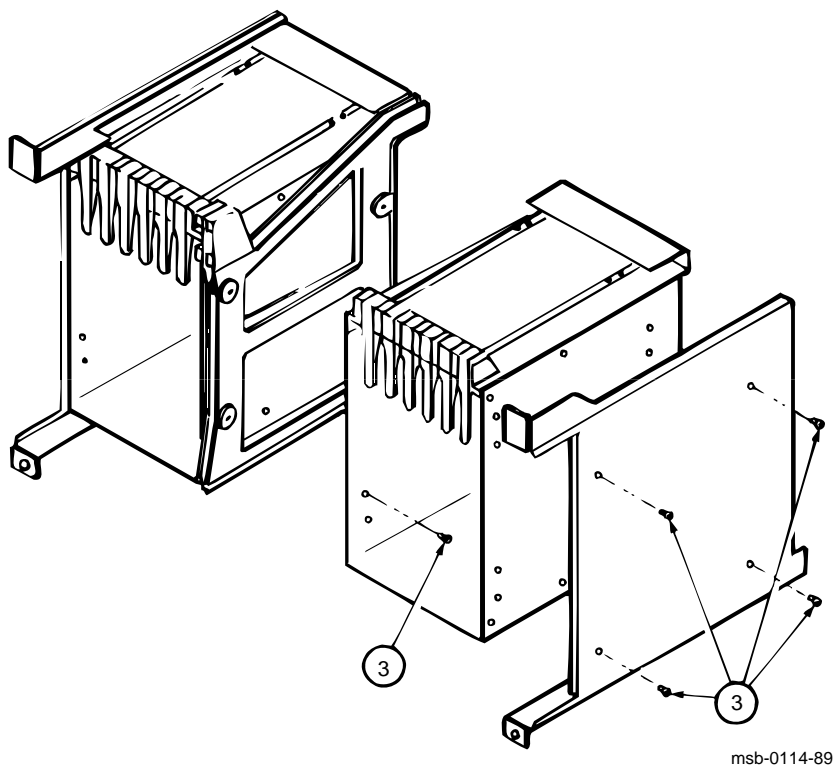



### 3.3 Replacing the VAXBI Card Cage

**Install the parts removed from the defective card cage and return the two-cage assembly to the system. Reattach all the connections on the backplane, install the screws attaching the cage to the chassis, and then put the modules back into their slots.**

#### 3.3.1 Install VAXBI Parts

**Install the terminator, node ID plugs, bus bar assembly, and FBE removed from the old cage. Attach the side and inner mounting plates. Finally, install new foam air seals.**

Figure 3-10: Installation of Foam Air Seals

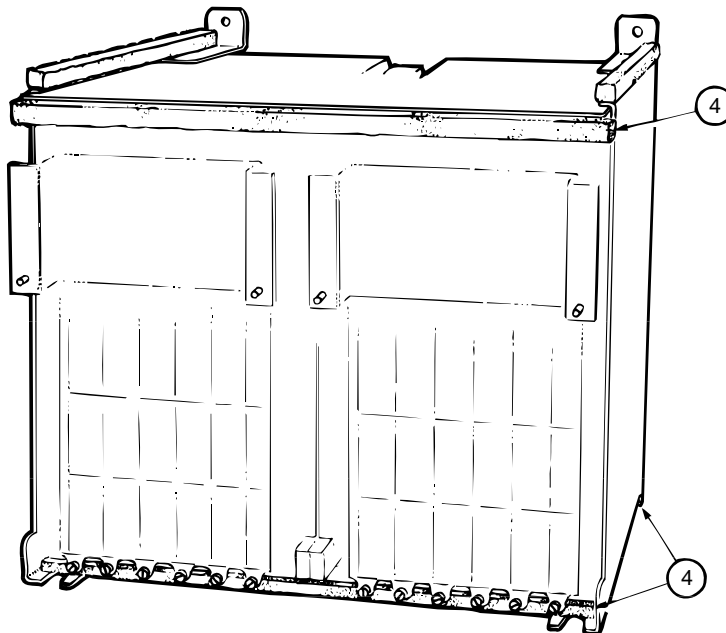

msb-0115A-90

1. Check the pins on the FBE and straighten them if necessary. Fold the flexible cable between the two cages and position the FBE over the locating studs on the replacement cage (see Figure 3-7). Ease the pins into the holes and turn the jackscrews one-half to one turn each.

**CAUTION:** *The FBE pins must be properly aligned. A misaligned pin will buckle when the jackscrews are tightened.*

2. Tighten the jackscrews in stages; do not tighten one completely before tightening the other. Torque the jackscrews to 6 (+/-1) inch-pounds.
3. On the replacement cage, install the parts you removed from the defective VAXBI card cage:
  - Terminator
  - Node ID plugs
  - Bus bar assembly and ground bus jumper, in the reverse order of the removal. Torque screws to 9 (+/-1) inch-pounds.
  - Side and inner mounting plates
4. Replace the three foam air seals: the top front of the backplane and the bottom surfaces of the cages, back and front. See ④ in Figure 3-10.
5. The new cage, the H9400-AA, is shipped with six transition headers installed. For the slots that are to hold the CIBCA and KDB50 options, remove the transition headers.

### 3.3.2 Install the Card Cages in the Cabinet

**Replace the card cages and the system control assembly, attach cables, and replace the bulkhead tray, modules, and clear door.**

Figure 3-11: VAXBI Card Cages

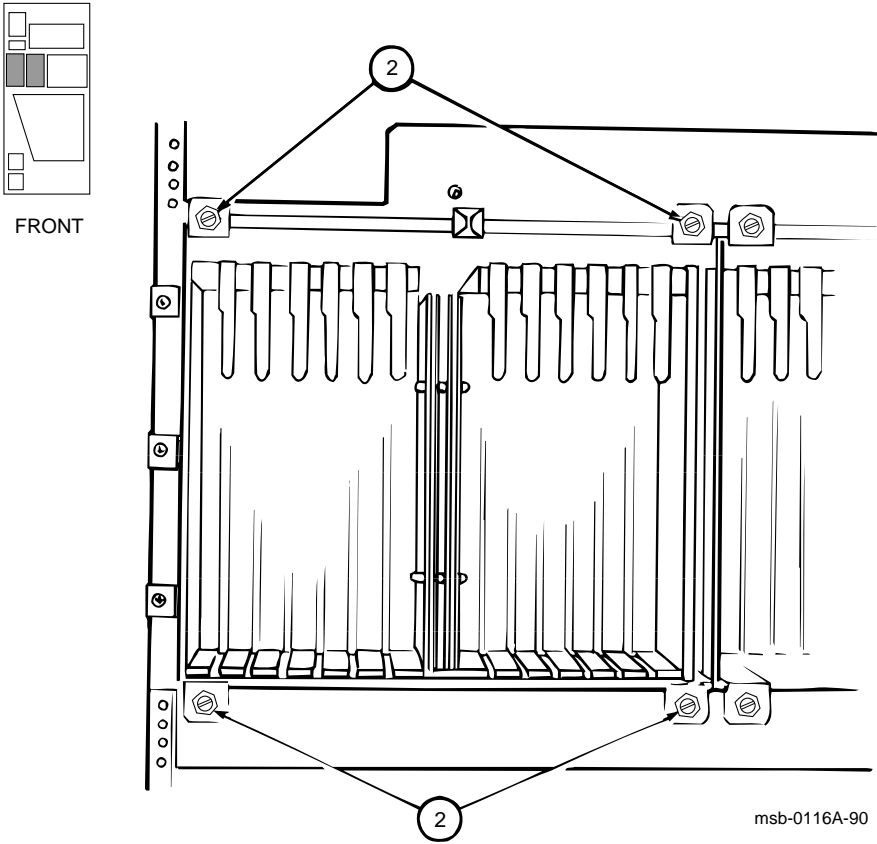

1. Slide the VAXBI card cages into the system cabinet taking care not to damage the power harnesses or bus bars. You will also need to pull the cages from the back. This step requires two persons.
2. Install the four mounting nuts that secure the VAXBI cage assembly to the system cabinet. See ❷ in Figure 3–11.
3. Reinstall the system control assembly (see Section 4.2 for instructions).
4. Screw on the transition headers containing the CIBCA and KDB50 cables. Tighten the screws in stages: do not tighten one completely before tightening the other. Torque both screws to 6 (+/-1) inch-pounds, using the torque screwdriver.
5. Attach the other signal connections in the I/O area.
6. Reattach the power connections.  
At the H7214 regulator, torque screws to 27 (+/-5) inch-pounds.  
On the bus bars torque screws to 9 (+/-1) inch-pounds.
7. If the card cage has a DEBNI adapter, attach J2 of the Ethernet power cable to the H7214 regulator. Reattach J4 to the H7214 regulator.
8. Put the I/O bulkhead tray back into place at the rear of the cabinet.  
**CAUTION:** *You must wear an antistatic wrist strap attached to the cabinet when you handle any modules.*
9. Insert the modules into the VAXBI card cages.
10. Replace and latch the clear door.
11. Turn on system power and check that all nodes pass self-test.
12. Rehang the front cabinet door.

**NOTE:** *See the Verification chapter in the <REFERENCE>(VAX\_XXXX) Series Installation Guide for complete acceptance instructions.*

### 3.4 VAXBI Expansion and Configuration Rules

The system cabinet has two VAXBI cages configured to provide one 12-slot VAXBI channel for I/O. Slot 1 holds the XMI-to-VAXBI adapter module (DWMBB/B), leaving 11 slots for I/O modules. Four more cages can be installed in a VAXBI expander cabinet to provide four additional VAXBI channels, for a total of five VAXBI channels. A maximum of 31 slots is available for I/O adapters.

Figure 3-12: Numbering of VAXBI Slots

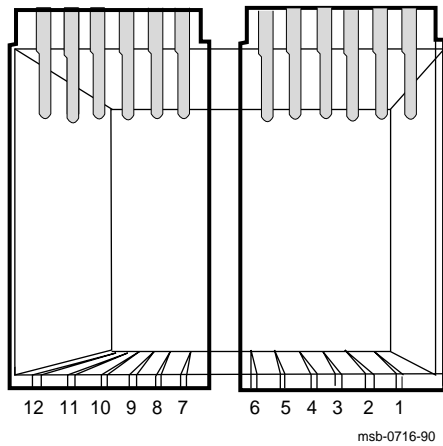

The cage and backplane were designed so that any module or node can reside in any slot (except slot 1). Since the module that drives the clock must be in slot 1, that slot is reserved for the DWMBB/B module. (See Figure 3-12 for the numbering of VAXBI slots.)

VAXBI node numbers derive from node ID plugs that plug into the backplane. A node, which can be more than one module, is assigned the node number of the plug that is inserted into the slot of the module with the VAXBI Corner. Multimodule nodes must be in adjacent slots.

Constraints on adding VAXBI options include:

- Power requirements for the options
- Memory latency time needed to access memory

See Digital's *Systems and Options Catalog* for VAXBI option configurations in <REFERENCE>(VAX\_XXXX) systems. See Appendix B of the *VAXBI Options Handbook* for power requirements of various options. The DWMBB/B module requires 6 amps.

## 3.5 VAXBI Troubleshooting

**When you install modules in the VAXBI card cages, several items need to be checked. Table 3-5 gives a checklist of items to troubleshoot.**

**Table 3-5: VAXBI Troubleshooting Checklist**

<b>Symptom</b>	<b>Possible Cause</b>
No power to cages	Clear plastic door not in place or not latched.
Intermittent module response	Poor contact at connector
	Loose cabling at backplane
	Power connector reattached with 7/16" screw instead of 5/16" screw
Module does not appear on self-test results	Loose cabling at backplane
	System not configured correctly
Modules display unusual failures after FBE is removed and replaced	Check FBE pins for buckling or other damage

Clear plastic doors cover the VAXBI and XMI card cages. If these doors are opened when power is still on, a power interlock switch cuts off power from the regulators to either the VAXBI side or to the XMI side, depending on the door opened.

Before turning power back on, make sure the clear plastic doors are in place and latched. You can then push the reset switch on the H7206-B power and logic unit (see Figure 5–11) to return power to the system.

If you receive intermittent module response, or the module does not show up on self-test as being present at all, make sure the module is seated properly, a node ID plug is in place, and the backplane cabling is correct.

Modules may fail self-test because of poor contact at the connector. A thorough cleaning of the gold pads on the module and of the connector in the card cage corrects this contact failure. If the connections seem to be faulty, clean the contact areas of the connector and module. Table 3–6 lists tools and supplies for connector cleaning.

**Table 3–6: VAXBI Connector Cleaning Supplies**

<b>Item</b>	<b>Part Number</b>	<b>Function</b>
VAXBI tool kit	A2-M1094-10	Maintaining card cages
Paddle wipe handle	47-00116-02	Holding paddle wipes
Paddle wipes	12-26321-01	Cleaning contact area inside ZIF connectors
Gold-wipes™	49-01603-00	Cleaning module connector contact area
Protective goggles	29-16141-10	Eye protection
Nitrile gloves	29-26403-00	Hand protection

™Gold-wipes is a trademark of TEXWIPE.



# System Control Assembly

---

This chapter describes the specifications and maintenance of the system control assembly and its subassemblies. Sections include:

- System Control Assembly Specifications
- System Control Assembly Removal and Replacement
- XTC Power Sequencer Specifications
- XTC Removal and Replacement
- Control Panel Assembly Specifications
- Control Panel Assembly Removal and Replacement
- Filter Board and TOY Clock Battery Specifications
- Filter Board and TOY Clock Battery Removal and Replacement
- Tape Drive Specifications
- Tape Drive Removal and Replacement

# 4.1 System Control Assembly Specifications

The system control assembly is located in the upper left front corner of the cabinet. It houses the separate FRUs of the control panel, the XTC, the battery powering the TOY clock, the filter board, and the optional tape drive.

Figure 4-1: System Control Assembly

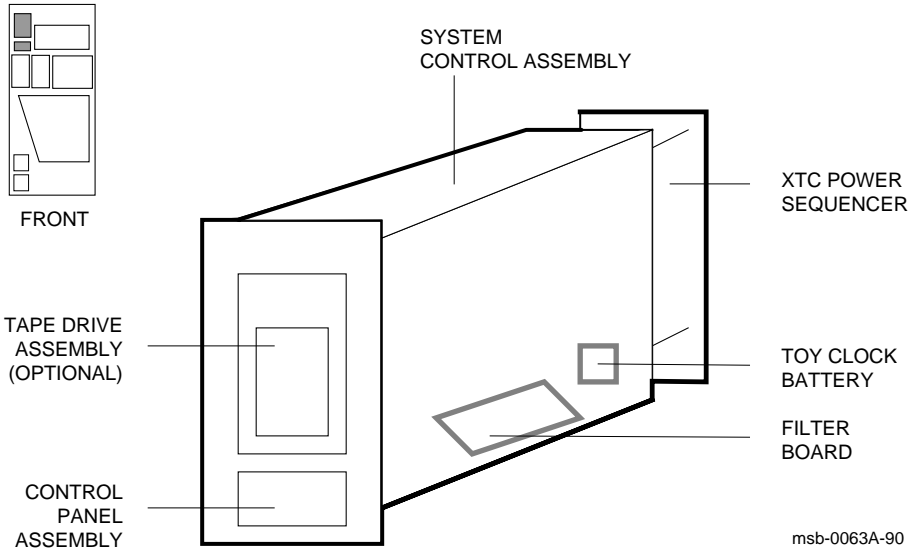

**Table 4–1: System Control Assembly Specifications**

<b>Parameter</b>	<b>Description</b>
<b>Part Number:</b>	70-27867-01
<b>Location:</b>	Upper left front
<b>Dimensions:</b>	11.25" H x 8.5" W x 17.5" D
<b>Weight:</b>	18 lbs, with TK and control panel installed
<b>Signal Cables:</b>	17-01818-01 from the control assembly shield leading to the optional TBK70 adapter's slot at VAXBI backplane segment D
<b>Service From:</b>	Front and rear of cabinet, front door removed
<b>Tools Required:</b>	Large and small Phillips screwdrivers
<b>Subassemblies:</b>	Control panel assembly (54-16574-01) XTC power sequencer (20-29176-02) TOY 3-cell battery (12-19245-02) Optional TK tape drive (TK70-AA) TK filter board (54-18547-01 or 20-29887-01)
<b>Diagnostics:</b>	Control panel assembly lights will light when the control assembly is correctly installed.

## 4.2 System Control Assembly Removal and Replacement

Working mainly from the front of the cabinet, remove or replace the system control assembly using large and small Phillips screwdrivers. The assembly has four screws on the front of the assembly, two screws on the back of the assembly, and one cable.

Figure 4-2: System Control Assembly Removal (Rear)

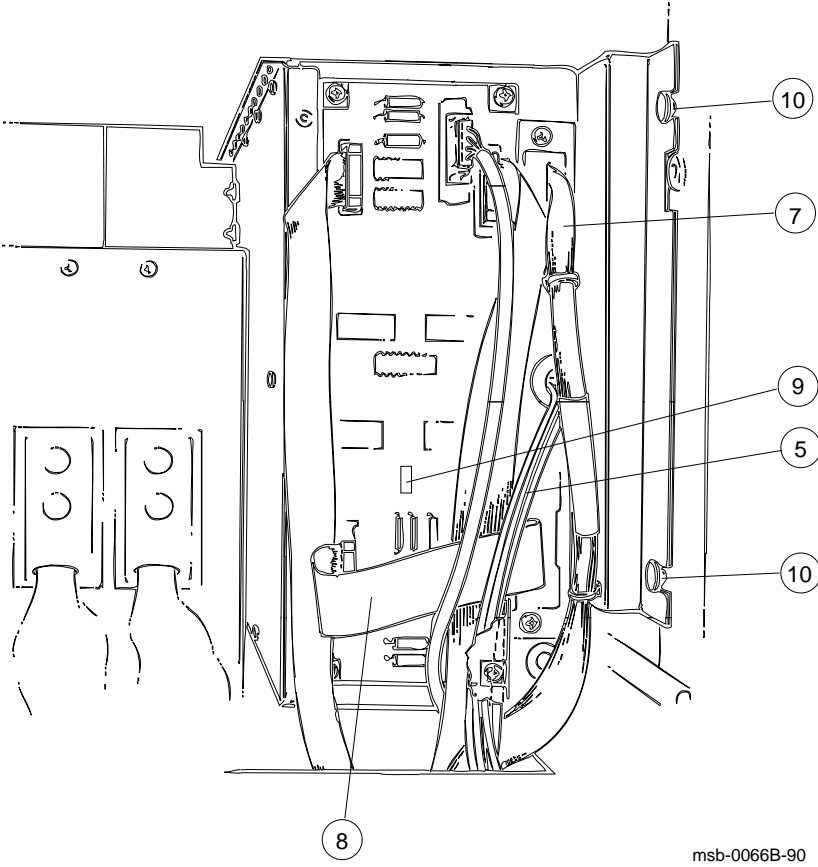

msb-0066B-90

## REMOVAL

1. Perform an orderly shutdown of the system.
2. Turn the control panel upper key switch to Off.
3. Pull the circuit breaker switch and unplug the system.
4. Open and remove the front door. (See Section 6.1.) Open the rear door.
5. Remove the four power cords (orange, black, red, and brown) at the XMI backplane end. See ⑤ in Figure 4-2.
6. Remove the four screws from the corners of the XTC power sequencer module (see Section 4.4), and lay the XTC down with all its connections in place.
7. If present, remove signal cable 17-01818-01 from the upper right corner of the back of the system control assembly. This cable is the control from the TK to VAXBI backplane segment D, at the slot housing the TBK70 adapter. See ⑦.
8. Remove cable 17-01816-01 from J2 at the XTC module. See ⑧.
9. Remove the TOY clock battery backup cable (red and black) from the XTC module. See ⑨.
10. Working from the rear of the cabinet, loosen the two #10-32 screws with a large Phillips screwdriver. See ⑩.

**Figure 4-3: System Control Assembly Removal (Front)**

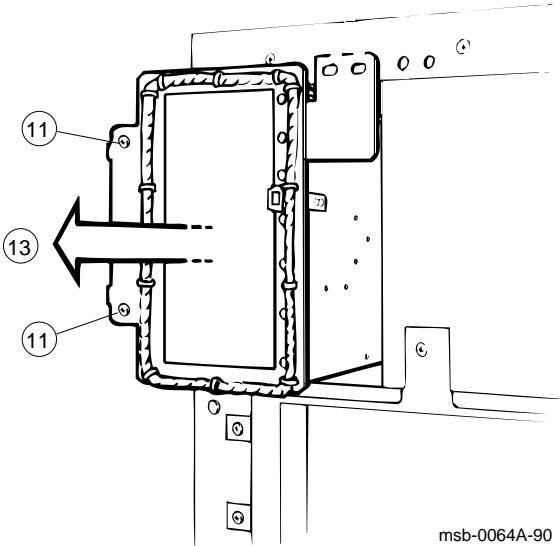

11. Move to the front of the cabinet. Remove the two #10-32 screws on the left side of the system control assembly using a large Phillips screwdriver. See ⑩ in Figure 4-3. Remove one of the two screws on the upper right support panel. Loosen the remaining screw.
12. Supporting the system control assembly with one hand, remove the last loosened screw with your hand.
13. Using both hands, carefully pull the system control assembly forward and out of the cabinet. See ⑬.

## **REPLACEMENT**

1. Install the XTC and the control panel assembly (see Section 4.4 and Section 4.6).
2. As you guide the control assembly into the front of the cabinet, push the control assembly all the way to the left. This will align the screws with their holes in the structure. If you have trouble closing the cabinet door, check the assembly alignment.
3. Reverse Steps 1 through 10 in the Removal section above.

### 4.3 XTC Power Sequencer Specifications

The XTC power sequencer is mounted on the back of the system control assembly. It is wired to the <REFERENCE>(XMI) backplane, the console terminal, the TK tape drive, and the H7214 power regulator.

Figure 4-4: XTC Power Sequencer

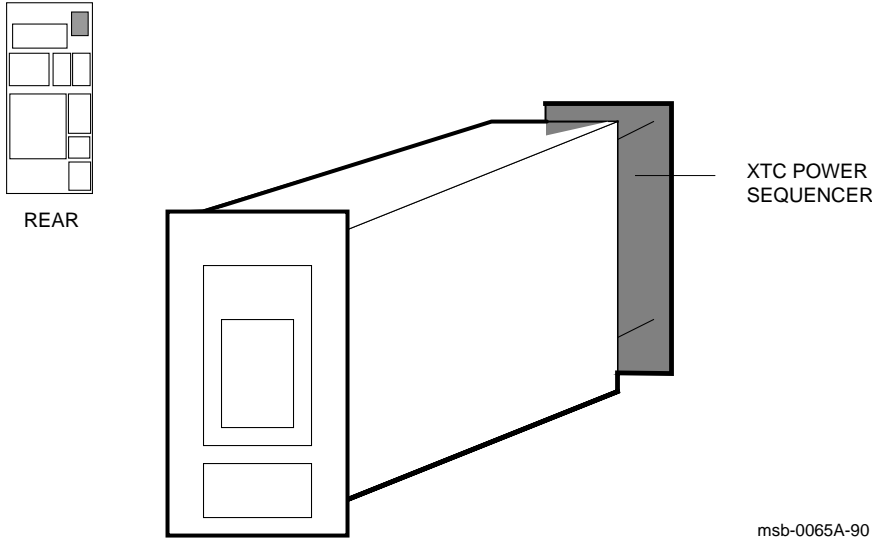

msb-0065A-90



**Table 4–2: XTC Power Sequencer Specifications**

<b>Parameter</b>	<b>Description</b>
<b>Part Number:</b>	54-17243-02 or 20-29176-02
<b>Location:</b>	Upper right rear, mounted on the back of the system control assembly
<b>Dimensions:</b>	2.5" W x 8" H x .06" D
<b>Weight:</b>	Less than 1 lb
<b>Power:</b>	+5V at 0.6 amps +12V at 1.0 amps -12V at 0.1 amps
<b>Cables:</b>	Four ribbon cables and one TOY clock battery cable: 12-19245-02 battery cable, J1 connector with red plug end 17-01498-01 XTC to H7206, J3 14-pin connector 17-01567-01 XTC to console port, J5 10-pin connector 17-01568-02 <REFERENCE>(XMI) to XTC, J4 20-pin connector, 56" long 17-01816-01 XTC to control panel, J2 connector
<b>Service From:</b>	Rear of cabinet, door removed
<b>Tools Required:</b>	Large Phillips screwdriver
<b>Subassemblies:</b>	None
<b>Diagnostics:</b>	Power indicator lights on the control panel will light and the control panel key switches will turn when the XTC power sequencer is correctly installed.

# 4.4 XTC Removal and Replacement

**Remove or replace the XTC power sequencer from the rear of the cabinet.**

**Figure 4-5: XTC Power Sequencer Removal**

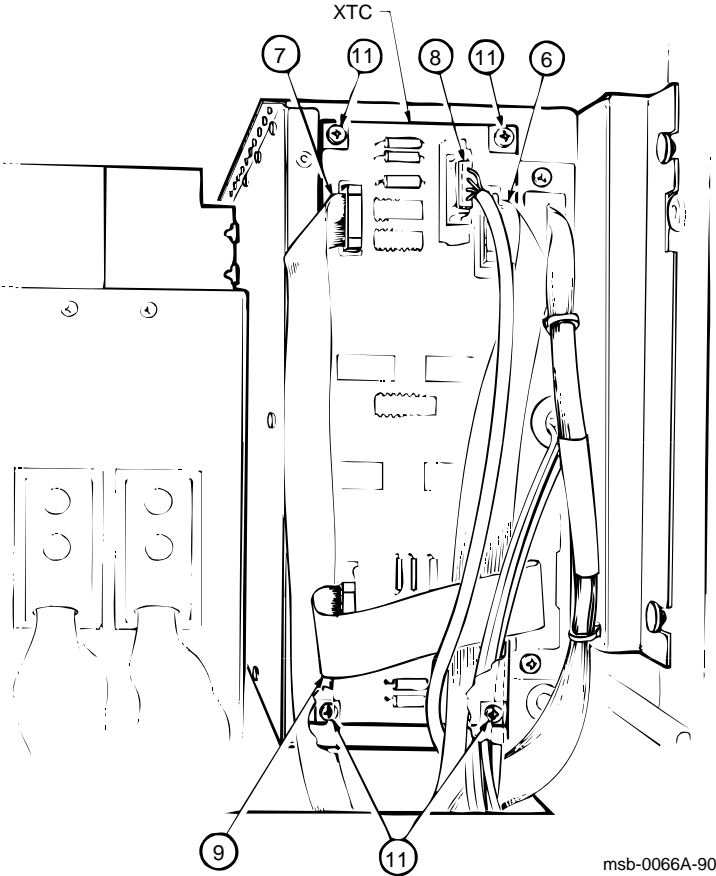

## REMOVAL

1. Perform an orderly shutdown of the system.
2. Turn the control panel upper key switch to Off.
3. Pull the circuit breaker switch.
4. Unplug the system.
5. Open the front and rear doors.
6. Wearing a ground strap, disconnect the 17-01568-02 ribbon cable at J4, which is a 20-pin connector cable leading to the XMI. See ⑥ in Figure 4-5.
7. Disconnect the 17-01498-01 ribbon cable at J3, which is a 14-pin connector cable leading to the H7206-B power and logic box. See ⑦.
8. Disconnect the 17-01567-02 cable at J5, which is a 10-pin connector cable leading to the console port. See ⑧.
9. Disconnect the 17-01816-01 ribbon cable at J2, which leads to the control panel on the system control assembly. See ⑨.
10. Disconnect the 12-19245-02 lead with a red plug end at the J1 connector; the cable leads to the TOY clock battery in the system control assembly. This connection, not shown on Figure 4-5, is behind the ribbon cable disconnected from J2 in the previous step.
11. Use a large Phillips screwdriver to remove the four #6-32 screws located on each corner of the XTC power sequencer. See ⑩.
12. Pull the XTC toward you and remove.

## REPLACEMENT

- Reverse Steps 1 through 12 in the Removal section above.

# 4.5 Control Panel Assembly Specifications

The control panel assembly (54-16574-01) is in the upper left front of the cabinet.

Figure 4-6: Control Panel Assembly

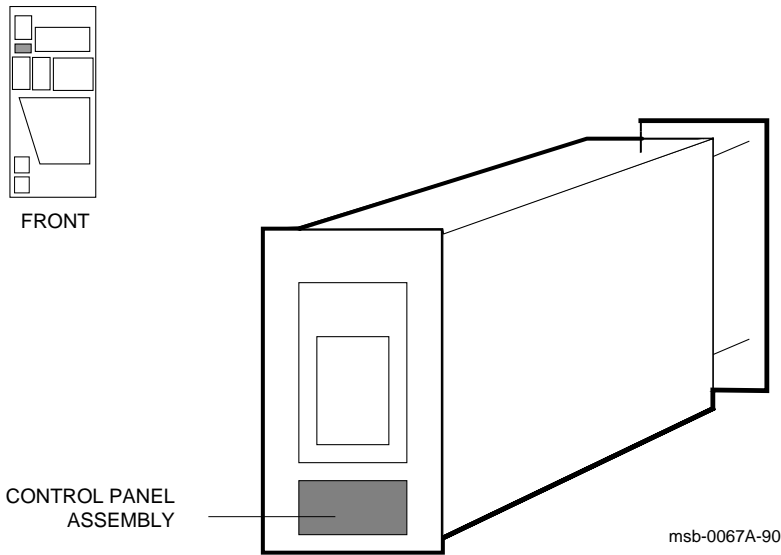

**Table 4–3: Control Panel Assembly Specifications**

<b>Parameter</b>	<b>Description</b>
<b>Part Number:</b>	54-16574-01
<b>Location:</b>	Front upper left corner
<b>Dimensions:</b>	4.25" W x 2.75" H x 1.75" D
<b>Weight:</b>	3 ounces
<b>Cables:</b>	17-01818-01 cable from the J1 20-pin connector to the assembly bulk-head
<b>Service From:</b>	Front of cabinet, door open
<b>Tools Required:</b>	Large Phillips screwdriver
<b>Subassemblies:</b>	None
<b>Diagnostics:</b>	Control panel assembly lights light when power is turned on by the control panel key switch.

## 4.6 Control Panel Assembly Removal and Replacement

Working from the front of the cabinet, remove the control panel assembly using a large Phillips screwdriver. The panel assembly has one cable, 17-01818-01.

Figure 4-7: Control Panel Assembly Removal

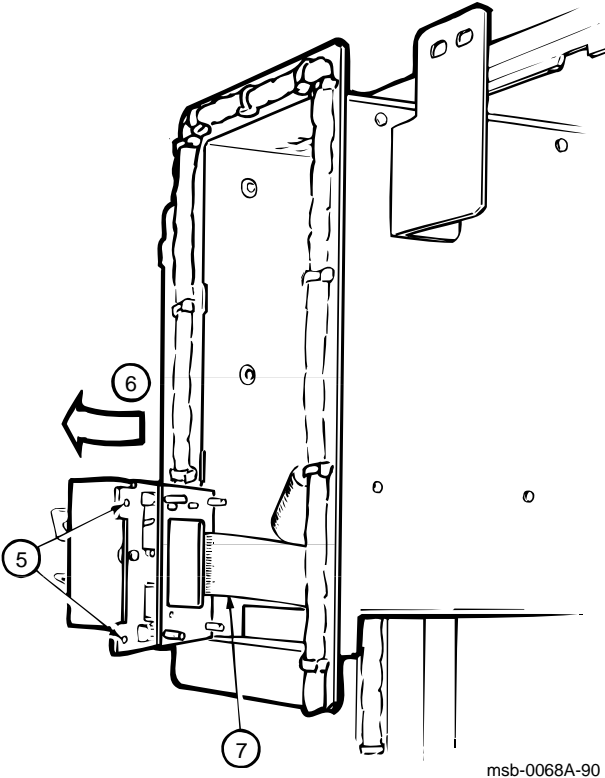

msb-0068A-90

## **REMOVAL**

1. Conduct an orderly shutdown of the system.
2. Turn the control panel upper key switch to Off.
3. Pull the circuit breaker switch. Unplug the system.
4. Open the front door.
5. Using a large Phillips screwdriver, remove the two #6-32 screws on the right side of the panel. See ⑤ in Figure 4-7.
6. Swing the unit out and to the left, and pull it toward you. See ⑥.
7. Disconnect cable 17-01818-01 at the J1 20-pin connector. See ⑦.

## **REPLACEMENT**

1. Connect cable 17-01818-01 to J1. The connection is not keyed, but the cable has a colored stripe. Be sure this stripe is on top when you reconnect the cable.
2. Place the tabs on the left edge of the control panel in the slots on the control assembly.
3. With the tabs inserted, swing the module into the opening.
4. Using a large Phillips screwdriver, insert and tighten two #6-32 screws.
5. Close the front door.

## 4.7 Filter Board and TOY Clock Battery Specifications

The filter board and TOY clock battery are located on the inside floor of the control assembly in the upper left front of the cabinet. The battery is a 3-cell TOY clock battery, part number 12-19245-02, and it powers the time-of-year clock on the XTC power sequencer module. The filter board part number is 54-18547-01 or 20-29887-01.

Figure 4-8: Filter Board and TOY Clock Battery

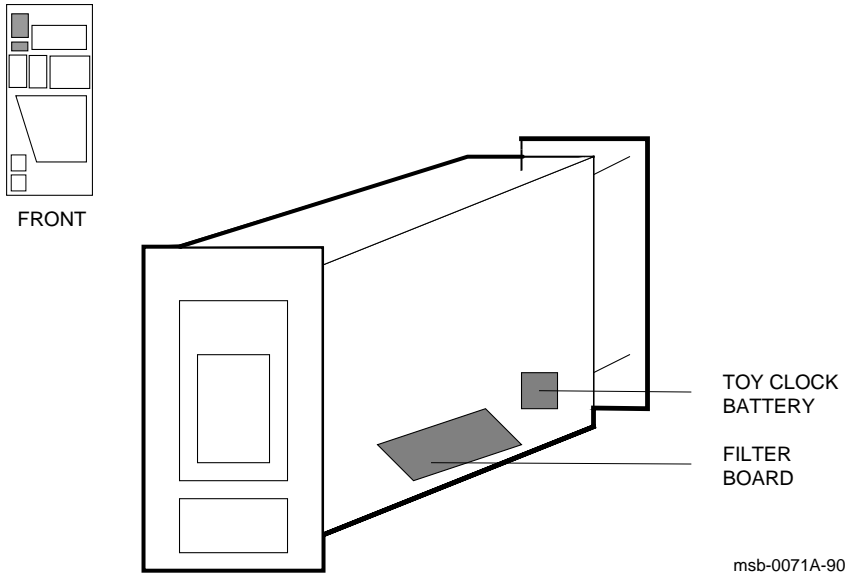



**Table 4–4: Filter Board Specifications**

<b>Parameter</b>	<b>Description</b>
<b>Part Number:</b>	54-18547-01 or 20-29887-01
<b>Location:</b>	Inside of system control assembly
<b>Dimensions:</b>	3 1/4" x 5 1/4"
<b>Weight:</b>	Less than 1 lb
<b>Service From:</b>	Inside of system control assembly
<b>Tools Required:</b>	Large Phillips screwdriver
<b>Diagnostics:</b>	TK lights

**Table 4–5: TOY Clock Battery Specifications**

<b>Parameter</b>	<b>Description</b>
<b>Part Number:</b>	12-19245-02
<b>Location:</b>	Inside of system control assembly
<b>Dimensions:</b>	1 3/4" x 1 1/2"
<b>Weight:</b>	Less than 1 lb
<b>Power:</b>	3-cell, 3.75V, .18mA
<b>Cable:</b>	Lead to XTC power sequencer
<b>Service From:</b>	Front of cabinet, door removed
<b>Tools Required:</b>	None
<b>Diagnostics:</b>	Time-of-year clock works

## 4.8 Filter Board and TOY Clock Battery Removal and Replacement

To remove or replace the filter board or the 3-cell time-of-year clock battery, first remove the system control assembly (see Section 4.2). Then remove the side panel of the system control assembly.

Figure 4-9: Filter Board and TOY Clock Battery Removal

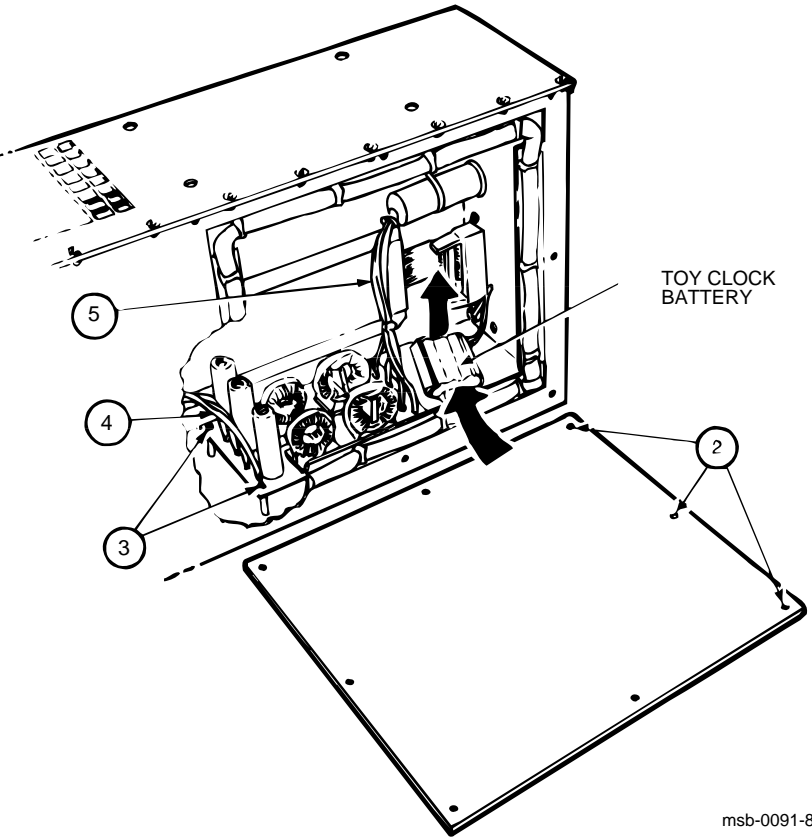

msb-0091-89

### **REMOVAL OF FILTER BOARD**

1. Remove the system control assembly (see Section 4.2) and, if present, the TK tape drive (see Section 4.10).
2. Using a large screwdriver, unscrew the side panel of the system control assembly. See ❷ in Figure 4-9.
3. Remove the screw from each corner of the filter board, using a large screwdriver. See ❸.
4. If the optional TK tape drive is present, disconnect the power cable from J7 at the back of the tape drive. See ❹.
5. Cut the tiewrap that holds the ferrite bead on the outside of the box. Remove the filter assembly. See ❺. Working from the inside of the system control assembly, gently pull the cable through the hole at the rear of the system control assembly.
6. Lift the filter board up and out of the system control assembly.

### **REPLACEMENT OF FILTER BOARD**

- Reverse Steps 1 through 6 above.

### **REMOVAL OF TOY CLOCK BATTERY**

1. Remove the system control assembly (see Section 4.2).
2. Using a large screwdriver, unscrew the side panel of the system control assembly. See ❷ in Figure 4-9.
3. To remove the battery, disconnect the 2-pin battery lead at J1 on the XTC power sequencer. Push the battery up and out of the plastic holder, pulling the lead through the system control assembly shielding.

### **REPLACEMENT OF TOY CLOCK BATTERY**

1. To replace the battery, snap it into the holder and connect the lead at J1 on the XTC power sequencer.
2. Reverse Steps 1 and 2 above.

# 4.9 Tape Drive Specifications

**The optional TK tape drive is located in the system control assembly in the upper left front of the cabinet.**

**Figure 4-10: Tape Drive**

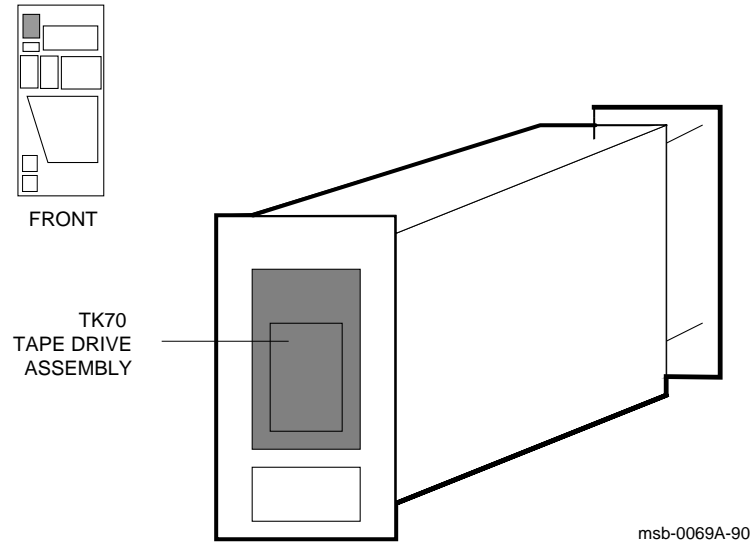

**Table 4–6: TK Tape Drive Assembly Specifications**

<b>Parameter</b>	<b>Description</b>
<b>Part Number:</b>	TK70
<b>Location:</b>	Upper left front, housed in the system control assembly
<b>Dimensions:</b>	5.80" W x 3.38" H x 8.79" D
<b>Weight:</b>	5.13 lbs
<b>Power:</b>	One power cord from the TK filter board
<b>Cable:</b>	One signal cable 17-02833-01 to the system control assembly
<b>Service From:</b>	Front of cabinet, door removed
<b>Tools Required:</b>	None
<b>Subassemblies:</b>	None
<b>Diagnostics:</b>	All three LEDs on TK70 are lit when power-up diagnostic is in progress; tape-in-use LED (yellow) lights to indicate tape is ready for use.

## 4.10 Tape Drive Removal and Replacement

**Working from the front of the cabinet, remove or replace the tape drive using the captive screw attached to the control assembly unit on the right. The tape drive has one power and one signal cable.**

Figure 4-11: Tape Drive Removal

newart:msb0070a.ps

## **REMOVAL**

1. Turn the control panel upper key switch to Off.
2. Open the front door.
3. Loosen the captive screw. See ③ in Figure 4-11.
4. Being careful not to rip the ribbon cable, pull the tape drive out toward you. See ④.
5. Holding the unit in your hand, disconnect the power cord labeled P1. See ⑤.
6. Disconnect the signal cable 17-02833-01 at J7 on the tape drive. See ⑥.

## **REPLACEMENT**

- Reverse Steps 1 through 6 above, being careful not to twist the signal cable.
- As you push the unit in, hold the signal cable flush to the left side of the unit so that the service loop remains untangled and is installed smoothly. Tuck the end loop in if it protrudes when the tape drive is installed.

## Chapter 5

# Power Subsystem

---

This chapter gives specifications and removal and replacement procedures for the power modules. Sections include:

- Power Subsystem Design
- Power Specifications
- Power Modules
- H7214 Power Regulator
- H7214 Power Regulator Removal and Replacement
- H7215 Power Regulator
- H7215 Power Regulator Removal and Replacement
- H7242 Power Regulator
- H7242 Power Regulator Removal and Replacement
- H7206-B Power and Logic Unit
- H7206-B Power and Logic Unit Removal and Replacement
- H7206-B Fan Removal and Replacement
- H405 AC Power Controller
- H405 AC Power Controller Removal and Replacement
- 50 Hz Transformer
- 50 Hz Transformer Removal and Replacement
- H7236-A Battery Backup Unit
- H7236-A Battery Backup Unit Removal and Replacement
  - Fan Removal and Replacement
  - Battery Pack Removal
  - Battery Pack Replacement
  - Enclosure Removal and Replacement



## 5.1 Power Subsystem Design

**Figure 5-1 is a block diagram of the <REFERENCE>(VAX\_XXXX) power subsystem.**

**Figure 5-1: Power Subsystem Design**

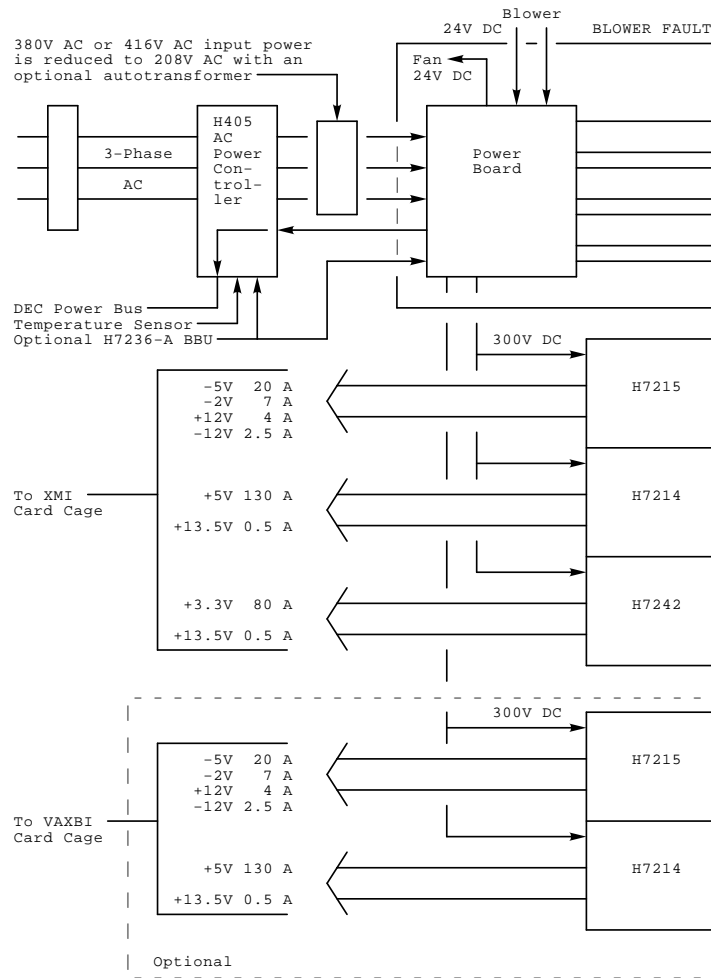

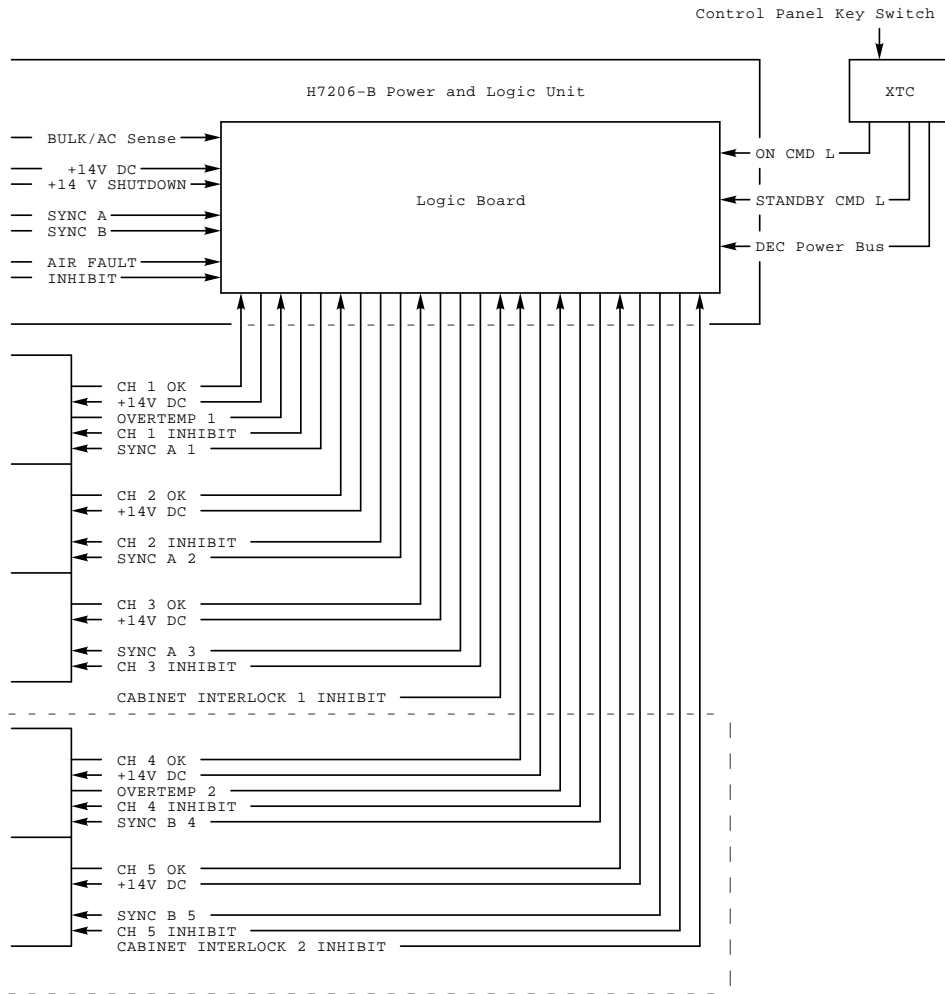

msb-p377r-90

# 5.2 Power Specifications

Figure 5-2 shows the physical arrangement of the power regulators in the cabinet. Table 5-1 and Table 5-2 list the DC output voltages the power regulators supply to the XMI and VAXBI card cages. AC output specifications are listed in Table 5-3.

Figure 5-2: DC Power Regulators in Cabinet (Rear View)

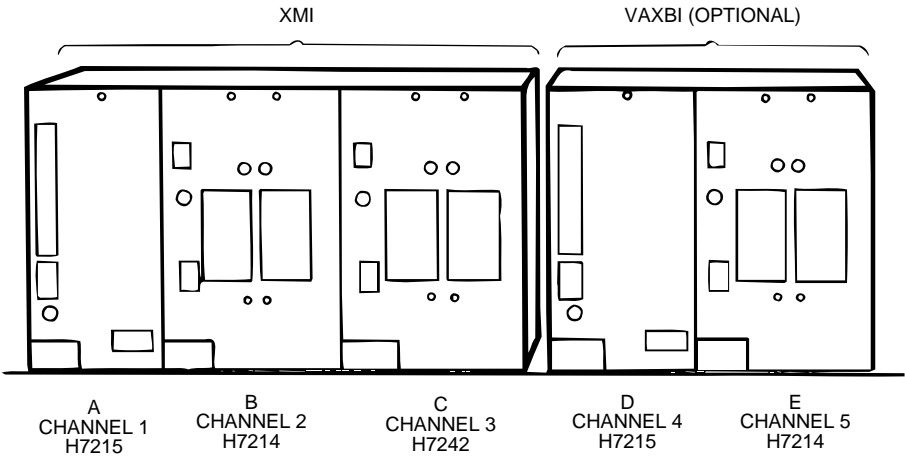

msb-0073A-90

**Table 5–1: XMI Side—DC Output Specifications**

<b>DC Voltage</b>	<b>Current</b>	<b>For:</b>	<b>From Regulator:</b>
+12V	4 A	RS-232 and TK tape drive supply	A (Channel 1)
-12V	2.5 A	RS-232 supply	A (Channel 1)
-5V	20 A	ECL logic	A (Channel 1)
-2V	7 A	ECL logic	A (Channel 1)
+5V	130 A	Logic and memory supply	B (Channel 2)
+13.5V	0.5 A	Ethernet transceiver B	B (Channel 2)
+3.3V	80 A	Logic supply	C (Channel 3)
+13.5V	0.5 A	Ethernet transceiver C	C (Channel 3)

**Table 5–2: VAXBI Side—DC Output Specifications**

<b>DC Voltage</b> <sup>1</sup>	<b>Current</b>	<b>For:</b>	<b>From Regulator:</b>
+12V	4 A	RS-232 and tape drive supply	D (Channel 4)
-12V	2.5 A	RS-232 supply	D (Channel 4)
-5V	20 A	ECL logic	D (Channel 4)
-2V	7 A	ECL logic	D (Channel 4)
+5V	130 A	Logic supply	E (Channel 5)
+13.5V	0.5 A	Ethernet transceiver E	E (Channel 5)

<sup>1</sup>The H7206-B power and logic unit supplies 24V DC at 0–4 amps to the blowers and air-flow sensor.

**Table 5–3: AC Output Specifications**

<b>Type</b>	<b>For:</b>
Two unswitched external IEC 320 receptacles fused at 10 amps	Optional in-cabinet disks and BBU
One unswitched internal IEC 320 receptacle fused at 2 amps	<b>Not to be used</b>

# 5.3 Power Modules

**Most of the power modules can be seen from the rear of the cabinet.**

**Figure 5-3: Location of Power Modules (Rear View)**

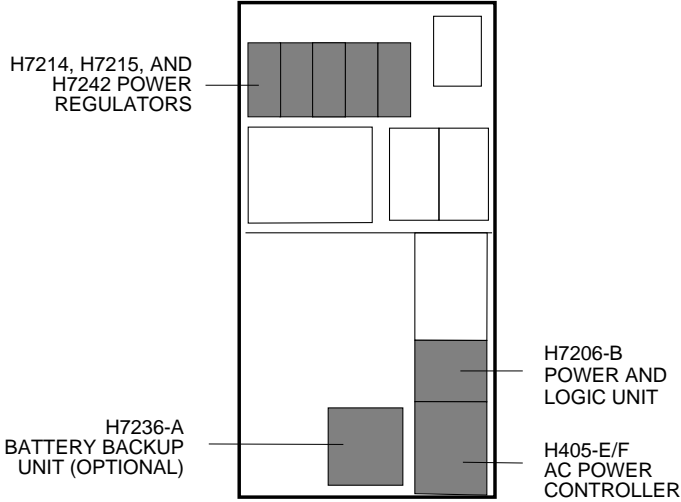

msb-0308-90

Power modules are listed in Table 5-4.

**Table 5-4: Power Modules**

<b>Part Number</b>	<b>Module</b>	<b>Quantity</b>	<b>60 Hz System</b>	<b>50 Hz System</b>
H7214	Power regulator	1*	X	X
H7215	Power regulator	1*	X	X
H7242	Power regulator	1	X	X
H7206-B	Power and logic unit	1	X	X
H7236-A	Battery backup unit	1	X	X
H405-E	AC power controller	1	X	-
H405-F	AC power controller	1	-	X
16-28393-01	50 Hz transformer	1	-	X

\* Quantity is 2 if there is a VAXBI in the system cabinet

# 5.4 H7214 Power Regulator

The system has one or two H7214 power regulators. One supplies power to the <REFERENCE>(XMI) backplane; the other, if needed, supplies power to the optional VAXBI backplane. Each power regulator can also supply +13.5V to an Ethernet transceiver. These regulators are located in the upper part of the cabinet, along with the H7215 and H7242 regulators.

Figure 5-4: H7214 Power Regulators (Rear View)

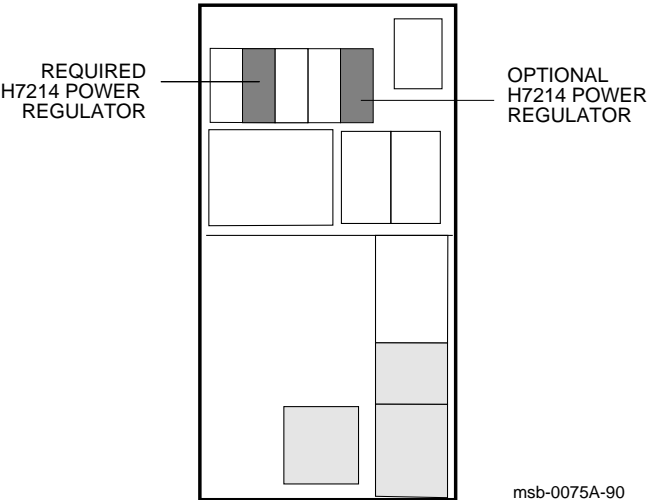

**Table 5–5: H7214 Power Regulator Specifications**

<b>Parameter</b>	<b>Description</b>
<b>Part Number:</b>	H7214
<b>Location:</b>	Upper part of cabinet
<b>Dimensions:</b>	6" H x 4.5" W x 12" D
<b>Weight:</b>	8 lbs
<b>Cables for &lt;REFERENCE&gt;(XMI):</b>	17-01497-02 control/status cable, 34-pin connector 17-01446-01 bulk power cable 17-01525-01 remote sense cable +13.5V output cable, 2-pin connector (part of 17-01496-01 Ethernet cable) +5V DC and return leads attached to XMI bus bar assembly
<b>Cables for VAXBI:</b>	17-01666-01 control/status cable, 24-pin connector, to H7206-B 17-01447-01 bulk power cable to H7206-B 17-01525-01 remote sense cable to VAXBI bus bar +13.5V output cable, 2-pin connector (part of 17-01496-01 Ethernet cable) +5V DC and -5V DC leads attached to VAXBI bus bar assembly
<b>Service From:</b>	Front and rear of cabinet, doors open
<b>Tools Required:</b>	Flat and Phillips screwdrivers, 5/16" nutdriver
<b>Diagnostics:</b>	Green LED lights when +5V output is within regulation

The H7214 power regulator develops two regulated DC outputs: +5V used to power system logic and memory loads, and the +13.5V, available for an Ethernet transceiver.

Each H7214 has one green LED that is visible from the rear of cabinet. The LED lights to indicate that the +5V output is properly regulated.

**NOTE:** *The green LED does not indicate the status of the +13.5V Ethernet output.*

The power regulator consists of a single printed circuit board mounted on a right-angle bracket. The bracket has guiding edges for use when inserting the regulator into the cabinet.



# 5.5 H7214 Power Regulator Removal and Replacement

**Remove and replace the H7214 power regulator from the rear of the cabinet.**

**WARNING:** *High voltages are present in the H7214 power regulator. After power has been removed, wait at least 2 minutes before working on the unit.*

**Figure 5-5: H7214 Power Regulator Removal**

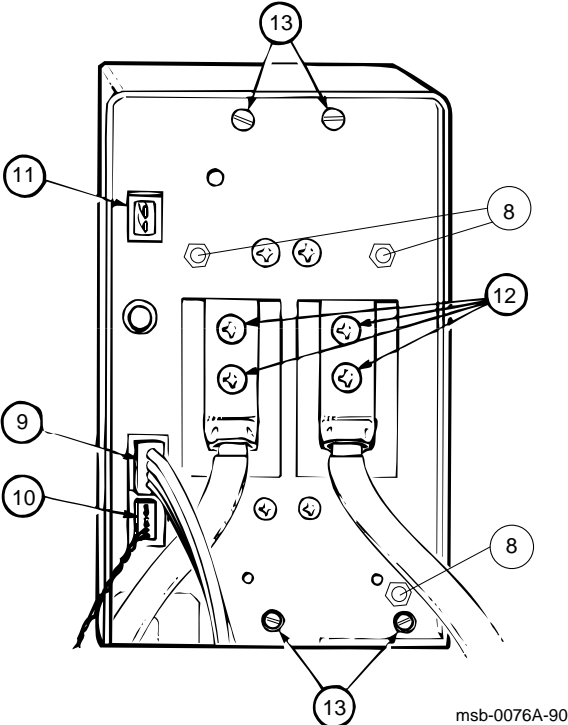

## REMOVAL

1. Perform an orderly shutdown of the system.
2. Turn the upper key switch on the front control panel to Off.
3. Pull the main circuit breaker on the AC power controller to Off.
4. Unplug system power cord; wait 2 minutes for capacitors to discharge.
5. Open the front and rear doors.
6. At the front of the cabinet, disconnect the bulk power cable by releasing the fastener clip and pulling.
7. At front of cabinet, loosen one captive screw securing regulator.
8. At the rear of the cabinet, use a 5/16 inch nutdriver to remove the three nuts and the plastic cover. See ③.
9. Disconnect the control/status cable. See ⑨ in Figure 5-5. On the XMI side, disconnect cable 17-01497-02 from J1. On the VAXBI side, disconnect cable 17-01666-01 from J1.
10. Disconnect the 17-01525-01 remote sense cable from J4. See ⑩.
11. Disconnect the +13.5V cord (part of 17-01496-01) from J2 (if Ethernet connection is present). See ⑪.
12. Disconnect the bus bar leads by removing the four screws. See ⑫. Work the bus bar leads down into the XMI service area.
13. Using a flat screwdriver, loosen the four slotted screws. See ⑬.
14. Support the bottom of the H7214 as you pull it from the cabinet.

## REPLACEMENT

- Reverse Steps 1 through 14 above.

**NOTE:** *Make sure the lugs connecting the bus bar leads do not contact the sheet metal bracket around the mounting points.*

*The H7214 ground reference wire is connected to the regulator's circuit board and return bus bar by a screw and washer. Make sure the wire is intact and properly connected. Tuck the wire out of the way when inserting the regulator into the system.*

# 5.6 H7215 Power Regulator

The system has one or two H7215 power regulators. One supplies power to the <REFERENCE>(XMI) backplane; the other, if needed, supplies power to the optional VAXBI backplane. These regulators are located in the upper part of the cabinet, along with the H7214 and H7242 power regulators.

Figure 5-6: H7215 Power Regulators (Rear View)

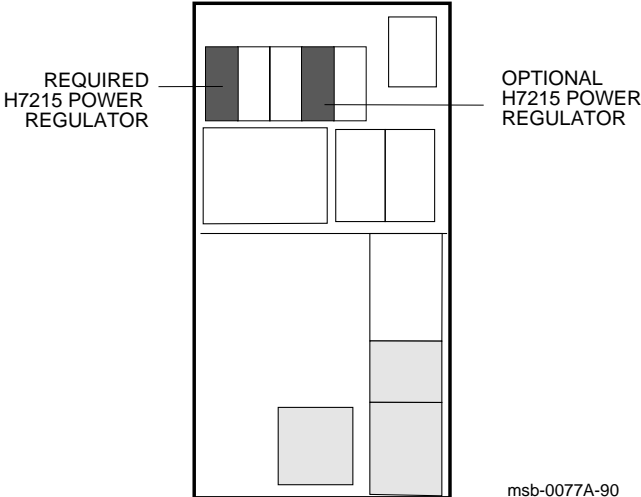

**Table 5–6: H7215 Power Regulator Specifications**

<b>Parameter</b>	<b>Description</b>
<b>Part Number:</b>	H7215
<b>Location:</b>	Upper part of cabinet
<b>Dimensions:</b>	6" H x 3.5" W x 12" D
<b>Weight:</b>	5 lbs
<b>Cables for XMI:</b>	17-01446-01 bulk power cable from H7206-B, 3-pin connector 17-01497-02 control/status cable from H7206-B, 10-pin connector for signals and 2-pin Mate-N-Lok connector for interlock switch 17-01566-01 power distribution cable to XMI, 32-pin connector
<b>Cables for VAXBI:</b>	17-01447-01 bulk power cable for H7206-B, 3-pin connector 17-01666-01 control/status cable from H7206-B, 10-pin connector for signals and 2-pin Mate-N-Lok connector for the interlock switch 17-01523-01 power distribution cable to VAXBI, 32-pin connector
<b>Service From:</b>	Front and rear of cabinet, doors open
<b>Tools Required:</b>	Flat screwdriver
<b>Diagnostics:</b>	Green LED lights when voltages are in regulation

The H7215 develops four regulated DC output voltages: -5V and -2V for ECL devices and +12V and -12V for communications devices and the optional tape drive.

The H7215 has a thermal sensor. If the H7215 overheats on the XMI side, an OVER TEMP signal is sent to the H7206-B logic board. The H7206-B will then inhibit all regulator outputs to the XMI. The same is true for the regulators on the VAXBI side.

Each regulator has a green LED that lights when all four output voltages are in regulation. The LEDs are visible from the rear of the cabinet.

The power regulator consists of two printed circuit boards mounted on a right-angle bracket. The bracket has guiding edges for use when inserting the regulator into the system.

## 5.7 H7215 Power Regulator Removal and Replacement

Working mainly from the rear of the cabinet, remove and replace the H7215 power regulator using a flat screwdriver. The assembly has three captive screws, one control/status cable, and two power cables.

**WARNING:** *High voltages are present in the H7215 power regulator. After power has been removed, wait at least 2 minutes before working on the unit.*

Figure 5-7: H7215 Power Regulator Removal

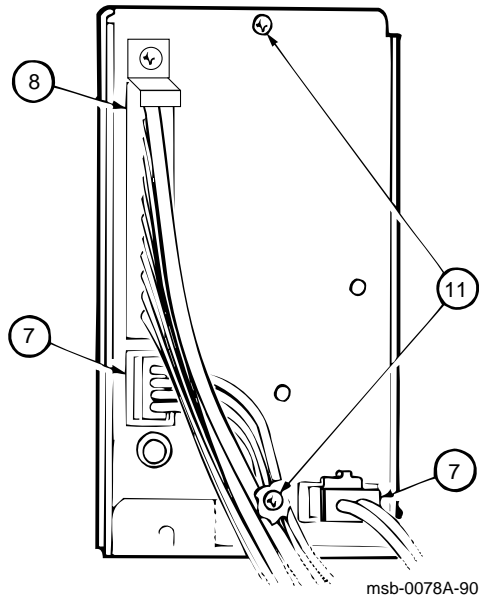

## REMOVAL

1. Perform an orderly shutdown of the system.
2. Turn the upper key switch on the front control panel to Off.
3. Pull the main circuit breaker on the AC power controller to the Off position.
4. Unplug the system power cord.
5. Wait 2 minutes for the capacitors to discharge.
6. Open the front and rear doors.
7. Working from the rear of the cabinet, disconnect the control/status cable by pulling out the 10-pin connector at J2 and the 2-pin Mate-N-Lok connector at INTERLOCK. See ⑦ in Figure 5-7. On the XMI side, this disconnects cable 17-01497-02. On the VAXBI side, this disconnects cable 17-01666-01.
8. Remove the cable retainer and disconnect the power distribution cable from J3. See ⑧. (Note that this 32-pin connector is keyed.) On the XMI side, this disconnects cable 17-01566-01. On the VAXBI side, this disconnects cable 17-01523-01.
9. At the front of the cabinet, disconnect the bulk power cable from J1. This cable has a 3-pin Mate-N-Lok connector. On the XMI side, this disconnects cable 17-01446-01. On the VAXBI side, this disconnects cable 17-01447-01.
10. At the front of the cabinet, loosen the one captive screw securing the H7215.
11. At the rear of the cabinet, use a flat screwdriver to loosen the screws at the top and bottom of the power regulator. See ⑩.
12. Support the bottom of the H7215 as you pull it out of the cabinet.

## REPLACEMENT

- Reverse Steps 1 through 12 above.
- Be sure to position the power regulator on the guide rail when you insert it into the cage.
- Note the gray dot on the control/status cable connector. When installing this cable, make sure the dot is on the top side.

# 5.8 H7242 Power Regulator

The system has one H7242 power regulator that supplies power to the <REFERENCE>(XMI) backplane. This regulator is located in the upper part of the cabinet, along with the H7214 and H7215 power regulators.

Figure 5-8: H7242 Power Regulator (Rear View)

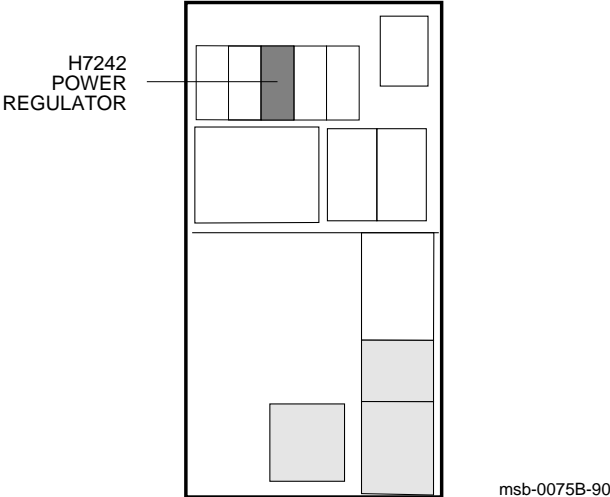

**Table 5–7: H7242 Power Regulator Specifications**

<b>Parameter</b>	<b>Description</b>
<b>Part Number:</b>	H7242
<b>Location:</b>	Upper part of cabinet
<b>Dimensions:</b>	6" H x 4.5" W x 12" D
<b>Weight:</b>	8 lbs
<b>Cables for &lt;REFERENCE&gt;(XMI):</b>	17-01497-02 control/status cable, 34-pin connector 17-01446-01 bulk power cable 17-01525-01 remote sense cable 17-02522-01 H7242 inhibit cable (if VAX 6000 Model 300 or 400 system) +13.5V output cable, 2-pin connector (part of Ethernet cable 17-01496-01) +3.3V DC and return leads attached to XMI bus bar assembly
<b>Service From:</b>	Front and rear of cabinet, doors open
<b>Tools Required:</b>	Flat and Phillips screwdrivers, 5/16" nutdriver
<b>Diagnostics:</b>	Green LED lights when +3.3V output is within regulation

The H7242 power regulator develops two regulated DC outputs: +3.3V, used to power system logic load, and +13.5V, available for an Ethernet transceiver.

Each H7242 has one green LED that is visible from the rear of cabinet. The LED lights to indicate that the +3.3V output is properly regulated.

**NOTE:** *The green LED does not indicate the status of the +13.5V Ethernet output.*

The power regulator consists of a single printed circuit board mounted on a right-angle bracket. The bracket has guiding edges for use when inserting the regulator into the cabinet.



# 5.9 H7242 Power Regulator Removal and Replacement

**Remove or replace the H7242 power regulator from the rear of the cabinet.**

**WARNING:** *High voltages are present in the H7242 power regulator. After power has been removed, wait at least 2 minutes before working on the unit.*

Figure 5-9: H7242 Power Regulator Removal

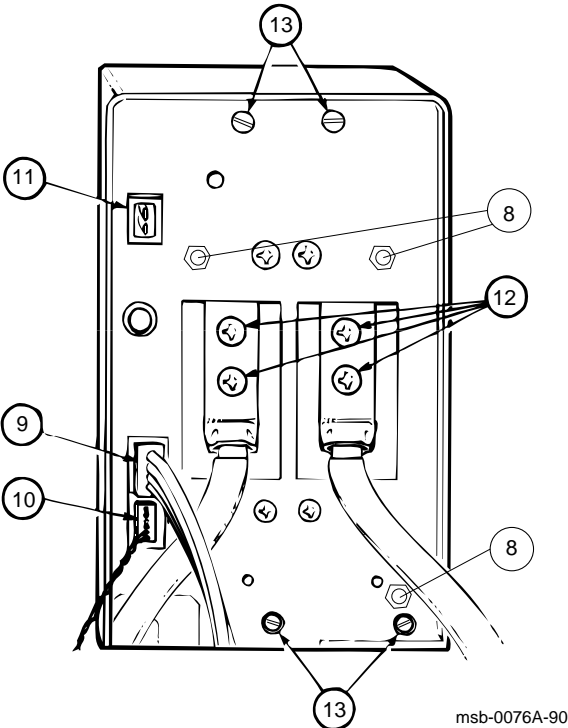

## REMOVAL

1. Perform an orderly shutdown of the system.
2. Turn the upper key switch on the front control panel to Off.
3. Pull the main circuit breaker on the AC power controller to Off.
4. Unplug system power cord; wait 2 minutes for capacitors to discharge.
5. Open the front and rear doors.
6. At the front of the cabinet, disconnect the bulk power cord by releasing the fastener clip and pulling. Disconnect cable 17-01446-01 from J3.
7. At front of cabinet, loosen one captive screw securing regulator.
8. At the rear of the cabinet, use a 5/16 inch nutdriver to remove the three nuts and the plastic cover. See ③ in Figure 5-9.
9. Disconnect the control/status cable. See ⑨. Disconnect cable 17-01497-02 from J1. Disconnect the H7242 inhibit cable (17-02522-01) (Models 300 and 400 only).
10. Disconnect the 17-01525-01 remote sense cable from J4. See ⑩.
11. Disconnect the +13.5V cord (part of 17-01496-01) from J2 (if Ethernet connection is present). See ⑪.
12. Disconnect the bus bar leads by removing the four screws. See ⑫. Work the bus bar leads down into the XMI service area.
13. Using a flat screwdriver, loosen the four slotted screws. See ⑬.
14. Support the bottom of the H7242 as you pull it from the cabinet.

## REPLACEMENT

- Reverse Steps 1 through 14 above.

**NOTE:** *Make sure the lugs connecting the bus bar leads do not contact the sheet metal bracket around the mounting points.*

*The H7242 ground reference wire is connected to the regulator's circuit board and return bus bar by a screw and washer. Make sure the wire is intact and properly connected. Tuck the wire out of the way when inserting the regulator into the system.*

# 5.10 H7206-B Power and Logic Unit

## 5.10.1 Specifications

The H7206-B power and logic unit is located in the lower right rear of the cabinet, just above the H405 AC power controller.

Figure 5-10: H7206-B Power and Logic Unit (Rear View)

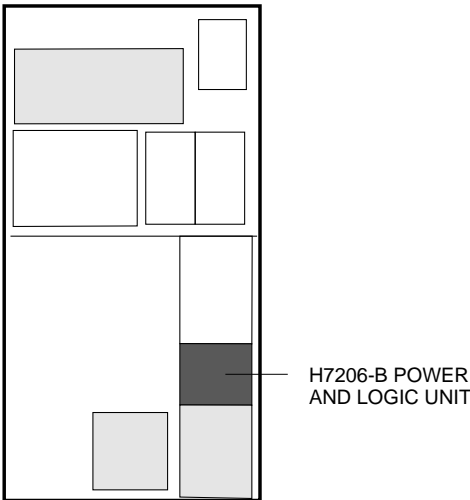

msb-0079A-90

**Table 5–8: H7206-B Power and Logic Unit Specifications**

<b>Parameter</b>	<b>Description</b>
<b>Part Number:</b>	H7206-B
<b>Location:</b>	Lower right rear of cabinet, just above the H405 AC power controller
<b>Dimensions:</b>	5" H x 5" W x 20.5" D
<b>Weight:</b>	13 lbs
<b>Cables:</b>	17-01498-01 to XTC module 17-02475-01 H7206-B J6 to H7206-B bezel 17-02494-01 H7206-B J12 to H7206-B bezel 17-02500-01 H7206-B to XMI 17-01569-01 DWMBB/B to H7206-B power OK signals 17-01666-01 control/status to regulators on VAXBI side 17-01497-02 control/status to regulators on XMI side 17-01447-01 bulk power to regulators on VAXBI side 17-01446-01 bulk power to regulators on XMI side 17-01570-01 power to front and rear blowers 17-01501-01 input from AC power controller 17-02485-01 to optional battery backup unit 17-02975-01 to optional battery backup unit
<b>Service From:</b>	Rear of cabinet, door open
<b>Tools Required:</b>	Flat and small Phillips screwdrivers
<b>Diagnostics:</b>	AC input and power regulator indicator lights will light

The H7206-B power and logic unit contains the fan/power and logic modules.

The fan/power module functions are:

- AC to 300V DC conversion
- 24V DC to blowers
- Control panel key switch interface

The logic module functions are:

- AC OK and DC OK control for system
- Battery backup unit control logic
- Door interlock logic
- DEC power bus logic

### **5.10.2 H7206-B Power and Logic Unit Switches and Indicators**

**The H7206-B power and logic unit has ten LEDs and one reset switch, visible from the front of the cabinet.**

**Figure 5–11: H7206-B Power and Logic Unit Switches and Indicators**

newart:msb0080b.ps

The power and logic unit consists of an AC to DC rectifier and filter, a fan/power module, and a logic module. The unit has ten indicator LEDs and one reset switch.

The nine LEDs in the upper right corner of the H7206-B are explained in Table 5–9. Refer to Figure 5–11 for LED numbering.

The green +14V bias LED lights to indicate when the bias supply on the fan/power module is working.

**WARNING:** *When the +14V bias LED is off, do not assume that the bulk supply is deenergized. This LED does not indicate the presence or absence of the 300V bulk supply.*

**Table 5–9: H7206-B LEDs**

LED	Color	Meaning
9	Red	Fault (airflow, interlock, overtemperature)
8	Red	XMI-1 module in XMI-2 card cage
7	Red	H7214 or H7242 installed incorrectly
6	Red	VAXBI—H7214 fault
5	Red	VAXBI—H7215 fault
4	Red	XMI—H7242 fault
3	Red	XMI—H7214 fault
2	Red	XMI—H7215 fault
1	Green	+14V logic bias is okay

LEDs 2 through 6 are latched on to indicate regulator faults. Reset these LEDs by turning the key switch to Off and back to Enable or Standby, or by pressing the reset switch (see Figure 5–11). LEDs 5 and 6 are always lit in Standby mode, since the VAXBI side is off in this key position.

The H7206-B LEDs may not indicate problems with regulators if the status cables are not correctly seated.

## 5.11 H7206-B Power and Logic Unit Removal and Replacement

Remove or replace the H7206-B power and logic unit using a flat screwdriver. The assembly is held in place by six hex screws. There are 11 cables. If you cannot disconnect some cables from the front of the cabinet, remove the plenum to access the connectors (see Section 6.7).

**WARNING:** *High voltages are present in the H7206-B power and logic unit. After power has been removed, wait at least 2 minutes before working on the unit.*

Figure 5–12: H7206-B Power and Logic Unit Removal (Top View)

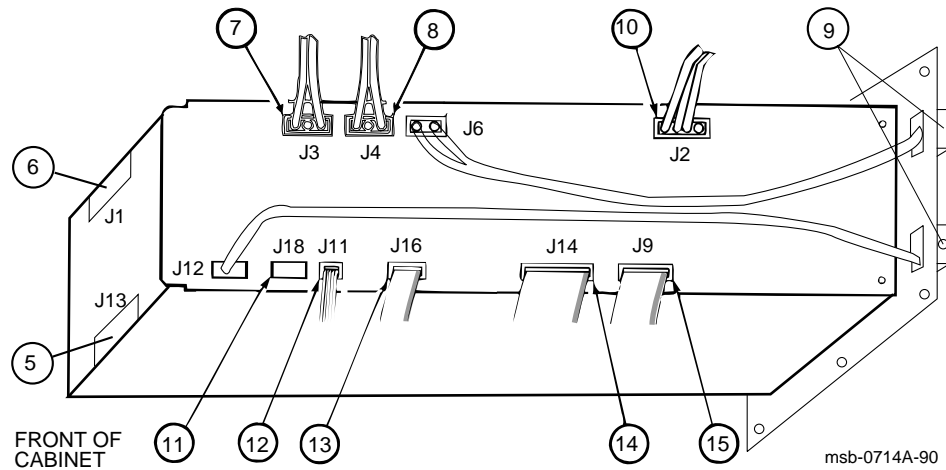

## REMOVAL

1. Perform an orderly shutdown of the system.
2. Turn the upper key switch on the front control panel to Off.
3. Pull the main circuit breaker on the AC power controller to Off. Unplug the system power cord. Wait 2 minutes for the capacitors to discharge.
4. Open the front and rear doors.
5. At the front of the cabinet, disconnect the 17-02759-01 cable from J13. See ⑤ in Figure 5–12.
6. Working from the front of the cabinet, disconnect the 17-01501-01 AC input cable from J1. See ⑥.
7. Disconnect the 17-01447-01 bulk power cable from J3. See ⑦.
8. Disconnect the 17-01446-01 bulk power cable from J4. See ⑧.
9. If the system has an H7236-A battery backup unit, disconnect the two cables (17-02475-01 and 17-02494-01) from the outside of the bezel. See ⑨.
10. Disconnect the 17-01570-01 blower cable from J2. See ⑩.
11. Disconnect the 17-02500-01 XMI cable from J18. See ⑪.
12. Disconnect the 17-01569-01 power OK signal cable from J11. See ⑫.
13. Disconnect the 17-01498-01 XTC cable from J16. See ⑬.
14. Disconnect the 17-01497-02 control/status cable from J14. See ⑭.
15. Disconnect the 17-01666-01 control/status cable from J9. See ⑮.
16. Working from the rear of the cabinet, use a flat screwdriver to remove the six hex screws from the bezel.
17. Slide the unit out of the cabinet. Be careful not to damage the cables on the top of the unit.

## REPLACEMENT

- Reverse Steps 1 through 17 above.
- When reinstalling the unit, make sure the locating tang on the front end of the unit engages the locating stud on the front shelf.



# 5.12 H7206-B Fan Removal and Replacement

Remove the H7206-B power and logic unit's top cover to access the fan (part number 12-24701-06). There are eight screws and one cable. Use a small Phillips screwdriver to remove the fan.

Figure 5-13: H7206-B Fan Removal

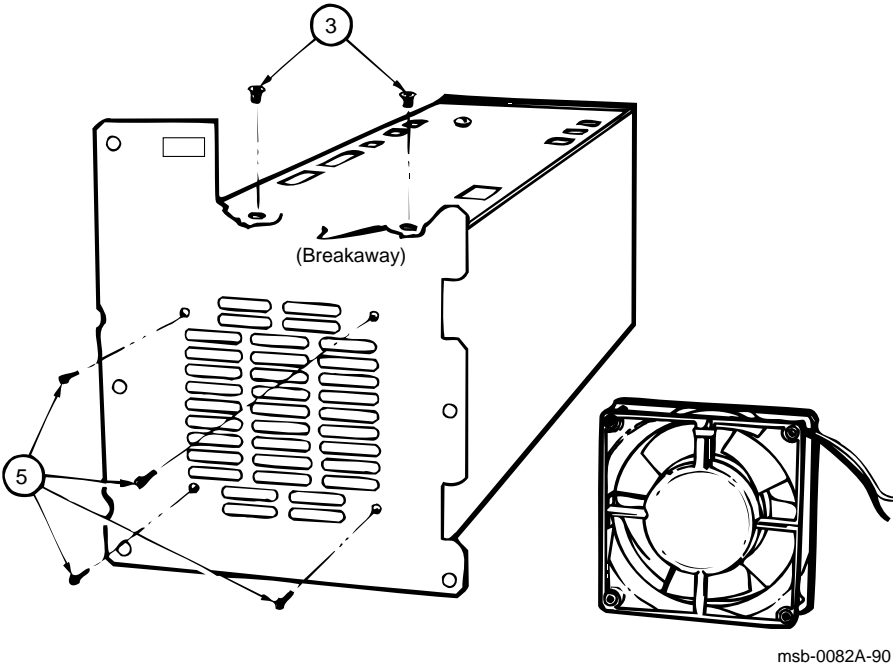

msb-0082A-90

## REMOVAL

1. Remove the power and logic unit from the cabinet (see Section 5.11).
2. Disconnect the cables from J6 and J12 (see Figure 5-12) and remove the connectors from the rear bezel (use a 3/16 inch nutdriver).
3. Using a Phillips screwdriver, remove the top cover by removing two screws on the top (see ❸ in Figure 5-13) and two screws in the back.
4. Disconnect the fan cable from J8 on the power/fan module by pulling out the 2-pin connector.
5. Using a small Phillips screwdriver, remove the four screws that attach the fan to the rear panel of the power and logic unit. See ❹.
6. Remove the fan.

## REPLACEMENT

- Reverse Steps 1 through 6 above.

The fan is powered by the same +24V DC used to run the main system blowers. There is no fault indication if the fan stops.

When the cabinet doors are open, the power and logic unit depends entirely on its internal fan for cooling. When working on the system, look at the fan to see if it is operating.

### 5.13 H405 AC Power Controller

**The H405 AC power controller is located in the lower right rear of the cabinet. The assembly comes in two models: the H405-E for 60 Hz systems and the H405-F for 50 Hz systems.**

Figure 5-14: H405 AC Power Controller (Rear View)

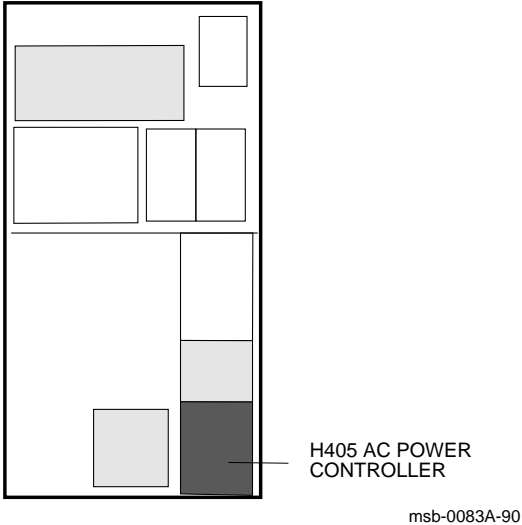

**Table 5–10: H405 AC Power Controller Specifications**

<b>Parameter</b>	<b>Description</b>
<b>Part Number:</b>	H405-E (60 Hz) H405-F (50 Hz)
<b>Location:</b>	Lower right rear corner of cabinet
<b>Dimensions:</b>	12.0 in. H x 7.5 in. W x 15 in. D
<b>Weight:</b>	34 lbs
<b>Cables:</b>	17-01501-01 AC input to power and logic unit 17-02759-01 DEC power bus to H7206-B power and logic unit 17-01815-01 to 50 Hz transformer 17-01844-01 to temperature sensor 17-00442-27 to optional battery backup unit
<b>Service From:</b>	Rear of cabinet, door open
<b>Tools Required:</b>	Large Phillips and flat screwdrivers

In 60 Hz systems, the H405-E AC power controller routes 3-phase, 208V AC power to the output connector J2, used to connect power to the H7206-B power and logic unit. For 50 Hz systems, the same output is first routed to the transformer (part number 16-28393-01) which lowers the phase voltages to the required input range of the H7206-B.

The H405 AC power controller monitors the state of the cabinet thermostat mounted at the top of the cabinet. The thermostat is a normally closed thermal switch. The H405 also monitors the sense switch in the main circuit breaker. The sense switch is normally closed when the circuit breaker is in the On position.

If the thermal switch opens (overtemperature condition) or the sense switch opens (main circuit breaker is Off), the H405 removes power from the cabinet by opening an internal AC contactor. The battery backup unit, if present, is disabled by the Fail Safe Enable signal from delivering its 250V DC source to the H7206-B power and logic unit.

## 5.14 H405 AC Power Controller Removal and Replacement

Working mainly from the rear of the cabinet, remove or replace the H405 AC power controller using a large Phillips screwdriver. The assembly has six captive screws and seven cables.

Figure 5-15: H405 AC Power Controller Removal

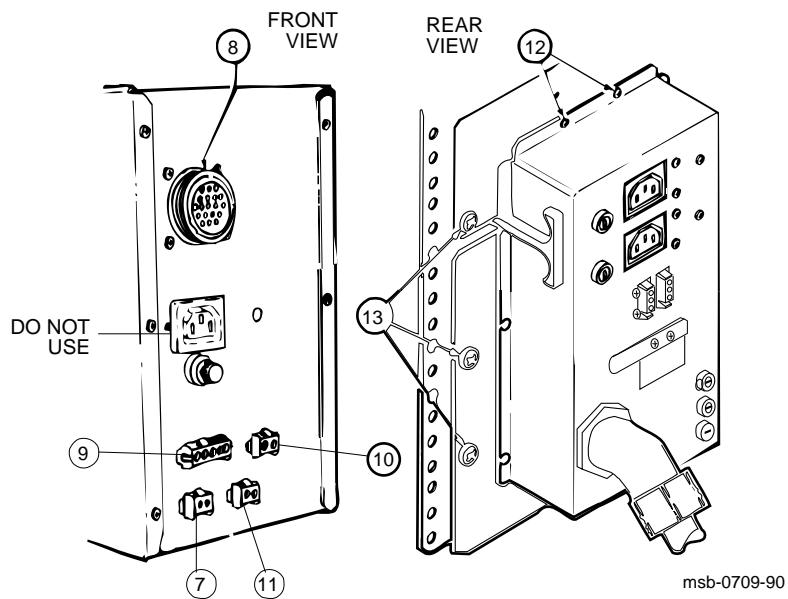

**WARNING:** *The H405 AC power controller is heavy. Exercise caution when lifting and moving this unit.*

## REMOVAL

1. Perform an orderly shutdown of the system.
2. Turn the upper key switch on the front control panel to Off.
3. Pull the main circuit breaker on the AC power controller to Off.
4. Unplug the system power cord.
5. Open the front and rear doors.
6. Wait 2 minutes for the capacitors to discharge.
7. Working from the front of the cabinet, disconnect the 17-01549-01 fail safe enable cable from J6. See ⑦ in Figure 5–15.
8. Disconnect the 17-01501-01 AC input cable from J2 by twisting the black connector ring counterclockwise. If the system has a 50 Hz transformer, disconnect the 17-01815-01 cable from J2. See ⑧.
9. Disconnect the 17-02759-01 DEC power bus cable from J1. See ⑨.
10. Disconnect the 17-01844-01 temperature sensor cable from J9. See ⑩.
11. Disconnect 17-02521-01 from J7. See ⑪.
12. At the rear of the cabinet, use a flat screwdriver to remove the two hex screws at the top of the subassembly. See ⑫.
13. Using a large Phillips screwdriver, remove the six screws that hold the AC power controller in place. See ⑬.
14. Pull the AC power controller toward you and remove it.

## REPLACEMENT

- Reverse Steps 1 through 14 above.

**NOTE:** *Route the 17-01844-01 and 17-01549-01 cables away from the transformer (50 Hz systems only).*

## 5.15 50 Hz Transformer

**A transformer is required for 50 Hz systems. The transformer is located on the floor of the cabinet, directly below the power and logic unit.**

Figure 5-16: 50 Hz Transformer (Front View)

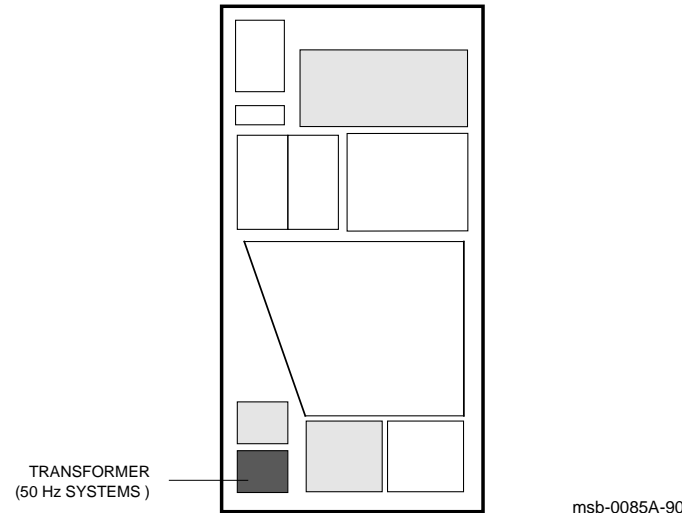

**Table 5–11: 50 Hz Transformer Specifications**

<b>Parameter</b>	<b>Description</b>
<b>Part Number:</b>	16-28393-01
<b>Location:</b>	Lower left front of cabinet
<b>Dimensions:</b>	6.5" H x 6" W x 10" D
<b>Weight:</b>	40 lbs
<b>Cables:</b>	18-01815-01 to H405-F AC power controller 17-01501-01 to H7206-B power and logic unit
<b>Service From:</b>	Front of cabinet, door open
<b>Tools Required:</b>	Flat screwdriver Phillips screwdriver



# 5.16 50 Hz Transformer Removal and Replacement

**Working from the front of the cabinet, remove the transformer using a flat screwdriver. The transformer has six screws and two power cables.**

Figure 5-17: 50 Hz Transformer Removal

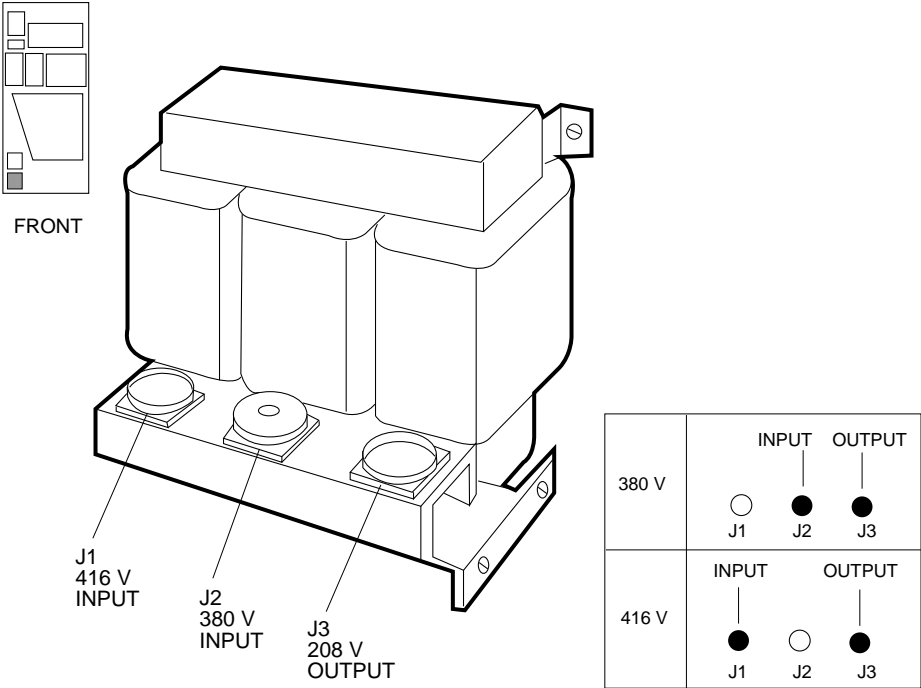

msb-0035A-90

**WARNING:** *To avoid high voltage shock, a round, threaded cap is provided to cover the unused inlet connector. When replacing, rewiring, or reconnecting the transformer, make sure the cap is properly installed. The cap fits onto either the 380V (J2) or the 416V (J1) inlet connector.*

**WARNING:** *The 50 Hz transformer is heavy. Exercise caution when lifting and moving this unit.*

## **REMOVAL**

1. Perform an orderly shutdown of the system.
2. Turn the upper key switch on the front control panel to Off.
3. Pull the main circuit breaker on the AC power controller to Off.
4. Unplug the system power cord.
5. Wait 2 minutes for the capacitors to discharge.
6. Open the front door.
7. Use a Phillips screwdriver to remove the six #10-32 screws securing the sheet metal panel. This panel is located below the power and logic unit.
8. Disconnect the 17-01815-01 power input cable from J1 (416V) or J2 (380V). See Figure 5-17.
9. Disconnect the 17-01501-01 power output cable from J3.
10. Remove the six screws that attach the transformer to the cabinet rails.
11. Remove the transformer.

## **REPLACEMENT**

- Reverse Steps 1 through 10 above.

# 5.17 H7236-A Battery Backup Unit

**The optional H7236-A battery backup unit supplies power to the system upon power failure. It is located in the bottom of the cabinet.**

**Figure 5-18: H7236-A Battery Backup Unit (Front View)**

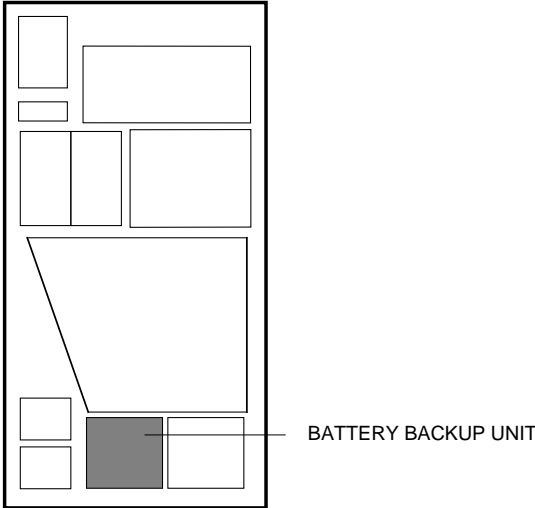

msb-0400-89

**Table 5–12: H7236-A Battery Backup Unit Specifications**

<b>Parameter</b>	<b>Description</b>
<b>Part Number:</b>	H7236-A
<b>Location:</b>	Bottom center of cabinet
<b>Dimensions:</b>	10.5" H x 8.75" W x 28.0" D
<b>Weight:</b>	98 lbs
<b>Cables:</b>	17-00442-27 J2 to H405 17-02485-01 BBU to H7206-B 300V 17-02975-01 BBU to H7206-B signal
<b>Service From:</b>	Front and rear of cabinet, doors open
<b>Tools Required:</b>	Phillips screwdriver

When the system detects a power failure, it signals the H7236-A battery backup unit (BBU). If the power failure lasts less than one second, the BBU's ride-through capability enables the system to function as if nothing has happened. (Disk drives located in the bottom of the cabinet, however, are shut down upon detection of the power failure.)

If the power failure lasts longer than one second, Power Fail Interrupt is signaled and the following actions are initiated:

- The H7236-A supplies full power to the XMI card cage for at least 500 milliseconds while the processors write their cache data back to memory.
- If the system has a VAXBI bus, the operating system stores all current VAXBI processes during the same 500 millisecond period. Power to the VAXBI card cage is then disabled.
- The operating system stops.
- The H7236-A continues to power the XMI card cage so memory is refreshed and data is held.

If system power returns within 10 minutes, a warm restart is performed. The operating system continues from the point at which it stopped.

If the power outage is longer than 10 minutes, the H7236-A shuts off to prevent the battery from draining. Memory data is lost, since memory is cleared when power is restored.

## 5.18 H7236-A Battery Backup Unit Removal and Replacement

The H7236-A battery backup unit has three FRUs: the fan, the battery pack, and the enclosure.

### 5.18.1 Fan Removal and Replacement

The fan and fan panel are removed and replaced as a unit.

Figure 5–19: H7236-A Battery Backup Unit (Rear View)

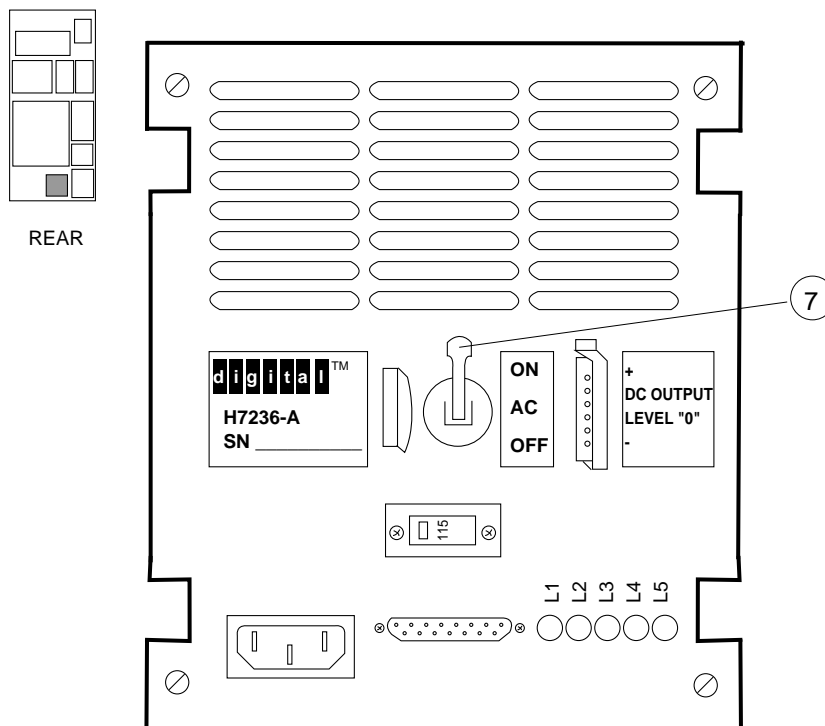

msb-0729A-90

## REMOVAL

1. Perform an orderly shutdown of the system.
2. Turn the upper key switch on the front control panel to Off.
3. Pull the main circuit breaker on the AC power controller to Off.
4. Unplug the system power cord.
5. Wait 2 minutes for the capacitors to discharge.
6. Open the front and rear doors.
7. Turn the H7236-A power switch to Off. See ⑦ in Figure 5–19.
8. Use a Phillips screwdriver to remove the four corner screws from the fan panel. See ⑧ in Figure 5–20.
9. Disconnect the 2-pin connector from the electronics module. See ⑨.
10. Disconnect the ground wire from the fan panel. See ⑩.

## REPLACEMENT

- Reverse Steps 1 through 10 above.

Figure 5–20: H7236-A BBU Fan Removal

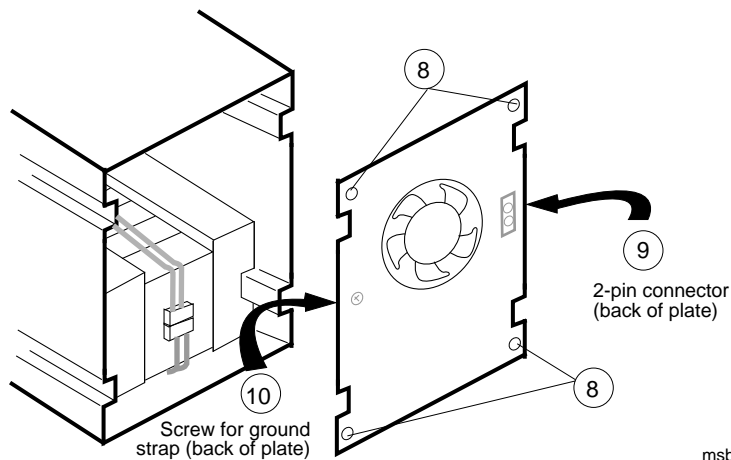

### 5.18.2 Battery Pack Removal

**The battery pack weighs 45 pounds. Support the bottom of the pack when moving it in or out of the enclosure to prevent it from binding.**

Figure 5–21: H7236-A BBU Battery Pack Removal

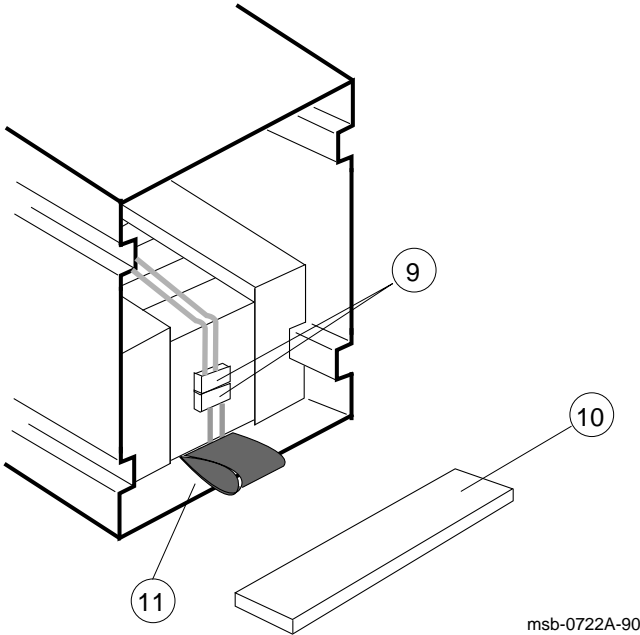

msb-0722A-90

1. Perform an orderly shutdown of the system.
2. Turn the upper key switch on the front control panel to Off.
3. Pull the main circuit breaker on the AC power controller to Off.
4. Unplug the system power cord.
5. Wait 2 minutes for the capacitors to discharge.
6. Open the front and rear doors.
7. Turn the H7236-A power switch to Off. See ⑦ in Figure 5–19.
8. Remove the fan. See Section 5.18.1.
9. Disconnect the battery power connector. See ⑨ in Figure 5–21. Disconnecting and connecting the two parts of this connector requires a great deal of force.
10. Remove the spacer. See ⑩.
11. Using the pull tab, pull the battery pack straight out. See ⑪. The battery pack weighs 45 pounds. Support the bottom of the pack when moving it to ensure that it does not bind. Exercise caution when lifting and moving this unit.



### 5.18.3 Battery Pack Replacement

**When you replace the battery pack, press the new battery reset button only if the battery pack is new.**

Figure 5-22: H7236-A Battery Backup Unit (Front View)

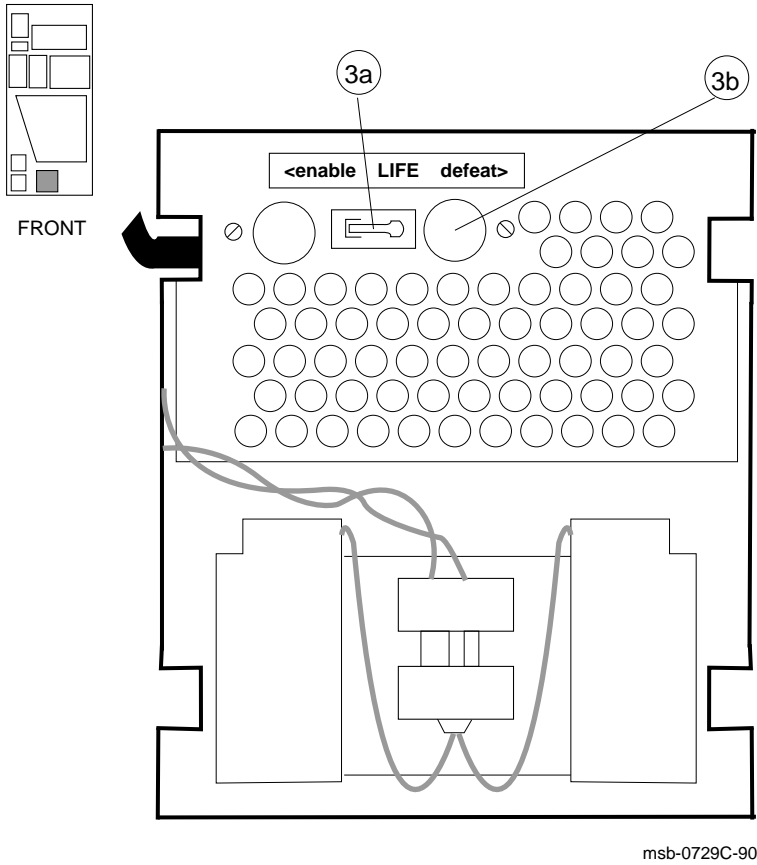

1. From the front of the cabinet, slide the replacement battery pack into the enclosure. Support the bottom of the pack to prevent it from binding.
2. If you are replacing the battery pack you removed in Section 5.18.2, go to Step 4.
3. If you are installing a new battery pack, do the following (see ③ in Figure 5-22):
  - a. Set the battery life switch to enable.
  - b. Press the new battery reset button.

**NOTE:** *The new battery reset button resets the battery aging information in the EEPROM. Press this button **only** when you are replacing the battery pack with a new one. The battery life switch must be in the Enable position for this button to function.*

4. Reverse Steps 1 through 10 in Section 5.18.2.

### 5.18.4 Enclosure Removal and Replacement

**You must remove the battery pack before removing or replacing the enclosure. The enclosure will slide free of the cabinet only if the battery pack is first removed.**

Figure 5-23: H7236-A BBU Enclosure Removal

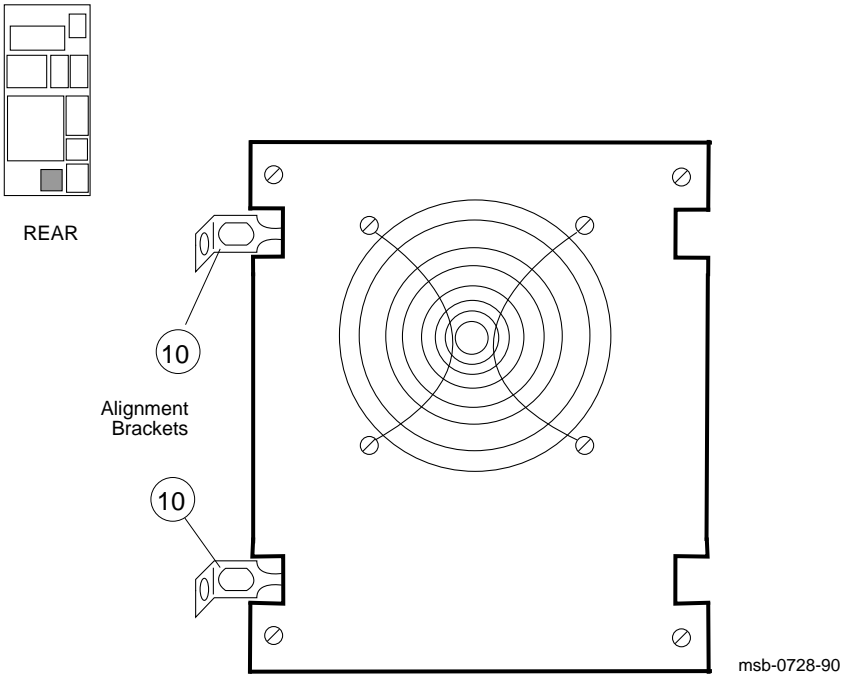

## **REMOVAL**

1. Perform an orderly shutdown of the system.
2. Turn the upper key switch on the front control panel to Off.
3. Pull the main circuit breaker on the AC power controller to Off.
4. Unplug the system power cord.
5. Wait 2 minutes for the capacitors to discharge.
6. Open the front and rear doors.
7. Turn the H7236-A power switch to Off. See Figure 5–19.
8. Remove the fan. See Section 5.18.1.
9. Remove the battery pack. See Section 5.18.2.
10. Use a Phillips screwdriver to remove the alignment brackets. See ⑩ in Figure 5–23. Each right-angle alignment bracket has two screws. Remove the screws that hold the brackets to the enclosure first.
11. Remove the cable connectors at the rear of the enclosure. See Figure 5–19.
12. Push the enclosure forward from the rear of the cabinet.

## **REPLACEMENT**

- Reverse Steps 1 through 12 above.

## Chapter 6

# Cabinet and Airflow Subsystem

---

This chapter describes the field-replaceable units of the cabinet and units that monitor and control the interior environment of the cabinet. Sections include:

- Door and Filter Removal and Replacement (Front)
- Door and Filter Removal and Replacement (Rear)
- Airflow Sensor Removal and Replacement
- Temperature Sensor Removal and Replacement
- Blower Assembly Specifications
- Blower Assembly, Front and Rear
- Blower Assembly Removal and Replacement
- Side Panel Removal

# 6.1 Door and Filter Removal and Replacement (Front)

Both the front and rear doors have air filters that need to be replaced periodically. Figure 6-1 shows the inside of the front door.

Figure 6-1: Front Door (Inside View)

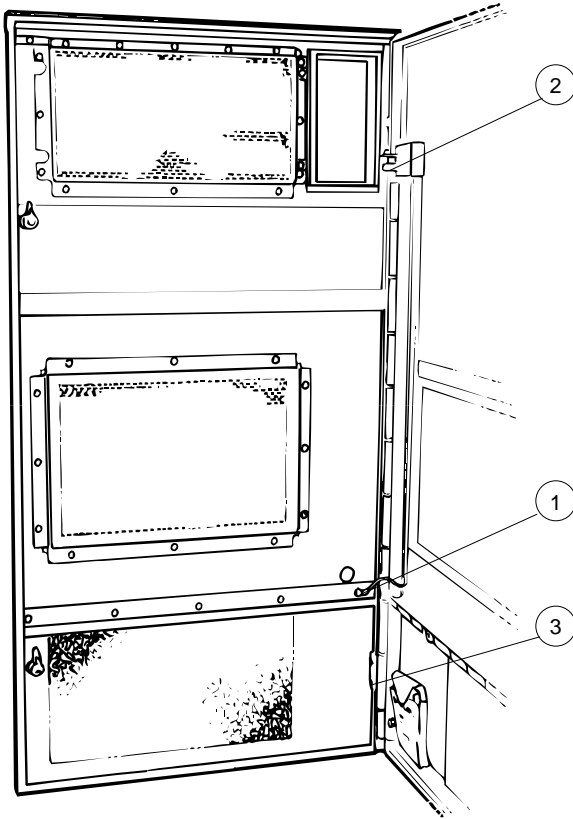

msb-0092A-90

**Table 6–1: Front Cabinet Door and Air Filter Specifications**

<b>Parameter</b>	<b>Description</b>
<b>Front Door:</b>	70-24623-01
<b>Dimensions:</b>	28.25" W x 56" D
<b>Weight:</b>	31 lbs
<b>Air Filters:</b>	12-11255-23 — 17.5" W x 9" D 12-11255-24 — 18.5" W x 12.5" D (air intake) 12-11255-25 — 18.5" W x 10" D
<b>Tools Required:</b>	3/8" and 11/32" nutdrivers

### **REMOVAL OF DOORS**

1. Remove the ground strap, which is attached to the front door, using a 3/8 inch nutdriver. See ❶ in Figure 6–1.
2. Pull up the pin in the top hinge and lock in place. See ❷.
3. Pull up and hold the pin in the bottom hinge as you lift the door up to remove it from the cabinet. See ❸.

### **REPLACEMENT OF DOORS**

1. Put the door into position at the hinges and then release the lock holding the top pin.
2. Pull up the bottom pin and release it to secure the door.

### **REMOVAL AND REPLACEMENT OF AIR FILTERS**

It is especially important that the filters in the center of the front door and at the bottom of the rear door be clean. These filters cover the air intake area.

Three filters are covered with a grill that must be removed to replace the air filter.

1. Use an 11/32 inch nutdriver to remove the grill.
2. Pull off the old filter and stick on the new one.
3. Reinstall the grills (they protect against electromagnetic interference).

## 6.2 Door and Filter Removal and Replacement (Rear)

Figure 6-2 shows the inside of the rear door.

Figure 6-2: Rear Door (Inside View)

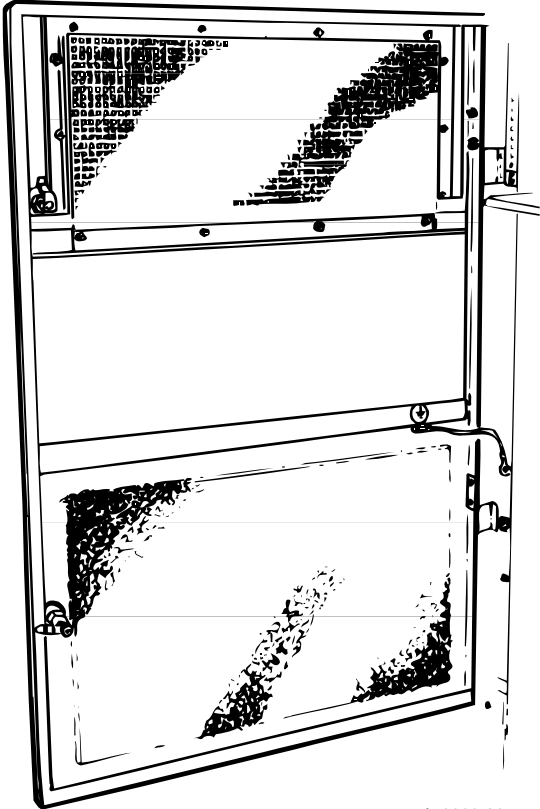

msb-0093-89



**Table 6–2: Rear Cabinet Door and Air Filter Specifications**

<b>Parameter</b>	<b>Description</b>
<b>Rear Door:</b>	70-24124-01
<b>Dimensions:</b>	28" W x 41.5" D
<b>Weight:</b>	20 lbs
<b>Air Filters:</b>	12-11255-17 — 26" W x 15.5" D (air intake) 12-11255-22 — 22" W x 9.5" D
<b>Tools Required:</b>	3/8" and 11/32" nutdrivers

The rear cabinet door has a pocket for system information.

For the removal and replacement procedures for the rear door and filters, see Section 6.1.

## 6.3 Airflow Sensor Removal and Replacement

The airflow sensor is mounted inside the cabinet above the XMI power regulators, to the left of the temperature sensor. The airflow sensor regulates the two blowers and shuts down the power regulators if the airflow in the cabinet is inadequate.

Figure 6-3: Airflow Sensor (Front View)

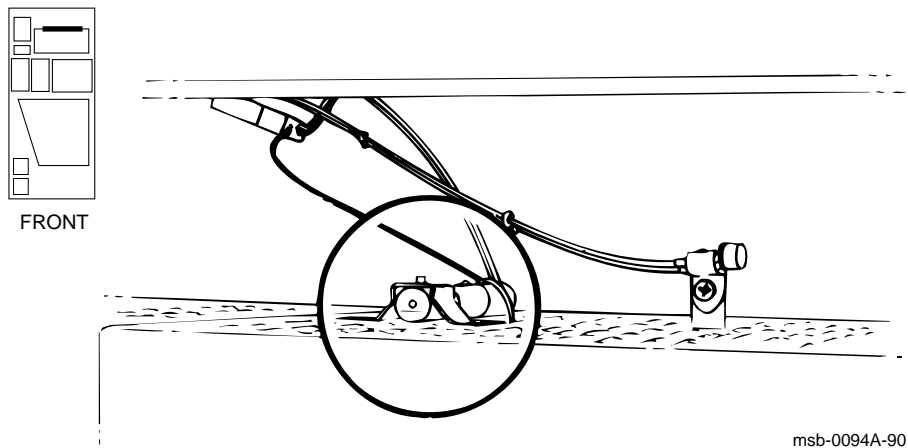

Table 6-3: Airflow Sensor Specifications

Parameter	Description
<b>Part Number:</b>	12-25024-11
<b>Location:</b>	From the front, the sensor is above the outlet grill of the XMI power regulators and to the left of the temperature sensor.
<b>Signal Cable:</b>	17-01570-01, to both blowers and to the H7206-B power and logic unit
<b>Power:</b>	+24V (common to main blowers)
<b>Service From:</b>	Front of the cabinet, doors open
<b>Tools Required:</b>	Large and small Phillips screwdrivers, wire clipper

## **OPERATION**

If the airflow sensor detects inadequate airflow, it signals the H7206-B power and logic unit. After 30 seconds the H7206-B unit asserts the Interlock Inhibit signals to the XMI and VAXBI power regulators, which disable the regulators. Red LED number 9 on the H7206-B unit lights. (See Section 5.10.2.) The AC power is not affected.

Turn the system off at the control panel as you investigate the cause of the problem. To restart the system, use the front control panel.

## **REMOVAL**

1. Perform an orderly shutdown of the system.
2. Turn the upper key switch on the front control panel to Off.
3. Pull the main circuit breaker on the AC power controller to Off.
4. Unplug the system power cord.
5. Wait 2 minutes for the capacitors to discharge.
6. Open the front and rear doors.
7. Unplug at the connector.
8. Clip and remove the tiewrap around the sensor.
9. Push down on top of the metal bracket to pop out one side so that you can remove the sensor. Leave the bracket in the grillwork or mark the exact location so that the new sensor is placed in the same spot.

## **REPLACEMENT**

1. Slip the new sensor in under the bracket and push the end of the bracket back into the grill.
2. Secure in place with a tiewrap (90-07031-00).
3. Reattach at the connector.
4. Reverse Steps 1 through 6 in the Removal section above.

## 6.4 Temperature Sensor Removal and Replacement

**The temperature sensor is mounted inside the cabinet above the XMI power regulators, to the right of the airflow sensor. When the system overheats, the sensor signals the H405 AC power controller to shut down the system.**

**CAUTION:** *The leads on the temperature sensor are weak and will break if not handled properly.*

Figure 6-4: Temperature Sensor (Front View)

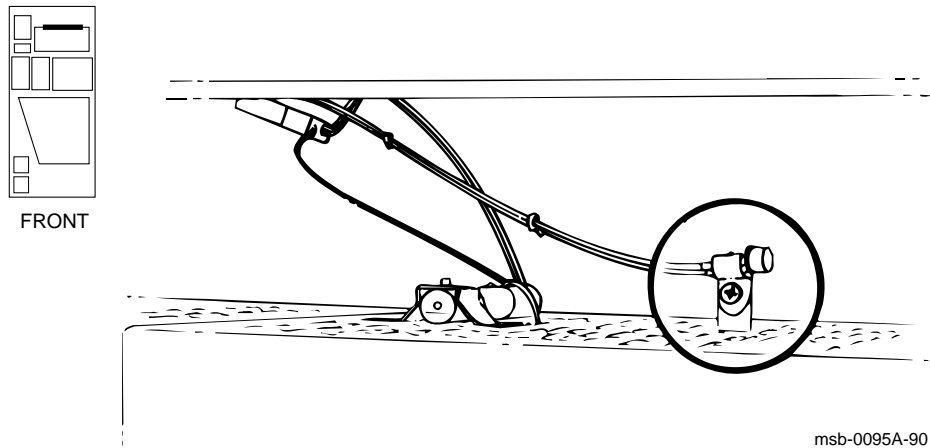

**Table 6–4: Temperature Sensor Specifications**

<b>Parameter</b>	<b>Description</b>
<b>Part Number:</b>	17-01844-01, sensor and cable to J9 on the H405 power controller
<b>Location:</b>	From the front, the sensor is above the outlet grill of the XMI power regulators and to the right of the airflow sensor.
<b>Power:</b>	H405 power controller
<b>Threshold:</b>	75°C (167°F)
<b>Service From:</b>	Inside the rear door
<b>Tools Required:</b>	Small Phillips screwdriver

### **OPERATION**

When the temperature sensor reaches its threshold, it signals the H405 AC power controller to cut off all power. When the sensor cools down, the power is restored automatically.

### **REMOVAL**

The temperature sensor is permanently attached to the cable that goes to the power controller.

To remove a temperature sensor:

1. Perform an orderly shutdown of the system.
2. Turn the upper key switch on the front control panel to Off.
3. Pull the main circuit breaker on the AC power controller to Off and unplug the system power cord.
4. Wait 2 minutes for the capacitors to discharge.
5. Open the front and rear doors.
6. Unplug the cable at J9 on the H405 power controller.
7. Pull the cable up through the system.
8. With a Phillips screwdriver remove the screw from the bracket that holds the sensor.

### **REPLACEMENT**

Install the new sensor in the same place. Reverse Steps 1 through 8 above.

# 6.5 Blower Assembly Specifications

Two blowers are located in the center of the cabinet, just below the XMI and VAXBI card cages. The mounting plate with the four captive screws is part of the blower assembly (12-27848-01).

Figure 6-5: Blower Assembly

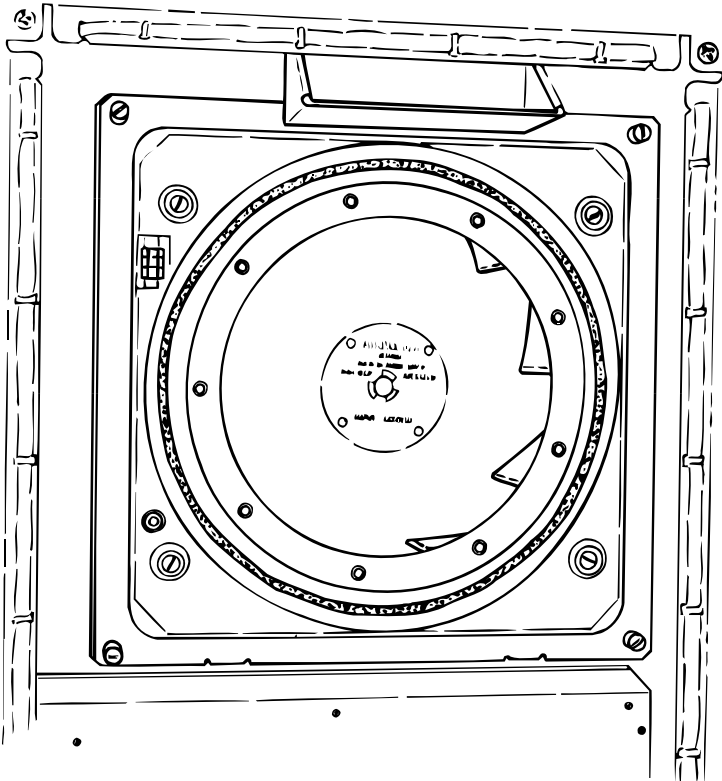

msb-0096-89

**Table 6–5: Blower Assembly Specifications**

<b>Parameter</b>	<b>Description</b>
<b>Part Number:</b>	12-27848-01; two used
<b>Location:</b>	Front and rear of the lower cabinet area
<b>Dimensions:</b>	15" x 15"
<b>Weight:</b>	9 lbs
<b>Power:</b>	+24V
<b>Signal Cable:</b>	17-01570-01, to the H7206-B power and logic unit and to the airflow sensor
<b>Service From:</b>	Front and rear of cabinet, doors open
<b>Tools Required:</b>	Large Phillips and 1/4" flat screwdrivers

Each system has two blowers to provide the required airflow within the cabinet. If the airflow sensor detects inadequate airflow, it signals the H7206-B power and logic unit. After 30 seconds the H7206-B unit asserts the Interlock Inhibit signals to the XMI and VAXBI power regulators, which disable the regulators. Red LED number 9 on the H7206-B unit lights. (See Section 5.10.2.) The AC power is not affected.

## 6.6 Blower Assembly, Front and Rear

Figure 6-6 and Figure 6-7 show the two blowers, each with their protective grillwork in place. Although the mounting of the two units is somewhat different, once you remove the protective grillwork from the rear blower assembly the same removal procedures apply to both blowers.

Figure 6-6: Front Blower

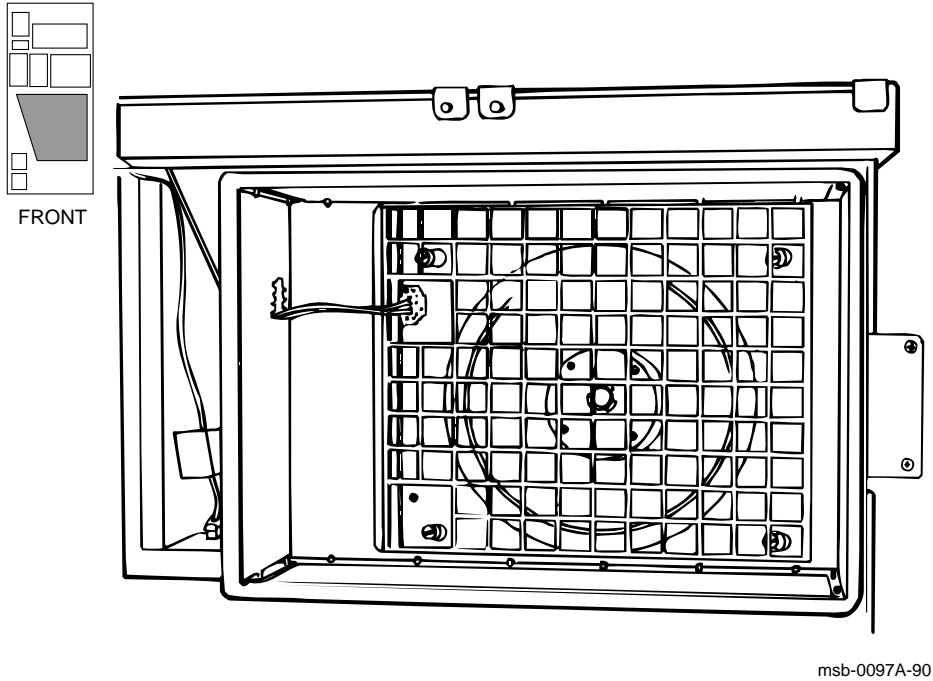
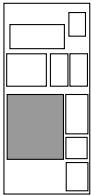
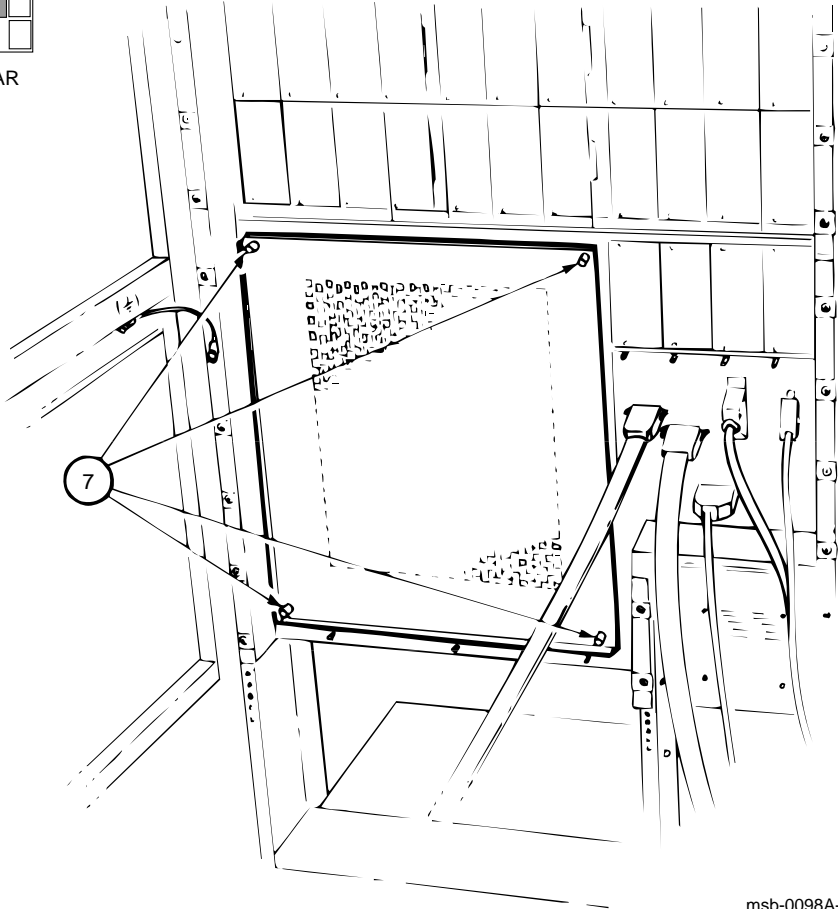



Figure 6-7: Rear Blower



REAR



msb-0098A-90

# 6.7 Blower Assembly Removal and Replacement

To remove the rear blower, you must first remove the protective grillwork. You do not need to remove the grillwork from the front blower, as it can be lifted off with the plenum.

Figure 6-8: Blower Assembly Removal (Rear View)

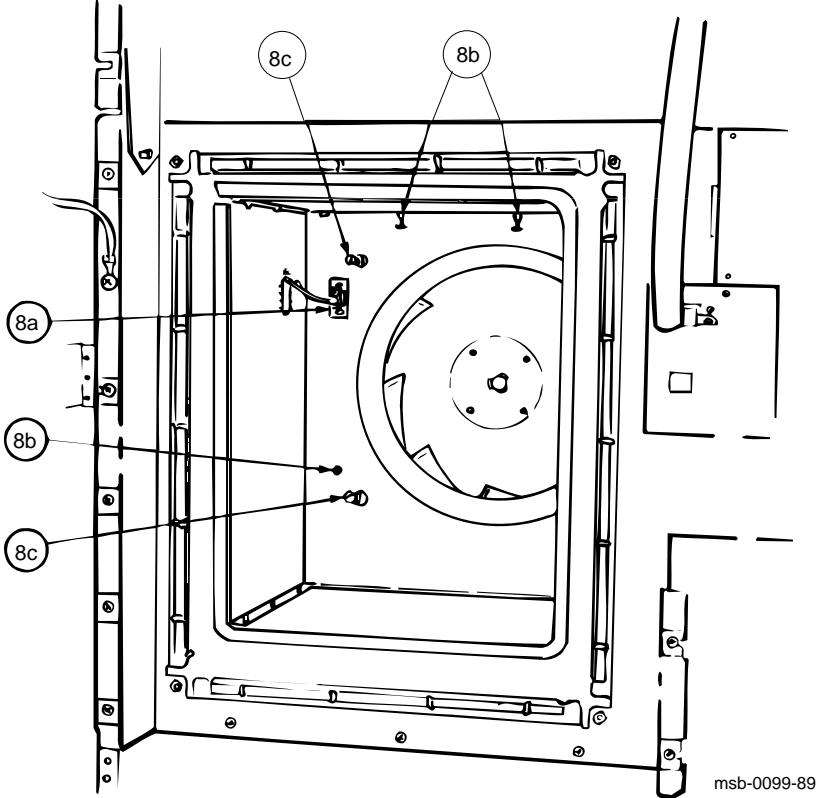

## **REMOVAL**

1. Perform an orderly shutdown of the system.
2. Turn the upper key switch on the front control panel to Off.
3. Pull the circuit breaker on the AC power controller to Off.
4. Unplug the system power cord.
5. Wait 2 minutes for the capacitors to discharge.
6. Open the front or rear door to access the blower to be replaced.
7. Loosen the four captive screws and lift off the metal grill in front of the rear blower. See ⑦ in Figure 6-7. Figure 6-8 shows the rear blower with the metal grill removed.
8. Lift the plenum away from the blower (see ⑧ in Figure 6-8):
  - a. Unplug the power cord and push it through the hole on the left panel.
  - b. Remove the two #10-32 screws inside the top panel and one screw at the left on the panel at the back of the plenum.
  - c. Shift the plenum to the left and lift it off from the four screws.

## **REPLACEMENT**

To replace the blower, reverse the steps above. Note the blower has two metal tabs at the bottom that slide into slots in the cabinet.

# 6.8 Side Panel Removal

The right side panel of the system cabinet is detachable, so the cabinet can be bolted to an expander cabinet.

Figure 6-9: Side Panel Removal (Front View)

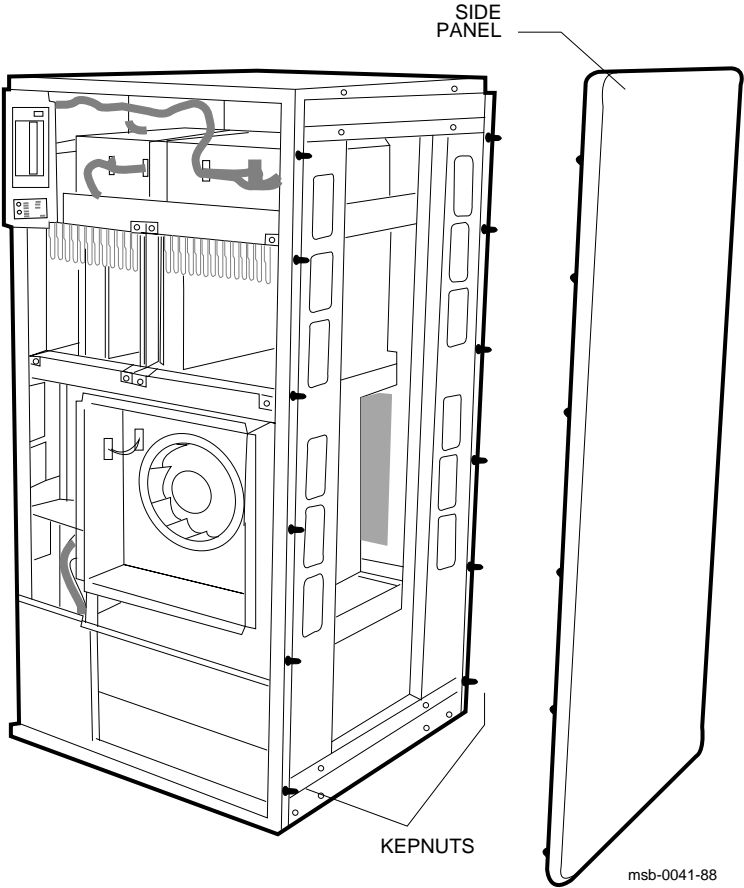

**Table 6–6: Side Panel Specifications**

<b>Parameter</b>	<b>Description</b>
<b>Part Number:</b>	70-19485-00
<b>Location:</b>	From the front, the panel on the right side is removable.
<b>Dimensions:</b>	30" W x 57" H x 3/4" D
<b>Weight:</b>	34.25 lbs
<b>Service From:</b>	Right side of cabinet, as viewed from the front
<b>Tools Required:</b>	7/16" socket wrench

For most configurations, expansion will be to the right of the system cabinet. To prepare for expansion, remove the side panel of the system cabinet as follows:

1. Open the front and rear doors of the system cabinet and remove the doors by lifting them off their hinges.
2. Using a 7/16 inch socket wrench, remove the system cabinet's side panel by removing the 12 kepnuts (see Figure 6–9). Carefully lift the panel when removing it so as not to damage the threaded bolts. Do not remove the bolts.
3. Before attaching another cabinet, make sure the braided RFI shielding and securing clips are not damaged or missing. Check that any flexible spring-strip type RFI gaskets are present in all the mounting holes.

The <REFERENCE>(VAX\_XXXX) *Series Installation Guide* describes how to attach the system cabinet to a VAXBI expander cabinet.

## Appendix A

# Cable List

---

The following table lists the replaceable cables in the system.

**Table A–1: Cable List**

Part Number	Qty	Description
17-00442-27	1	H405 to H7236-A BBU
17-01038-01	1	Flexible backplane extension for VAXBI
17-01149-01	1	Firmware console-enable jumper for DEBNI module
17-01375-04	2	15' DWMBB/A to DWMBB/B connector, for VAXBI expander cabinet
17-01445-01	1	Power to logic board internal to H7206-B
17-01446-01	1	H7206-B to three regulators' jumps (XMI side)
17-01447-01	1	H7206-B to two regulators' jumps (VAXBI side)
17-01458-02	1	VAXBI ground strap
17-01496-01	1	VAXBI to Ethernet port and H7214
17-01497-02	1	H7206-B to <REFERENCE>(XMI) H7215 and H7214, 72 in. long
17-01498-01	1	XTC to H7206-B signal, 14-pin
17-01501-01	1	H405 to 50 Hz transformer
17-01523-01	1	H7215 regulator to VAXBIs $\pm 12V$
17-01525-01	3	H7214 regulator to bus bars (+5V remote sense)
17-01566-01	1	H7215 regulator to the XMI
17-01567-01	1	XTC to console port, 10-pin ribbon
17-01568-02	1	<REFERENCE>(XMI) to XTC (XTC power) 20-pin ribbon, 56 in. long

**Table A-1 (Cont.): Cable List**

<b>Part Number</b>	<b>Qty</b>	<b>Description</b>
17-01569-01	1	DWMBB/B to H7206-B power OK signals
17-01570-01	1	H7206-B to both blowers and airflow sensor
17-01661-01	3	Jumper assembly (on H7214 regulator output)
17-01662-01	1	<REFERENCE>(XMI) ground strap
17-01666-01	1	H7206-B to VAXBI regulators' signal, 60 in. long
17-01815-01	2	H405 to transformer cable (240V systems only)
17-01816-01	1	XTC to system control assembly 20- to 26-pin
17-01818-01	1	Control panel assembly to bulkhead
17-01844-01	1	Temperature sensor cable, to H405
17-01897-02	2	7" DWMBB/A to DWMBB/B cables, from XMI slot E
17-02240-03	1	Scalar/vector intermodule VIB cable
17-02475-01	1	H7206-B J6 to H7206-B bezel
17-02485-01	1	H7206-B to H7236-A battery backup unit (300V, external) (optional)
17-02494-01	1	H7206-B J12 to H7206-B bezel
17-02500-01	1	Power supply enable cable
17-02521-01	1	H405 to XMI fail safe enable
17-02522-01	1	H7242 inhibit (VAX 6000 Models 300 and 400)
17-02632-01	1	TK signal cable
17-02759-01	1	H405 to H7206-B fail safe enable cable
17-02833-01	1	TK to system control assembly 26- to 50-pin ribbon
17-02975-01	1	H7206-B to H7236-A BBU

## Appendix B

# XMI Backplane Connectors

---

Figure B-1 shows the numbering scheme used on the XMI backplane connectors. Note that the view is from the rear of the backplane.

**Figure B-1: XMI Backplane Connector Numbering**

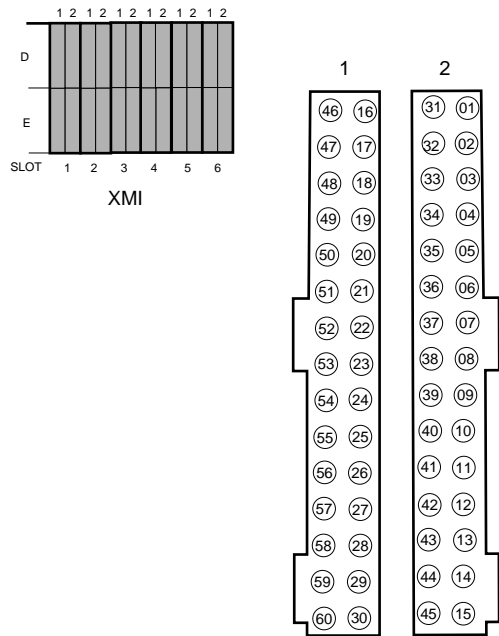

Numbering for each D & E section in XMI backplane

msb-0712-90



## Appendix C

# Module Handling

---

This appendix gives detailed instructions on handling scalar and vector processor modules for VAX 6000 systems. The sections include:

- Handling Modules
- Inserting Modules

# C.1 Handling Modules

**Handle the processor modules with care. The technology used on the VAX 6000 series modules is more vulnerable to static than past technology. Also, these modules have 25 mil leads to the chips; these leads are very small, close together, and easily bent.**

Figure C-1: Holding VAX 6000 Series Processor Modules

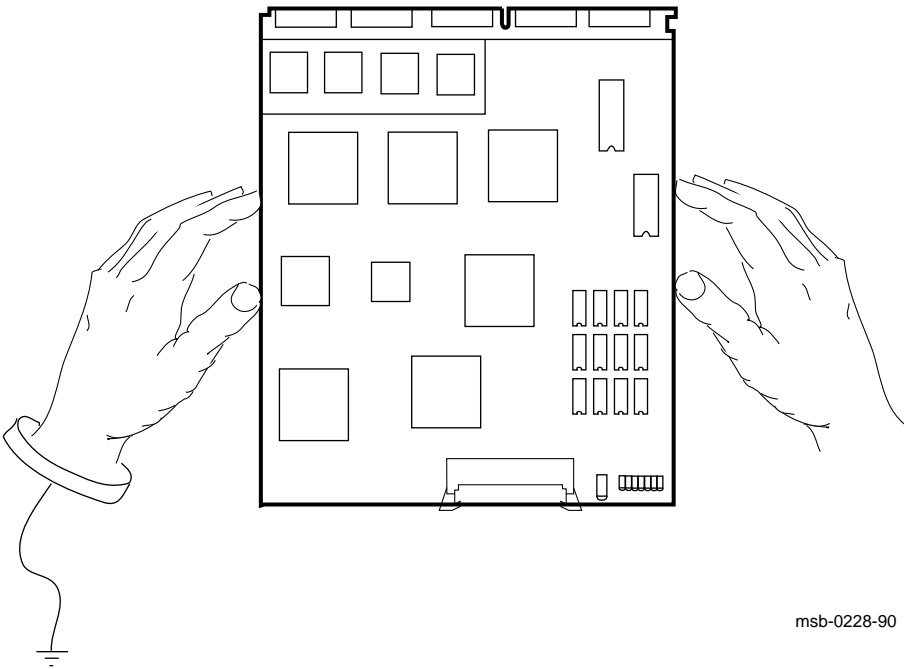

msb-0228-90

The VAX 6000 series modules require careful handling. Prepare yourself and the work area before handling these modules. Roll up your sleeves and remove any jewelry. Figure C-1 shows the proper way to hold the module.

Follow these handling procedures to avoid damaging the processor modules:

1. Always wear an antistatic wrist strap.
2. Before removing the module from its ESD box, place the box on a clean, stable surface.

Be sure the box will not slide or fall. **Never** place the box on the floor. And be sure no tools, papers, manuals, or anything else that might damage the module is near it. Some components on this module can be damaged by a 600-volt static charge; paper, for example, can carry a charge of 1000 volts.

3. Hold the module only by the edges, as shown in Figure C-1.

Do not hold the module so that your fingers touch any 25 mil devices, leads, or XMI fingers. Be sure you do not bend the module as you are holding it.

4. Be sure nothing touches the module surface or any of its components.

If anything touches the module, components or leads can be damaged. This includes the antistatic wrist strap, clothing, jewelry, cables, components on other modules, and anything in the work area (such as tools, manuals, or loose papers).

## C.2 Inserting Modules

Figure C-2: Inserting the Scalar Processor in an XMI Card Cage

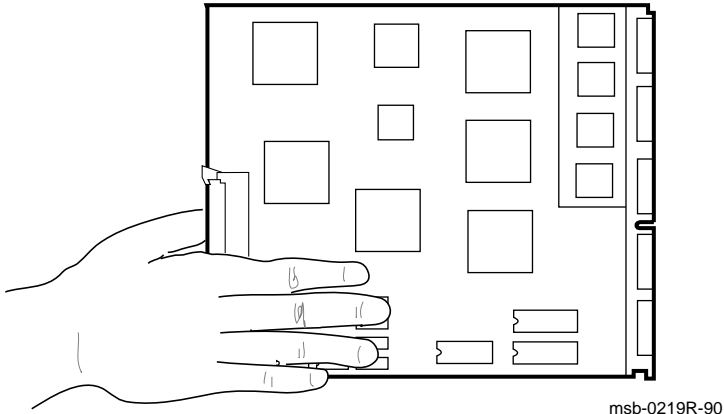
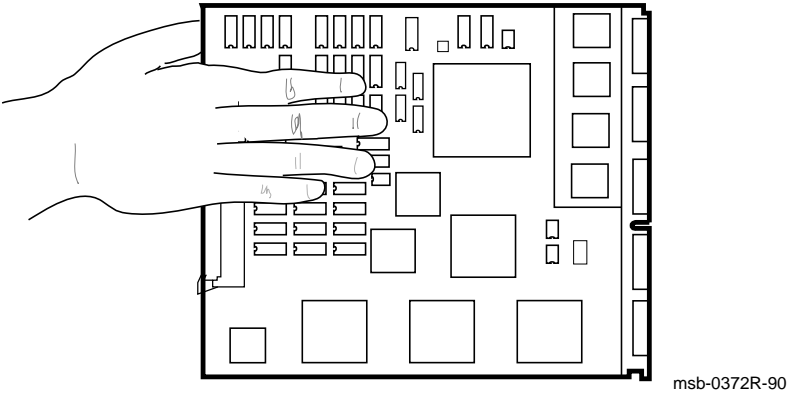

Figure C-3: Inserting the Vector Processor in an XMI Card Cage



You must take special precautions when moving the processor modules in or out of the XMI card cage.

1. Be sure, when inserting a module in or removing it from the XMI card cage, that no part of the module comes in contact with another module or a cable.
2. When you swap out a module, place it in an ESD box or on an ESD mat before you install the new module.

If you place the module on an ESD mat, make sure the mat is on a stable, uncluttered surface, with side 1 of the module facing up (the side with the heat sinks). Do not put it on the top of the system cabinet. And never slide the module across any surface. The leads on the components are fragile and can be damaged by contact with fingers or any surface.

3. Hold the XMI card cage handle while removing or inserting the module. If it is not held in place, the handle can spring down and damage the module.
4. When inserting a module in the card cage, grasp it as shown in Figure C-2 or in Figure C-3, being careful not to touch any 25 mil devices, and slide it slowly and gently into the slot.
5. **Do not attach the repair tag to the module.**

Place the repair tag in the plastic bag attached to the bottom of the ESD box. Allowing the repair tag to come in contact with the module can cause damage to a component.

## Appendix D

# VAX 6000 Platforms

---

Use Table D–1 to determine which platform you are servicing.

- If you are servicing the XMI-2 platform, use this manual for removal and replacement instructions.
- If you are servicing the XMI-1 platform, see *VAX 6000–400 Options and Maintenance* or *VAX 6200/6300 VAXserver 6200/6300 Options and Maintenance*.

**Table D–1: VAX 6000 Platform Differences**

Item	XMI-1 Platform	XMI-2 Platform
Processor	Model 200, 300, or 400	Model 300, 400, or 500
XMI Backplane	XMI-1	XMI-2
Cabinet Number	70-24900-XX	H9657-CA/CB/CU
XMI I/O Adapters	None <sup>1</sup>	CIXCD, DEMNA, KDM70
XTC	20-29176-01	20-29176-02
Power Regulators	H7214 (+5V, +5VBB, +13.5V) H7215 (+12V, -12V, -5V, -2V)	H7214 (+5V, +13.5V) H7215 (+12V, -12V, -5V, -2V) H7242 (+3.3V, +13.5V)
Power and Logic Unit	H7206-A	H7206-B
Battery Backup Unit	H7231-N	H7236-A
VAXBI	Required DWMBA adapter 2 6-slot channels	Optional DWMBB adapter 1 12-slot channel
Console Load Device	TK50 or TK70	TK70 or NI CDROM

<sup>1</sup>Any XMI I/O adapter may be installed in the XMI-1 backplane.

## A

---

- AC power controller
  - See H405 AC power controller
- Air filters, 6-2 to 6-5
  - removal and replacement, 6-3
  - specifications, 6-3
- Airflow sensor, 6-6 to 6-7
  - location, 6-6
  - operation, 6-7
  - removal, 6-7
  - replacement, 6-7
  - specifications, 6-6
- Altitude, 1-5

## B

---

- Backplane connectors, B-1
- Battery aging information, 5-43
- Battery backup unit
  - See H7236-A battery backup unit
  - location, 1-8
- Battery reset, 5-43
- Blower assembly, 6-10 to 6-15
  - front, 6-12
  - operation, 6-11
  - rear, 6-13
  - removal, 6-15
  - replacement, 6-15
  - specifications, 6-10 to 6-11

## C

---

- Cabinet
  - doors, 6-2 to 6-5
    - specifications, 6-3
  - front door removal, 6-3
  - front door replacement, 6-3

## Cabinet (Cont.)

- rear door removal, 6-5
- rear door replacement, 6-5
- side panel, 6-16 to 6-17
  - removal, 6-17
  - specifications, 6-17
- Cable list, A-1 to A-2
- Configuration rules
  - VAXBI, 3-20 to 3-21
  - XMI, Model 500, 2-20 to 2-21
  - XMI, Models 300 and 400, 2-18 to 2-19
- Connector cleaning supplies, 2-23, 3-23
- Control panel assembly, 4-12 to 4-15
  - location, 4-12
  - removal, 4-14 to 4-15
  - replacement, 4-14 to 4-15
  - specifications, 4-12 to 4-13
- Control panel location, 1-6
- Cooling system
  - characteristics, 1-5
  - location, 1-6, 1-8

## D

---

- Daughter card, 2-3, 2-4
- DWMBB adapter, 2-3, 3-2

## E

---

- Electrical specifications, 1-5

## F

---

- Field-replaceable units, 1-10 to 1-11
- Filter board, 4-16 to 4-19

Filter board (Cont.)  
location, 4-16  
removal, 4-18 to 4-19  
replacement, 4-18 to 4-19

## H

---

H405 AC power controller, 5-28 to 5-31  
location, 5-28  
operation, 5-29  
removal, 5-31  
replacement, 5-31  
specifications, 5-29  
H7206-B power and logic unit, 5-20 to 5-25  
fan, 5-26 to 5-27  
removal, 5-27  
replacement, 5-27  
location, 5-20  
removal, 5-25  
replacement, 5-25  
specifications, 5-21  
switches and indicators, 5-22  
H7214 power regulator, 5-8 to 5-11  
location, 5-8  
operation, 5-9  
removal, 5-11  
replacement, 5-11  
specifications, 5-9  
H7215 power regulator, 5-12 to 5-15  
location, 5-12  
operation, 5-13  
overtemperature switch, 6-7  
removal, 5-15  
replacement, 5-15  
specifications, 5-13  
H7236-A battery backup unit, 5-36 to 5-45  
battery aging information, 5-43  
battery pack removal, 5-40 to 5-41  
battery pack replacement, 5-42 to 5-43

H7236-A battery backup unit (Cont.)  
battery reset, 5-43  
enclosure removal, 5-45  
enclosure replacement, 5-45  
fan removal, 5-39  
fan replacement, 5-39  
location, 1-6, 5-36  
new battery reset button, 5-43  
operation, 5-37  
specifications, 5-37  
H7242 power regulator, 5-16 to 5-19  
location, 5-16  
operation, 5-17  
removal, 5-19  
replacement, 5-19  
specifications, 5-17  
Humidity, 1-5

## I

---

I/O bulkhead space  
location, 1-8  
Interlock Inhibit signals, 6-7, 6-11

## M

---

Module handling, C-1 to C-5

## N

---

New battery reset button, 5-43

## P

---

Platform differences, D-1  
Power and logic unit  
See H7206-B power and logic unit  
Power controller  
See H405 AC power controller  
Power failure, 5-37  
Power regulators  
See also H7214, H7215, or H7242 power regulator  
location, 1-6, 1-8  
Power subsystem, 5-1 to 5-45



Power subsystem (Cont.)

- design, 5-2 to 5-3
- modules, 5-6 to 5-7
- specifications, 5-4 to 5-5

Processor modules

- handling, C-2 to C-5
- inserting into card cage, C-5

---

**R**

- <REFERENCE>(XMI) card cage  
location, 1-6, 1-8

---

**S**

Side panel, 6-16 to 6-17

- removal, 6-17
- specifications, 6-17

System

- dimensions, 1-5
- environmental characteristics, 1-5
- front view, 1-6 to 1-7
- physical characteristics, 1-5
- physical description, 1-2 to 1-5
- rear view, 1-8 to 1-9

System control assembly, 4-1 to 4-23

- removal, 4-4 to 4-7
- replacement, 4-4 to 4-7
- specifications, 4-2 to 4-3

---

**T**

Tape drive, 4-20 to 4-23

- location, 1-6, 4-20
- removal, 4-22 to 4-23
- replacement, 4-22 to 4-23
- specifications, 4-20 to 4-21

Temperature

- maximum, 1-5
- operating, 1-5

Temperature sensor, 6-8 to 6-9

- location, 6-8
- operation, 6-9
- removal, 6-9

Temperature sensor (Cont.)

- replacement, 6-9
- specifications, 6-9

Torque values, VAXBI, 3-7

TOY clock battery, 4-16 to 4-19

- location, 4-16
- removal, 4-18 to 4-19
- replacement, 4-18 to 4-19

Transformer, 5-32 to 5-35

- location, 5-32
- removal, 5-35
- replacement, 5-35
- specifications, 5-33

---

**V**

VAXBI card cage, 3-1 to 3-23

- description, 3-2 to 3-7
- location, 1-6, 1-8
- removal, 3-8 to 3-15
- replacement, 3-16 to 3-19
- specifications, 3-4 to 3-7
- subassemblies, 3-6
- system use, 3-2 to 3-3

VAXBI configuration rules, 3-20 to 3-21

VAXBI troubleshooting, 3-22 to 3-23

---

**X**

XMI-1 platform, D-1

XMI-2 platform, D-1

XMI backplane connectors, B-1

XMI card cage, 2-1 to 2-23

- description, 2-2 to 2-5
- removal, 2-6 to 2-13
- replacement, 2-14 to 2-17
- specifications, 2-4 to 2-5
- system use, 2-2 to 2-3

XMI configuration rules

- Model 500, 2-20 to 2-21
- Models 300 and 400, 2-18 to 2-19

XMI troubleshooting, 2-22 to 2-23

XTC power sequencer, 4-8 to 4-11

XTC power sequencer (Cont.)

location, 1-8

removal, 4-10 to 4-11

replacement, 4-10 to 4-11

specifications, 4-8 to 4-9