

VAXft Systems

Configuration Guide

EK-VXFTB-PG-002

September 1991

This document describes how to configure VAXft Systems hardware.

Revision/Update Information: This manual supersedes the *VAXft 3000 Guide to Fault Tolerant Systems*, EK-VXFTA-PG-001.

Operating System and Version: VMS Version 5.4 and higher for Model 310; VMS Version 5.4-3 for Models 110, 410, 610, and 612

Software Version: VAXft System Services Version 1.2

VMS Volume Shadowing: Phase II

Hardware Version: VAXft Systems

Digital Equipment Corporation
Maynard, Massachusetts

First Printing, May 1990
Revised, September 1991

The information in this document is subject to change without notice and should not be construed as a commitment by Digital Equipment Corporation.

Digital Equipment Corporation assumes no responsibility for any errors that may appear in this document.

Any software described in this document is furnished under a license and may be used or copied only in accordance with the terms of such license. No responsibility is assumed for the use or reliability of software or equipment that is not supplied by Digital Equipment Corporation or its affiliated companies.

Restricted Rights: Use, duplication, or disclosure by the U.S. Government is subject to restrictions as set forth in subparagraph (c)(1)(ii) of the Rights in Technical Data and Computer Software clause at DFARS 252.227-7013.

© Digital Equipment Corporation 1991.

All Rights Reserved.

Printed in U.S.A.

The Reader's Comments form at the end of the hardcopy version of this document requests the user's critical evaluation in preparing future documentation.

The following are trademarks of Digital Equipment Corporation: DEC, DELNI, DECserver, DECsystem, DSSI, MicroVAX, Packnet, ThinWire, TK, VAX, VAX DOCUMENT, VAX-11/780, VAXcluster, VAXft, VAXsimPLUS, VAX Volume Shadowing, VMS, VT420, and the DIGITAL logo.

The following is a third-party trademark: IBM is a registered trademark of International Business Machines Corporation.

This document is available in printed and online versions.

This document was prepared with VAX DOCUMENT, Version 1.2.

Navigational Map for the VAXft Systems Documentation

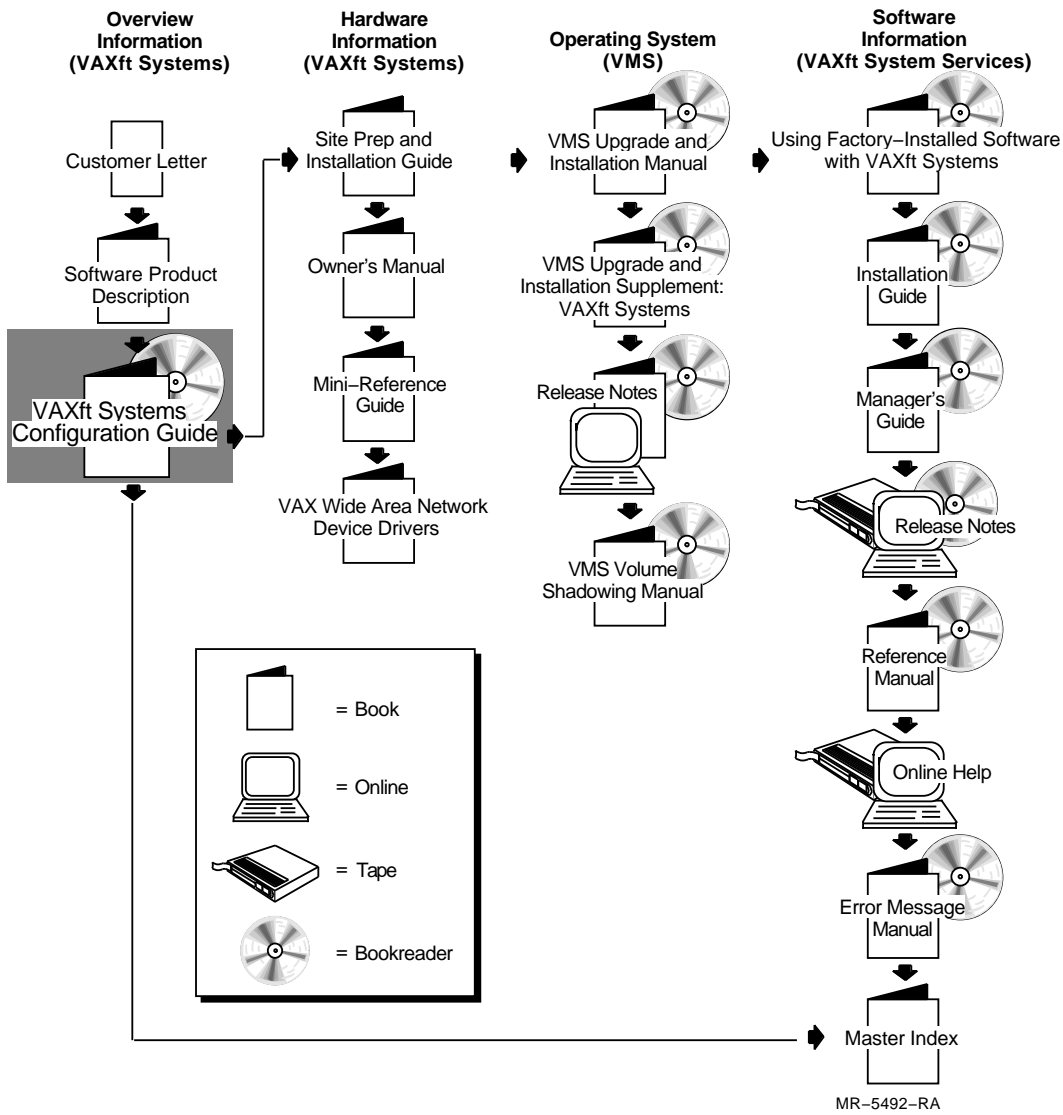

Contents

Preface	ix
1 Introduction	
1.1 System Architecture	1-2
1.2 System Hardware	1-4
1.2.1 CPU Modules	1-6
1.2.2 Memory	1-6
1.2.3 Crosslink	1-6
1.2.4 System I/O Controller	1-6
1.2.4.1 Ethernet	1-7
1.2.4.2 DSSI	1-7
1.2.4.3 System Console	1-7
1.2.5 Synchronous Communications with the DEC WANcontroller 620	1-8
1.3 System Software	1-8
1.3.1 VMS Operating System	1-9
1.3.2 VMS Volume Shadowing	1-9
1.3.3 VAXft System Services	1-10
1.4 Power Subsystem	1-11
1.5 Environmental Monitor	1-12
2 VAXft Systems Configurations and Options	
2.1 Mass Storage Options	2-2
2.2 The VAXft Model 110 System	2-4
2.3 VAXft Model 310/410 Base System	2-5
2.4 VAXft Model 310/410 System with Storage Expansion	2-7
2.5 VAXft Model 610 Base System	2-10
2.6 VAXft Model 610 Systems with Storage Expansion	2-12
2.7 VAXft Model 612 VAXcluster Base System	2-17
2.8 VAXft Model 612 VAXcluster System with Storage Expansion ...	2-17

3 Communications

3.1	Ethernet Connections	3-1
3.1.1	DECserver Terminal Servers	3-3
3.1.2	Ethernet Communications Servers	3-4
3.2	DEC WANcontroller 620	3-4

4 System Service and Warranty

4.1	Service and Repair Features	4-1
4.2	System Warranty	4-2
4.2.1	Standard Warranty	4-2
4.2.2	List Warranty	4-2
4.3	Digital Assisted Services Program	4-2

Glossary

Index

Figures

1-1	VAXft System Diagram	1-3
1-2	Seven-Slot Backplane	1-5
1-3	Five-Slot Backplane	1-5
1-4	Most Common Causes of System Failure Due to Environmental Conditions	1-12
2-1	Fixed Disks and Replacements	2-3
2-2	VAXft Model 110 System	2-5
2-3	VAXft Model 310/410 Base System	2-6
2-4	VAXft Model 310/410 System with Storage Expansion	2-8
2-5	VAXft Model 610 Base System	2-11
2-6	VAXft Model 610 System with One Storage Expansion Cabinet	2-13
2-7	VAXft Model 610 System with Two Storage Expansion Cabinets	2-14
2-8	VAXft Model 612 VAXcluster Base System	2-18
2-9	VAXft Model 612 VAXcluster with Storage Expansion	2-20
3-1	System Connected to a Single Ethernet	3-2
3-2	System Connected to Dual Ethernet	3-3

3-3	Synchronous Communication Lines Using Y-Connectors	3-5
-----	--	-----

Tables

2-1	Common Options for the VAXft Systems	2-1
2-2	Options for the Model 110 System	2-4
2-3	Options for the Model 310/410 Base System	2-6
2-4	Options for the Model 310/410 System with Storage Expansion	2-7
2-5	Options for the Model 610 Base System	2-10
2-6	Options for Model 610 System with One Storage Expansion Cabinet	2-12
2-7	Options for Model 610 System with Two Storage Expansion Cabinets	2-16
2-8	Options for the Model 612 VAXcluster Base System	2-17
2-9	Options for the Model 612 VAXcluster System with Storage Expansion	2-22

Preface

This manual is a guide to configuring the members of the VAXft Systems family of fault-tolerant systems.

Intended Audience

This guide is intended for Digital customers or potential customers who are interested in VAXft fault-tolerant systems configurations.

Related Documentation

The Navigational Map on page iii shows all the documents that contain information on the VAXft Systems.

Conventions

This document uses italics to indicate a new term described either in the text or in the glossary. Italics also identify the title of a document.

Introduction

Digital Equipment Corporation offers a family of VAXft systems to satisfy your fault-tolerant computing requirements. The systems vary in processing power and amount of mass storage. Supported systems are:

- VAXft Model 110 System
- VAXft Model 310 or 410 Base System
- VAXft Model 310 or 410 System with Storage Expansion
- VAXft Model 610 Base System
- VAXft Model 610 Systems with Storage Expansion
- VAXft Model 612 Dual-Node VAXcluster Base System
- VAXft Model 612 Dual-Node VAXcluster System with Storage Expansion

In designing VAXft fault-tolerant systems, Digital developed an architecture that features the following innovations for fault-tolerant computing:

- **Fully redundant hardware**
One of each type of element in the system is always available.
- **No single point of hardware failure**
No failure of a single hardware element is capable of bringing down the entire system.
- **No single point of repair**
All repairs can be made without disrupting running applications.
- **Uninterruptible Power Supply (UPS)**
Power outages of short duration, brownouts, and power fluctuations, which are the most common environmental causes of computer failures, do not affect VAXft systems.

- **Self-checking checkers**

These checkers ensure that system integrity is not compromised if a fault occurs in the checking logic.

By combining these innovations with the highly successful VAX architecture, Digital has extended the range of its VAX family of computers into state-of-the-art fault-tolerant systems. Digital also supports its fault-tolerant systems with an industry-leading service offering.

Digital's strategy is to provide you with a fault-tolerant VAX computer system that you can run without change in your application code and that is fully compatible with existing VAX systems.

VAXft systems use the VMS operating system, VMS Volume Shadowing, and a layered product, VAXft System Services, to support its hardware architecture. VAXft systems will run any application or layered product designed to run on the VMS operating system. In this way, Digital continues to protect your investment in applications development.

Because VAXft systems are based on the popular VAX architecture, you can mix conventional and fault-tolerant systems in your networked configurations. Therefore, you only have to put a fault-tolerant system where it is needed and can use conventional or high availability systems elsewhere. All VAX systems present a common programming and operator interface.

Use a VAXft system in any of the following ways:

- Standalone system
- Front end system in a distributed application
- Back end system in a distributed application

Digital's VAX architecture is the most expandable in the industry. Digital offers you conventional, high-availability, and fault-tolerant systems, all within the same architecture. The VAXft family provides a seamless upgrade for your critical applications in a networked environment that results in a high degree of system reliability and availability.

1.1 System Architecture

Each VAXft system consists of two identical sets of components configured in dual *zones*. Each zone is a complete computer system, fully capable of servicing the application by itself. Figure 1-1 illustrates the basic system design and shows some of the redundant features of VAXft systems.

Figure 1-1 VAXft System Diagram

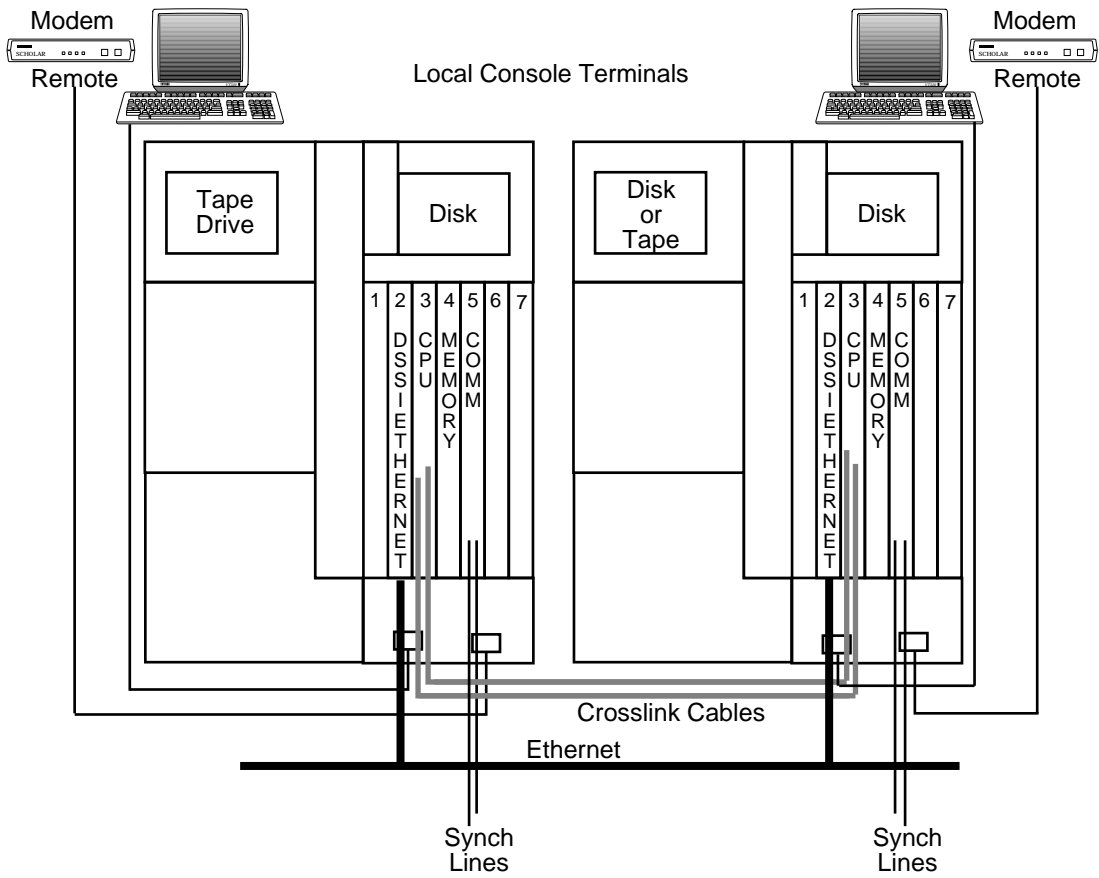

MR-5523-AD

This dual zone design ensures that there is no single point of hardware failure, and that a single fault or hardware failure in one zone does not cause system failure. Separate power supplies for each zone (including separate power cords) minimize system failure from loss of external power in a single zone.

Each zone in a VAXft system contains identical CPU and memory modules. Both CPUs and memory in each zone execute the same instruction at the same time. This type of operation is called *lockstep*. Because the zones are peers and operate in this synchronous fashion, no delay is caused by a transfer of operations from a failed CPU to the remaining CPU. Indeed, there is no

transfer at all. With each zone running in lockstep, the remaining zone simply continues to operate while the failed zone is halted waiting for repair.

To maximize the benefits of redundancy for fault tolerance, VAXft system interconnects are also duplicated to eliminate any connectivity losses due to cable failure. *Crosslink* cables connect both system zones and provide parallel data paths between the zones.

1.2 System Hardware

There are seven module slots in each zone (five in the Model 110) for the CPU, system I/O controller modules, memory modules, and communications controller modules. They reside in the module slots and connect directly to the backplane in each zone. Each zone has its own backplane to eliminate the possibility of a single point of failure at this level. The modules are specifically designed for simple maintenance and can be inserted or removed from the front of the system cabinet. Figures 1-2 and 1-3 show the arrangement of the system modules.

The minimum configuration of required logic modules in each zone of the VAXft systems includes one CPU, one memory module, and one system I/O controller, and those required modules must be placed as shown in Figures 1-2 and 1-3. If an additional system I/O controller is needed, the first slot is used on the seven-slot backplane and the fourth or fifth on the five-slot backplane. Synchronous communication modules are not required, but are available if applications require such modules. In Chapter 2, the maximum number of memory, system I/O controller, and synchronous communication modules is given for each system. If you select the maximum for one of these types of modules, be aware that you will be limiting the number of other modules, sometimes to the minimum number. For example, if you configure the maximum number of synchronous communication controllers (four modules for models with seven slots and two for the Model 110 with five slots), you will be limited to one memory module and one system I/O controller.

Figure 1-2 Seven-Slot Backplane

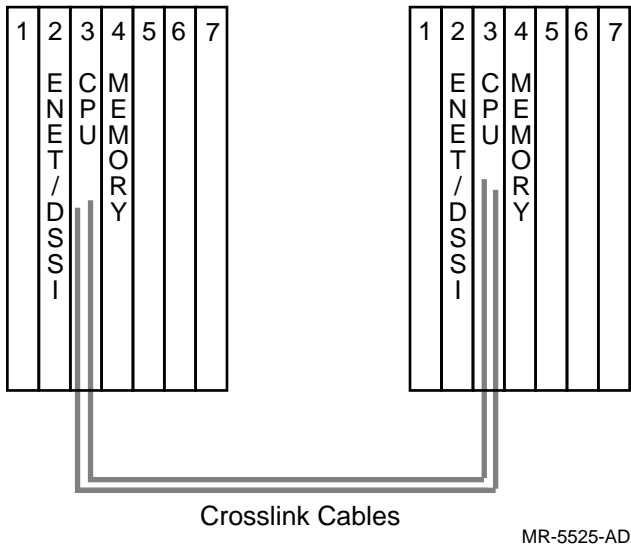
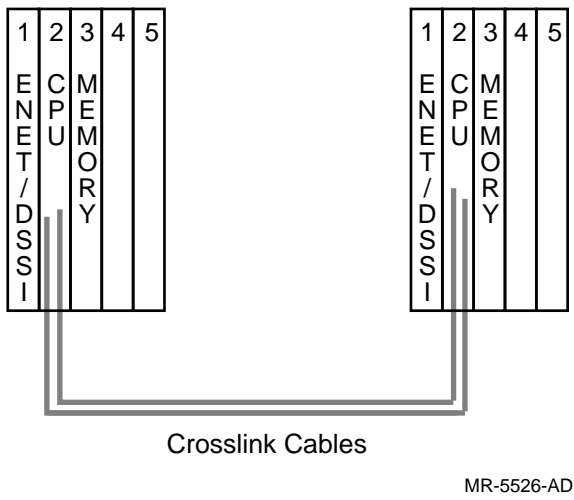

Figure 1-3 Five-Slot Backplane



1.2.1 CPU Modules

A VAXft system has two CPU modules, one in each zone, which run in lockstep. If one CPU module fails during operation, the other CPU module continues to provide service to the application.

Each system provides the following VUPs of processing power:

- Model 110 System — 2.4 VUPs
- Model 310 System — 3.8 VUPs
- Models 410 and 610 System — 6.0 VUPs
- Model 612 VAXcluster System — 12.0 VUPs

One VUP is equal to the processing power of the VAX-11/780 system. Each CPU module also includes a system logic clock for synchronization of the zones, a 1-kilobyte internal cache memory, and an external cache memory, 32 kilobytes for the Model 310 and 128 kilobytes for the Models 410, 610, and 612. The Model 110 has no external cache memory.

1.2.2 Memory

Each memory module for a VAXft system contains 32 megabytes of fully checked memory on a single board. Each memory module features single-bit correction, double-bit detection, address and function verification, and parity checking. Up to four (three for the Model 110) memory modules can be configured in each zone. The minimum system configuration has one memory module in each zone. For lockstep operation, each system zone must be configured with equal amounts of memory.

1.2.3 Crosslink

Crosslink cables provide the communications paths between the CPU modules in each zone. Between the zones, the crosslink provides two types of paths, serial and parallel. The serial path is used to establish initial communications between the zones; the parallel path operates only after the clocks in each zone have been synchronized.

1.2.4 System I/O Controller

System I/O controller modules contain Ethernet and DSSI ports for asynchronous communications and mass storage. These modules also contain the interface to the console ports.

1.2.4.1 Ethernet

Ethernet connections are provided to connect a VAXft system to a Local Area Network (LAN) or an Ethernet-based VAXcluster system. For redundant Ethernet support, a single connection in each zone is made to a single Ethernet. For redundant connections to dual or multiple Ethernets, up to four system I/O controller modules can be configured in each zone.

Support for asynchronous communications devices, such as user terminals, is provided through the use of Ethernet terminal servers. An Ethernet port can be connected to a thick wire or ThinWire Ethernet. See the *Networks and Communications Buyer's Guide*, for more information.

Expanded synchronous communications are supported through Ethernet-based communications line servers and gateways. Q-bus devices can be connected through DEC Commserver products such as the DEC Commserver 100/150.

1.2.4.2 DSSI

The DSSI provides a data path between the VAXft system and the mass storage devices. By having a DSSI in a system I/O controller module configured in each zone, the VAXft system provides redundant access to the mass storage devices in each zone. When the need for disk storage requires system expansion, the DSSI provides the connections from the CPU to the disks in expansion cabinets and allows the disks to be accessed by both zones.

The DSSI is also the interconnect for the dual-node VAXft Model 612 VAXcluster system. By providing connections between both nodes as well as to the mass storage between the zones in both nodes, the DSSI gives the Model 612 VAXcluster system the ability to provide the twice the processing power and load sharing of two Model 610 systems.

1.2.4.3 System Console

The system I/O controller also contains the interface to the system console. To support console operations, the system I/O controller modules are configured redundantly, one in each zone, to enable four console ports. The ports support, in each zone, one local console terminal and provide access to one remote console terminal by modem, as shown in Figure 1-1. A minimum of two console terminals is required with the system. The international model of the VT240 with attached LA75 printer is recommended as the console terminal.

All four physical console lines operate as a single logical system console. Output appears on all four console terminals, and input can be entered from any console terminal.

The VAXft system console is a combination of hardware and software that enables the system to boot itself and lets you perform routine system maintenance.

The console functions enable you to:

- Issue console commands
- Boot the system either automatically or interactively
- Install the VMS operating system
- Examine control and status registers and run diagnostic tests
- View messages from the console program, diagnostics, and the VMS system
- Provide remote dial-in/dial-out capability
- Provide input to the operating system for the system manager or operator

During normal operation, only one console terminal is required for system operations. Two console terminals are normally active during system repair. One can be used to manage the system, while the other is used to manage system repair. Remote console ports can be used for system access from remote locations.

1.2.5 Synchronous Communications with the DEC WANcontroller 620

Synchronous communications for VAXft systems is provided by the DEC Wide Area Network Controller 620 (DEC WANcontroller 620), which is a two-line synchronous fault-tolerant communications controller option designed specifically for VAXft systems.

The DEC WANcontroller 620 supports Digital-standard layered communications software for the DECnet-VAX, VAX Packetnet System Interface (PSI), VAX 2780/3780 BISYNC Protocol Emulator, and DECnet/SNA products.

The two lines are independently managed and operated so different protocols can run simultaneously. The DEC WANcontroller 620 is capable of line speeds up to 64 kilobits per second.

The maximum DEC WANcontroller 620 modules that can be configured is eight, four per zone, providing 16 synchronous nonredundant communication lines. Configuring the modules redundantly enables a maximum of eight lines.

1.3 System Software

Many VAXft fault-tolerant features are managed by software. Therefore, the VMS operating system software and layered products are integral components of the fault-tolerant operation of VAXft systems.

All VAXft systems come with the following software:

- VMS operating system software

- VAXft System Services software, which supports the system's fault-tolerant hardware features
- VMS Volume Shadowing, which allows for redundancy of disk storage
- DECnet-VAX software for the Ethernet connections

All systems include licenses for the required software. A DECnet-VAX end-node license is provided with the base system, but if multiple Ethernet support is necessary, the DECnet-VAX full-function upgrade is required. On all VAXft systems except the Model 110 system, the VMS operating system with VMS Volume Shadowing and the VAXft System Services Software is factory installed on one of the required disks.

1.3.1 VMS Operating System

Support for VAXft systems fault tolerant operation is built into the VMS operating system (Version 5.4 and later). Thus, the multitude of VMS layered products and VMS applications can be run on VAXft systems without modification or recompiling. In addition, in situations where operators are already trained in VMS operations, little additional training is needed for VAXft systems.

1.3.2 VMS Volume Shadowing

VMS Volume Shadowing is a significant component of the VAXft fault-tolerant capability. It enables all disks, including the system disk, to be shadowed within a single system or across multiple systems on the Ethernet. VMS Volume Shadowing replicates data at the volume level and ensures that the loss of a disk drive does not affect the ability of an application to run. Shadowing means that two or three disks are grouped into a shadow set so the same data is written to all disks in the set. Refer to the *VMS Volume Shadowing Manual* for more information.

If one zone is down due to planned maintenance or repair, the mass storage devices contained in that zone are unavailable to the operational zone. Shadow set members in that zone must be updated when the zone is returned to operation.

Volume shadowing is not required for all disks on VAXft systems. However, volume shadowing enables the system to provide access to important data whenever it is needed, so disks containing critical data should be shadowed.

There is no restriction on the number of allowable shadow sets. The maximum number of members for a shadow set is three. Members of a shadow set should reside on different DSSI buses and in separate cabinets to optimize data accessibility and availability within the VAXft system.

To determine which disks require shadowing, answer the following questions:

- **Is availability of data on the disk critical?**

If so, this disk should be shadowed. For example, the system disk is critical and needs to be shadowed, but data needed for an annual report may not require shadowing if there is a consistent procedure for backing up report data.

- **Is the data written to the disk critical?**

Sometimes shadowing of a disk is necessary because the data is so critical that it cannot be lost. For example, a disk that records transactions at an automatic teller machine should be shadowed because the data must be available immediately to adjust balances, and a copy must be retained for reference at all times. In this case, a simple backup procedure would be insufficient because data could be lost if the drive where it is recorded fails. Shadowing of this disk would ensure that the data is available at all times for immediate access or reference at a later date.

- **Must a disk be shadowed to adhere to legal or auditing requirements?**

Some businesses must adhere to corporate and government requirements to protect data. Shadowing can be used to fulfill these requirements.

1.3.3 VAXft System Services

VAXft System Services runs in conjunction with the VMS operating system to support the fault-tolerant features of VAXft systems.

Features of VAXft System Services software include support for the following capabilities:

- Automatic failover of hardware
- Hardware fault isolation and recovery
- Automatic dial-out notification of faults
- Configuration management of I/O components

VAXft System Services software also provides DCL-level commands to start, stop, and show zones.

VAXft System Services also provide tools and utilities you use to manage the system.

The FTSS\$CONTROL Utility allows you to define the dial-out telephone numbers used by the autonotification feature. See Section 4.1, Service and Repair Features, for more details on autonotification.

The Failover Set Manager Utility enables you to manage members of the failover sets of Ethernet adapters. The Failover Set Manager allows the addition or removal of failover set members and displays member status. See the *VAXft System Services Reference Manual* and *VAXft System Services Manager's Guide* for more details.

1.4 Power Subsystem

VAXft systems feature a universal AC power system that supports 120 VAC requirements for the U.S. and 240 VAC requirements for the international market. The power system provides the voltages required to operate all internal components of the system, including the computer logic, memory, disks, tape, and cooling fans. The system features separate power cables for each cabinet, to enable connection to external power sources.

External power can be 120 VAC or 240 VAC on all models; 48 to 60 VDC is available on the Model 410. See the *VAXft Systems Site Preparation and Installation Guide*, for more details.

Loss of external power is the leading cause for environmentally induced system failure. See Figure 1-4 for an illustration of typical outage causes leading to system failure. VAXft systems can counteract this loss of external power by switching to the UPS. The UPS allows for a controlled shutdown of the system to eliminate loss of data. The integral UPS in each zone permits the system to tolerate brownouts, or brief or full outages due to loss of external power source, by supplying power to all internal components for up to 30 minutes in each 24-hour period. The VAXft Model 110 system does not support an integral UPS; an external UPS must be ordered if you require uninterruptible power.

If external power returns within 30 minutes, the system automatically switches back to the external power source.

For critical applications that tolerate no downtime, an external generator should be included in the installation for times when power may be lost for longer than 30 minutes.

External devices such as console terminals, user terminals, modems, terminal servers, as well as internal tape loaders are not powered by VAXft systems in the event of a power outage. An external UPS used to support these devices is available from Digital.

Figure 1-4 Most Common Causes of System Failure Due to Environmental Conditions

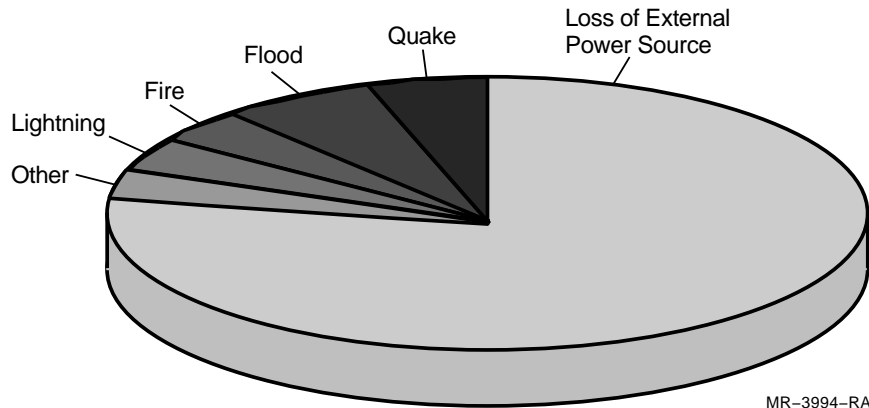

1.5 Environmental Monitor

VAXft Model 110, 310, and 410 systems are designed to operate in a normal temperature-controlled office space, while VAXft Model 610 and 612 systems are designed to operate in a computer room environment. Temperature thresholds are 10°C and 40°C, or about 50°F and 104°F. If the environment exceeds the system's thresholds, a shutdown occurs automatically.

The system has an internal environmental monitor, called Power and Cooling Monitor (PCM), in each zone to ensure that thresholds on the high end are not exceeded. Fan speed is increased when room temperature rises above an acceptable threshold. The PCM reports harmful temperature fluctuations to the system, and the autonotification dialout procedure is initiated to notify the System Manager or Digital Services.

VAXft Systems Configurations and Options

As described in Chapter 1, there is a variety of VAXft systems. The configuration for each of these VAXft systems is described in detail in this chapter.

The options for memory, mass storage, and buses are common to all the systems. Table 2-1 gives each of the options and their capacities. The model numbers for these options differ slightly depending on the VAXft model; refer to the latest version of the *VAX Systems DECsystems Systems and Options Catalog* for complete order numbers.

Table 2-1 Common Options for the VAXft Systems

Option	Description
TF70C	290-megabyte cartridge tape drive; optional on all models.
TF85C	2.6-gigabyte cartridge tape drive; optional on Models 610/612.
TF857	18.2-gigabyte tape loader for unattended backup; optional on Models 610/612.
RF31/RF72 disks	All systems come with a minimum of two disks (except Model 110). Disks can be fixed or removable. RF31 disks have a capacity of 381 megabytes, while RF72 disks have a capacity of 1 gigabyte.
MS520	ECC mirrored memory; all systems come with one memory module.
KFE52	System I/O controller module for connection to DSSI, Ethernet and console; all systems come with at least one system I/O controller module.
DSF32	DEC WANcontroller 620 two-line synchronous communication controller; optional on all models.

2.1 Mass Storage Options

Although a tape drive or tape loader is not required for any VAXft system, Digital recommends that you purchase one for backup. If you have a need for large amounts of unattended tape backup on a Model 610 or 612, the TF857 tape loader is the recommended tape option. It has a capacity of up to 18.2 gigabytes of storage in up to seven tape cartridges. Normally, TK85K 2.1-gigabyte tapes are used, but TF70C, TK50, and other cartridge tapes can be read. If you need rapid backup of data, consider the TF85C cartridge tape drive, which can complete full backup in under an hour. It provides a sustained transfer rate of up to 800 kilobytes per second and has a capacity of up to 2.6 gigabytes.

If you choose not to have a tape drive/loader, you must use the Ethernet for software upgrades.

In VAXft systems with storage expansion, all disks must be located in the expansion cabinets and are accessed through the DSSI bus. Most of them are fixed disks. If you want to add one removable disk, you cannot use fixed disk 5. In the Model 310/410, you can have a tape instead of the removable disk, but the tape drive still replaces fixed disk 5. On the Model 610, each optional tape drive replaces fixed disk 4, even though the tape drive is in the system cabinet and disk 4 is in the expansion cabinet. On the Model 612, the tape drives in Node 1 do not replace any of the fixed disk because the tape drives have a separate DSSI bus. Figure 2-1 shows one section of an expansion cabinet on a Model 610 with the disks that can be replaced by removable disks and/or tape drives.

Figure 2-1 Fixed Disks and Replacements

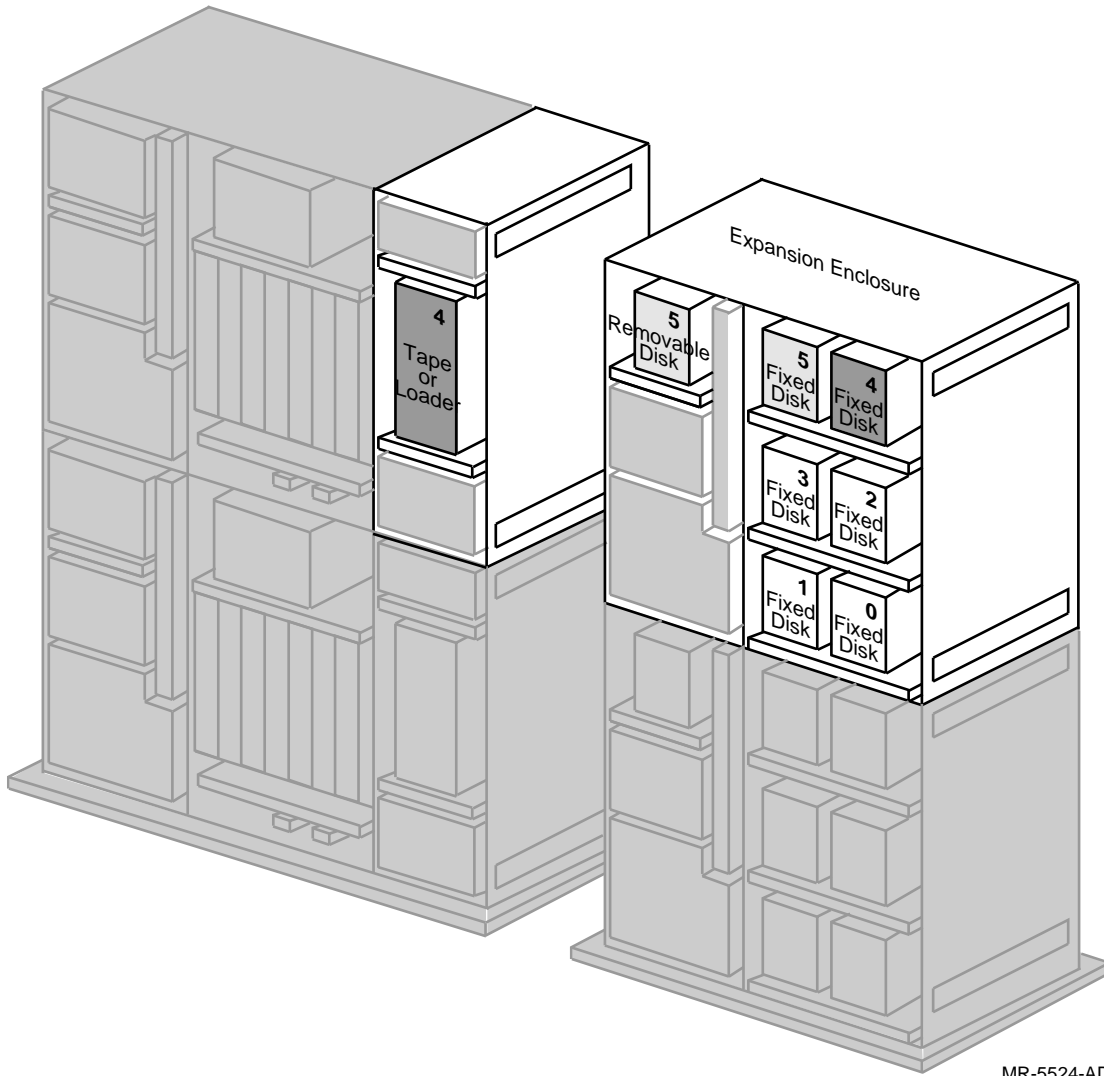

MR-5524-AD

2.2 The VAXft Model 110 System

The VAXft Model 110 system is the minimum VAX fault-tolerant system configuration available from Digital Equipment Corporation. This system features low cost with limited mass storage. Both zones of the Model 110 system are contained in a single cabinet. Table 2-2 gives the system components for the Model 110 system; and Figure 2-2 shows the configuration of the VAXft Model 110 system.

Table 2-2 Options for the Model 110 System

Option	Description
TF70C Tape Drive	Optional; a maximum of one tape drive can be configured for Zone B.
RF31/RF72 Fixed Disks	The minimum system comes without disks, but disks are a required option. RF31s and RF72s cannot be mixed. Configure mass storage in the one of the following combinations: <ul style="list-style-type: none">• Three RF31 disks in each zone for a total of six RF31 disks• Three RF31 disks in Zone A and two RF31 disks plus one tape in Zone B for a total of five RF31 disks and one tape• Two RF72 disks in each zone for a total of four RF72 disks• Two RF72 disks in Zone A and one RF72 disk plus one tape in Zone B for a total of three RF72 disks and one tape
MS520 Memory Module	A maximum of three memory modules can be configured per zone.
KFE52 System I/O Controller Module	Up to two additional system I/O controller modules can be configured in each zone to provide additional connections to Ethernet lines. (An additional DSSI is not available.)
DSF32 DEC WANcontroller 620	A maximum of four WAN modules (two per zone) can be configured to give eight synchronous, nonredundant lines.

Figure 2-2 VAXft Model 110 System

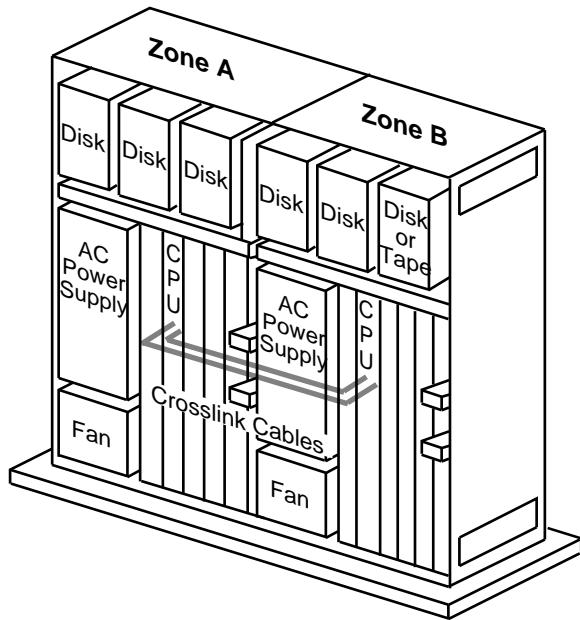

MR-5494-AD

2.3 VAXft Model 310/410 Base System

The VAXft Model 310 and the VAXft Model 410 base systems are identical in everything but the CPU. The Model 310 CPU has 3.8 VUPs of processing power, while the Model 410 has 6.0 VUPs. To upgrade from a VAXft Model 310 system to a VAXft Model 410 system requires the replacement of the Model 310 CPU with the Model 410 CPU. Unlike the Model 110, the Model 310/410 is expandable (see Section 2.4). The Model 310/410 base system is recommended if your requirements for online nonshadowed disk storage do not exceed four gigabytes. Table 2-3 gives the system components available for the Model 310/410 base system; and Figure 2-3 shows the configuration of the VAXft Model 310/410 base system.

Table 2-3 Options for the Model 310/410 Base System

Option	Description
TF70C Tape Drive	Optional; a maximum of two tape drives can be configured.
RF31/RF72 Disks	a maximum of four removable disks can be configured.
MS520 Memory Module	A maximum of four memory modules can be configured per zone.
KFE52 System I/O Controller Module	Up to three additional system I/O controller modules can be configured in each zone to provide additional connections to Ethernet lines.
DSF32 DEC WANcontroller 620	A maximum of eight WAN modules (four per zone) can be configured per system.

Figure 2-3 VAXft Model 310/410 Base System

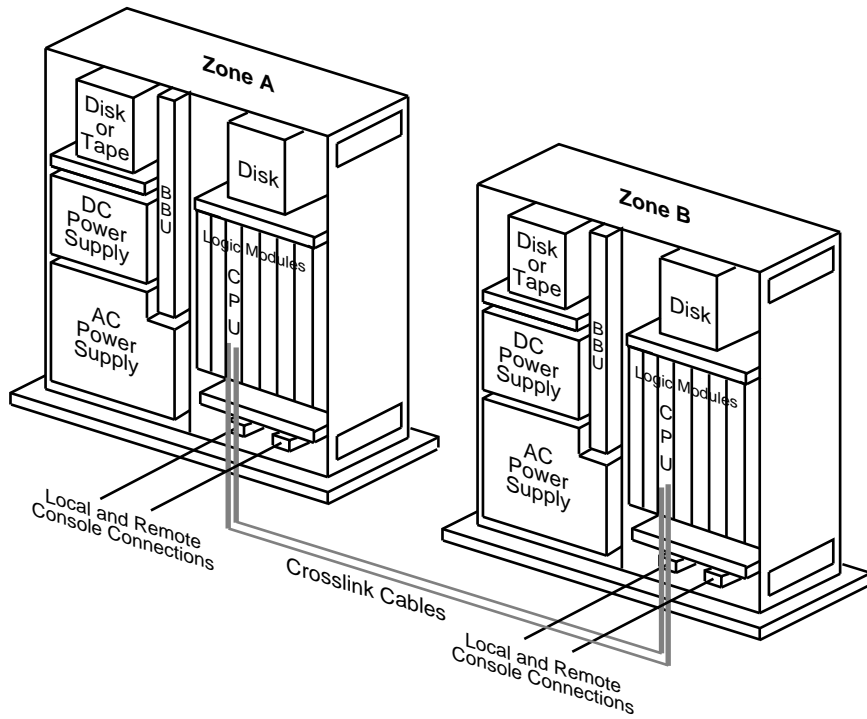

MR-5493-AD

2.4 VAXft Model 310/410 System with Storage Expansion

The VAXft Model 310 or VAXft Model 410 system with storage expansion provides up to 12 gigabytes of nonshadowed mass storage. Figure 2-4 shows the configuration of the Model 310/410 system with storage expansion.

The Model 310/410 system with storage expansion consists of two system cabinets and two expansion cabinets. The system cabinets are similar to the Model 310/410 base system, but contain no mass storage. The expansion cabinets are connected to the system cabinets by dual DSSI buses to enable access to mass storage by both zones.

Table 2-4 gives the system components for the Model 310/410 system with storage expansion.

Table 2-4 Options for the Model 310/410 System with Storage Expansion

Option	Description
TF70C Tape Drive	Optional; a maximum of two tape drives can be configured.
RF31/RF72 Disks	A maximum of 12 fixed disks can be configured; a maximum of two removable disks can replace two fixed disks.
MS520 Memory Module	A maximum of four memory modules can be configured per zone.
KFE52 System I/O Controller Module	The system comes with two system I/O controller modules per zone for DSSI lines and redundant Ethernet connections. Up to two additional modules can be configured in each zone to provide additional Ethernet connections.
DSF32 DEC WANcontroller 620	A maximum of six WAN modules (three per zone) can be configured for a maximum of 12 synchronous nonredundant lines.

Figure 2-4 VAXft Model 310/410 System with Storage Expansion

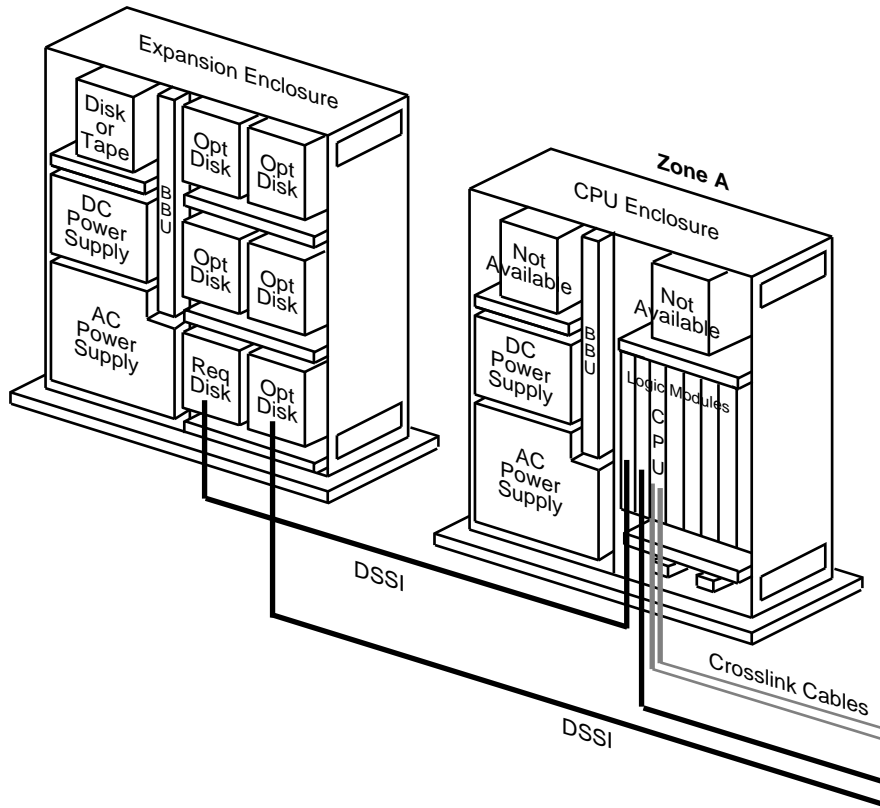

MR-5548-AD

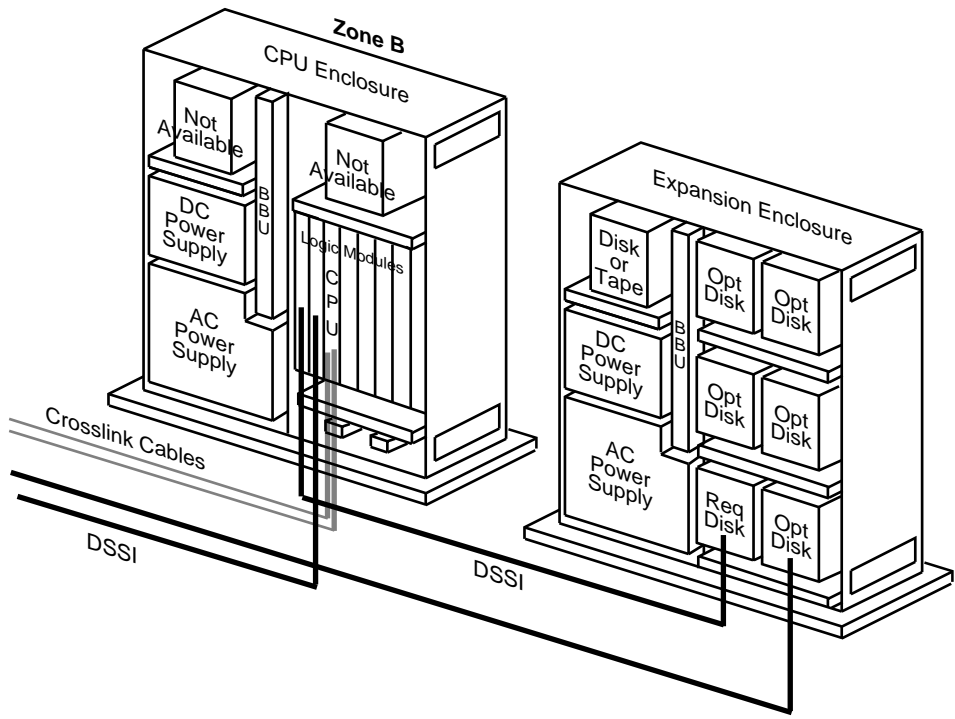

MR-5549-AD

2.5 VAXft Model 610 Base System

The VAXft Model 610 base system is available in a 60-inch cabinet with one zone on top of the other, rather than side-by-side. The Model 610 base system is recommended if your requirements for online nonshadowed storage do not exceed 4 gigabytes. The Model 610 is expandable (see Section 2.6). Table 2-5 gives the system components for the Model 610 base system; and Figure 2-5 shows the configuration of the VAXft Model 610 base system.

Table 2-5 Options for the Model 610 Base System

Option	Description
TF70C/TF85C Tape Drive	Optional; a maximum of two tape drives can be configured.
TF857 Tape Loader	Optional; can replace one or both tape drives.
RF31/RF72 Disks	A maximum of four removable disks can be configured.
MS520 Memory Module	A maximum of four memory modules can be configured per zone.
KFE52 System I/O Controller Module	Up to three additional system I/O controller modules can be configured in each zone to provide additional connections to Ethernet lines.
DSF32 DEC WANcontroller 620	A maximum of eight WAN modules (four per zone) can be configured for a total of 16 synchronous, nonredundant lines.

Figure 2-5 VAXft Model 610 Base System

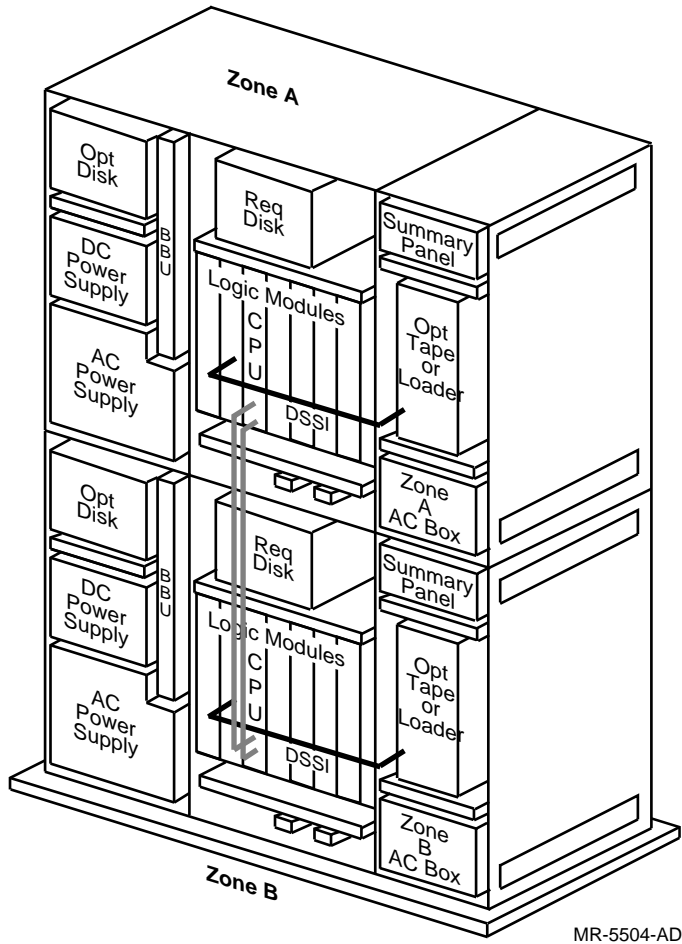

2.6 VAXft Model 610 Systems with Storage Expansion

Two Model 610 systems with storage expansion are available to provide up to 24 gigabytes of nonshadowed mass storage. Figures 2-6 and 2-7 show the configurations of the VAXft Model 610 systems with storage expansion.

The system cabinet is similar to the Model 610 base system, but it contains no disks. It can contain one or two tape drives. The system with the single expansion cabinet requires two system I/O controller modules (in slots 1 and 2), while the system with the two expansion cabinets requires four system I/O controller modules (in slots 1, 2, 6, and 7). Figures 2-6 and 2-7 show the slots that the DSSI buses use.

Table 2-6 gives the system components available for the Model 610 system with one storage expansion cabinet.

Table 2-6 Options for Model 610 System with One Storage Expansion Cabinet

Option	Description
TF70C/TF85C Tape Drive	Optional; a maximum of two tape drives can be configured.
TF857 Tape Loader	Optional; can replace one or both tape drives.
RF31/RF72 Disks	A maximum of 12 fixed disks can be configured; two removable disks can replace two fixed disks.
MS520 Memory Module	A maximum of four memory modules can be configured per zone.
KFE52 System I/O Controller Module	The system comes with two system I/O controller modules per zone for DSSI lines and redundant Ethernet connections. Up to two additional modules can be configured in each zone to provide additional Ethernet connections.
DSF32 DEC WANcontroller 620	A maximum of six WAN modules (three per zone) can be configured to give 12 synchronous nonredundant lines.

Figure 2-6 VAXft Model 610 System with One Storage Expansion Cabinet

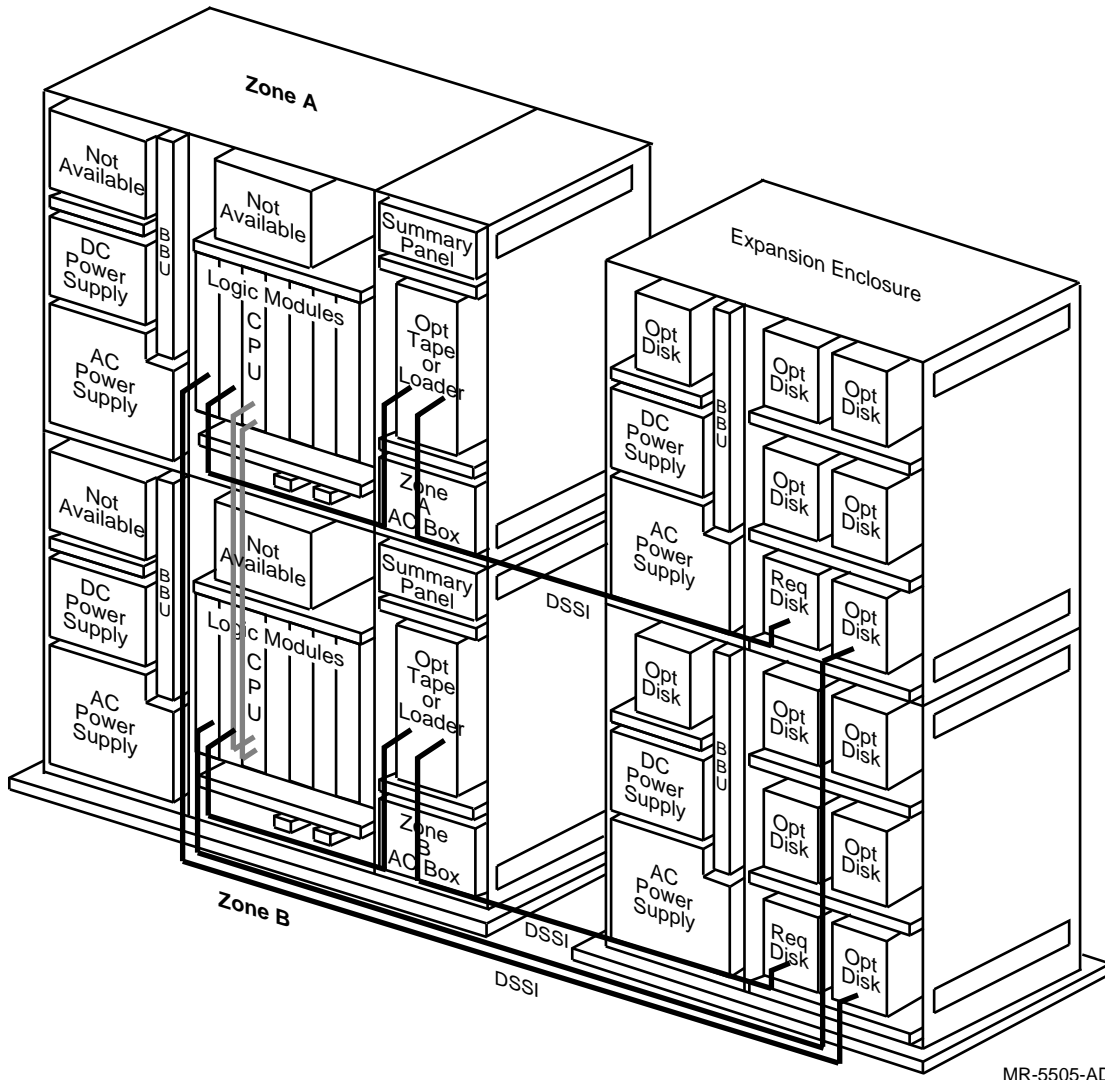
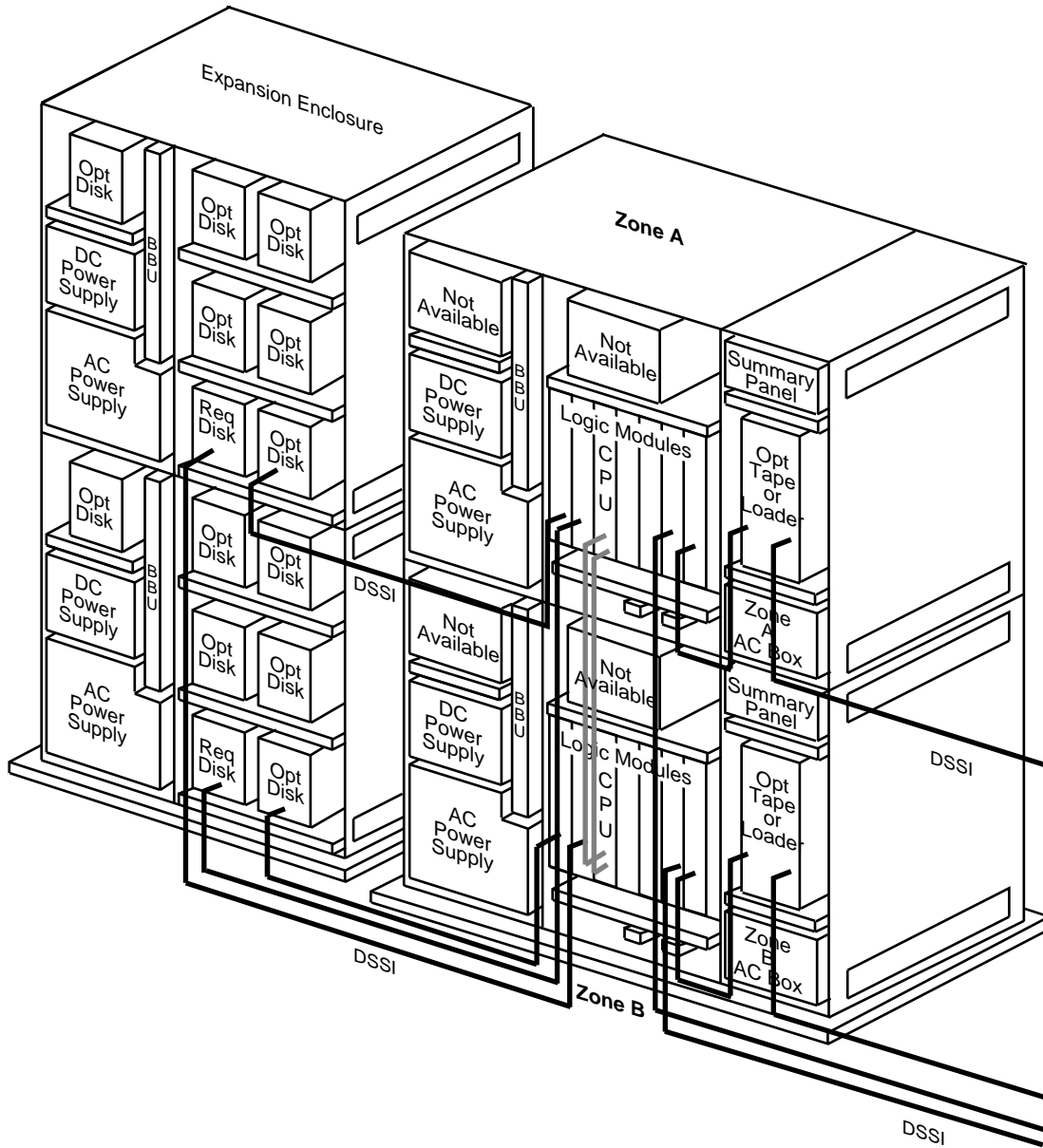
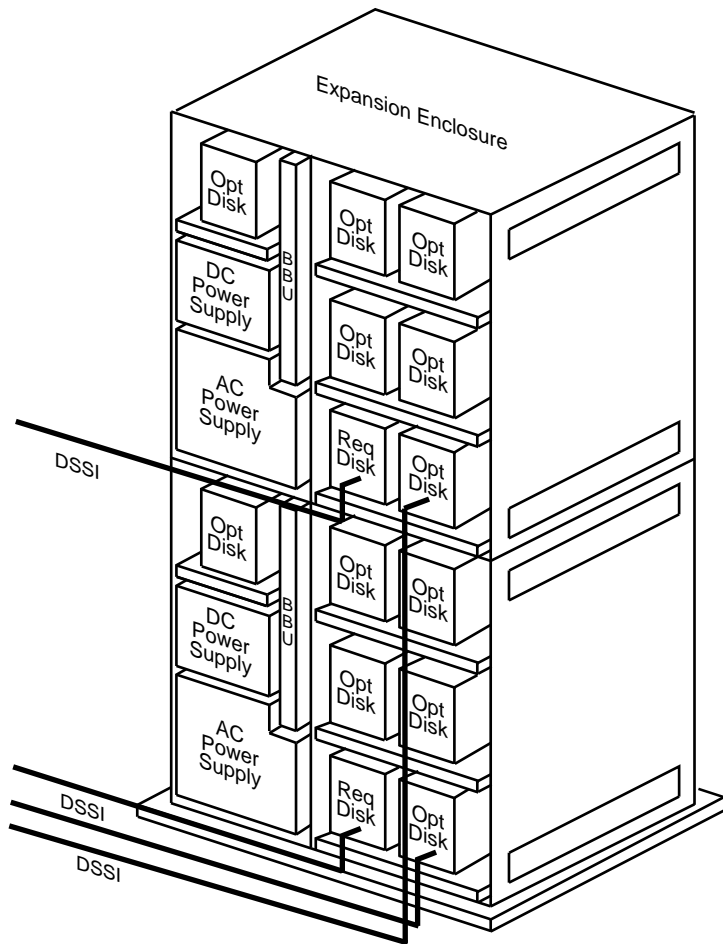

Figure 2-7 VAXft Model 610 System with Two Storage Expansion Cabinets



MR-5542-AD



MR-5543-AD

Table 2-7 gives the system components available for the Model 610 system with two storage expansion cabinets.

Table 2-7 Options for Model 610 System with Two Storage Expansion Cabinets

Option	Description
TF70C/TF85C Tape Drive	Optional; a maximum of two tape drives can be configured.
TF857 Tape Loader	Optional; can replace one or both tape drives.
RF31/RF72 Disks	A minimum of four fixed disks is required. A maximum of 24 fixed disk can be configured. Four removable disks can replace four fixed disks.
MS520 Memory Module	A maximum of two memory modules can be configured per zone.
KFE52 System I/O Controller Module	The system comes with four system I/O controller modules per zone for DSSI lines and Ethernet connections, which is the maximum number of modules that can be configured.
DSF32 DEC WANcontroller 620	A maximum of two WAN modules (one per zone) can be configured to give four synchronous nonredundant lines.

2.7 VAXft Model 612 VAXcluster Base System

The VAXft Model 612 VAXcluster base system is a dual-node VAXcluster system consisting of two VAXft Model 610 systems sharing a single expansion cabinet that contains the DSSI disk devices. The Model 612 VAXcluster system has 12 VUPs of processing power, twice that of a Model 610 system. The Model 612 is expandable (see Section 2.8). Table 2–8 gives the system components for the Model 612 VAXcluster base system; and Figure 2–8 shows the configuration of the VAXft Model 612 VAXcluster base system.

Table 2–8 Options for the Model 612 VAXcluster Base System

Option	Description
TF70C/TF85C Tape Drive	Optional; maximum of two tape drives can be configured in Node 1.
TF857 Tape Loader	Optional; can replace one or both tape drives.
RF31/RF72 Disks	A maximum of 12 fixed disks can be configured. A maximum of two removable disks can replace two fixed disks.
MS520 Memory Module	A maximum of four memory modules per zone per node can be configured.
KFE52 System I/O Controller Module	Node 1 has an additional I/O controller per zone for a tape drive and redundant Ethernet connections. Up to two additional modules can be configured in each zone in Node 1 and three modules in each zone in Node 2 to provide additional connections to Ethernet lines.
DSF32 DEC WANcontroller 620	A maximum of six WAN modules (three per zone) for Node 1 and a maximum of eight (four per zone) for Node 2 can be configured for a total of 14 synchronous, nonredundant lines per VAXcluster system.

2.8 VAXft Model 612 VAXcluster System with Storage Expansion

The VAXft Model 612 VAXcluster system with storage expansion offers the maximum fault-tolerant system configuration currently available. It provides up to 24 gigabytes of nonshadowed mass storage.

The Model 612 VAXcluster system with storage expansion consists of two Model 610 systems sharing the disks in two expansion cabinets, as shown in Figure 2–9.

Figure 2-8 VAXft Model 612 VAXcluster Base System

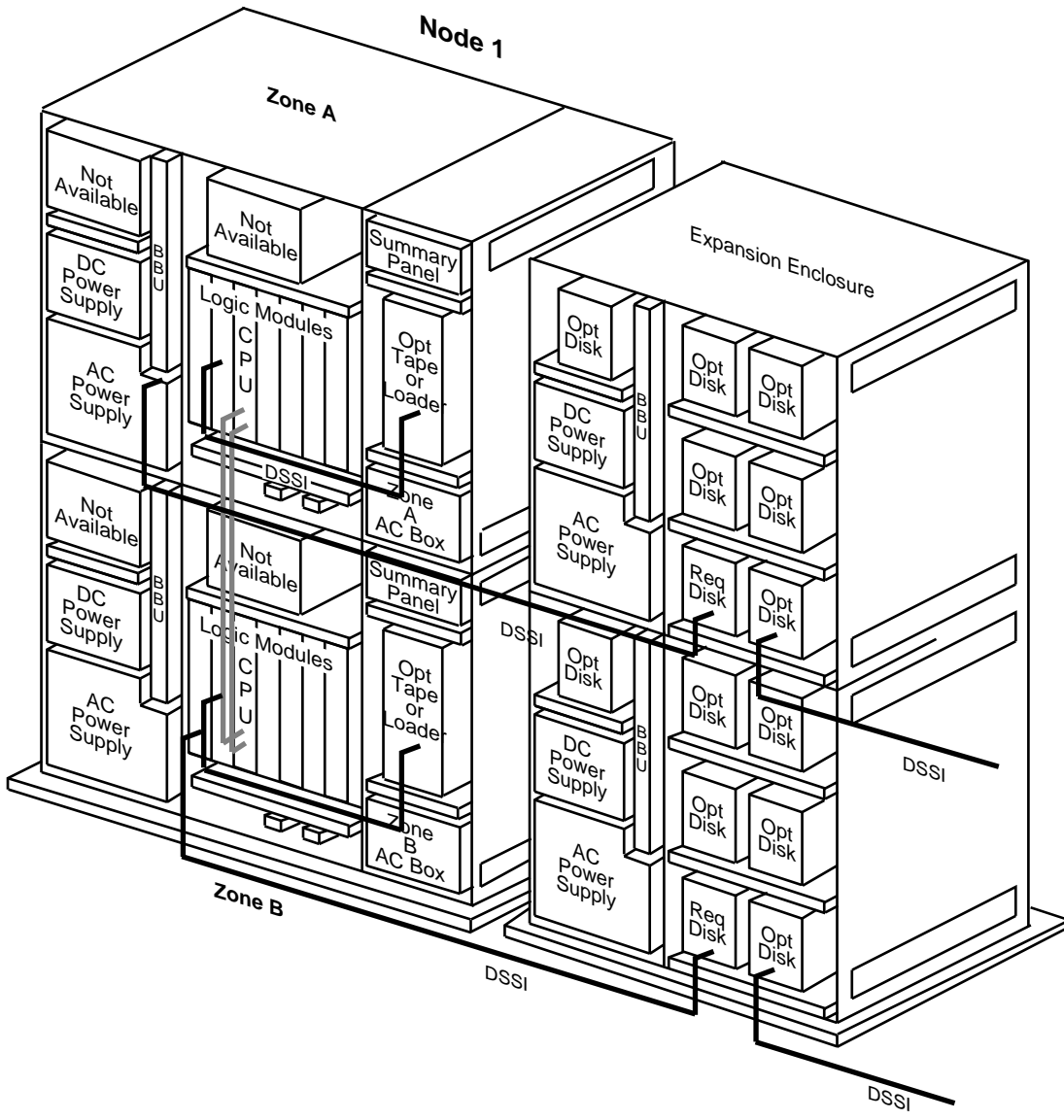

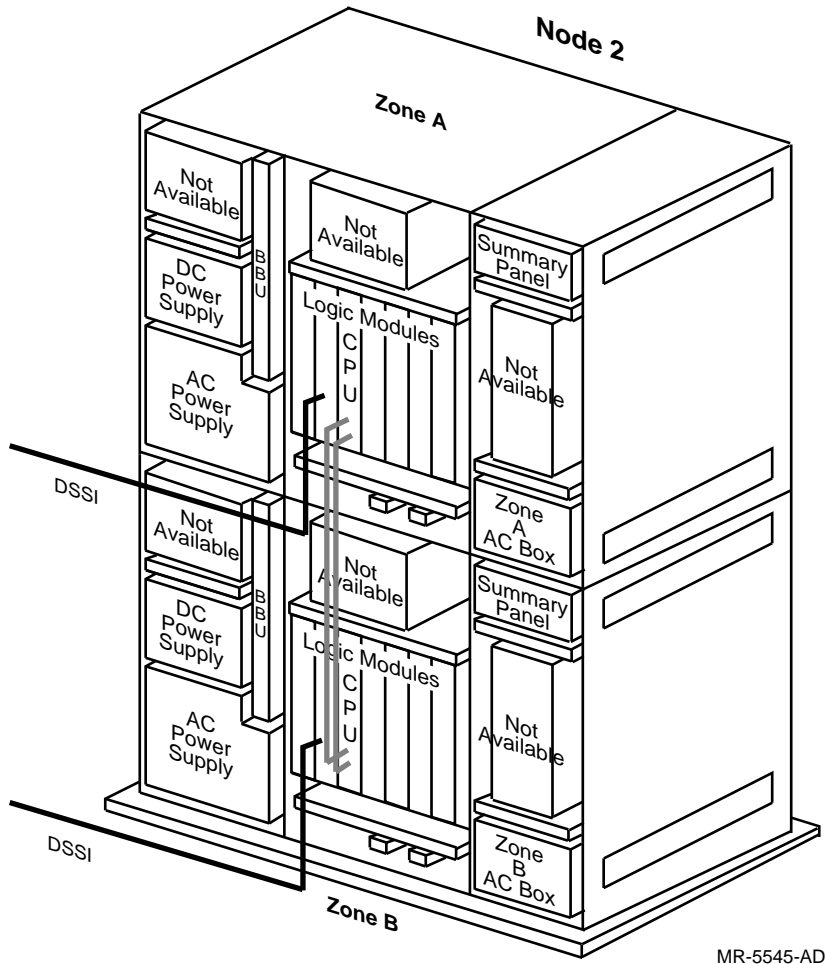
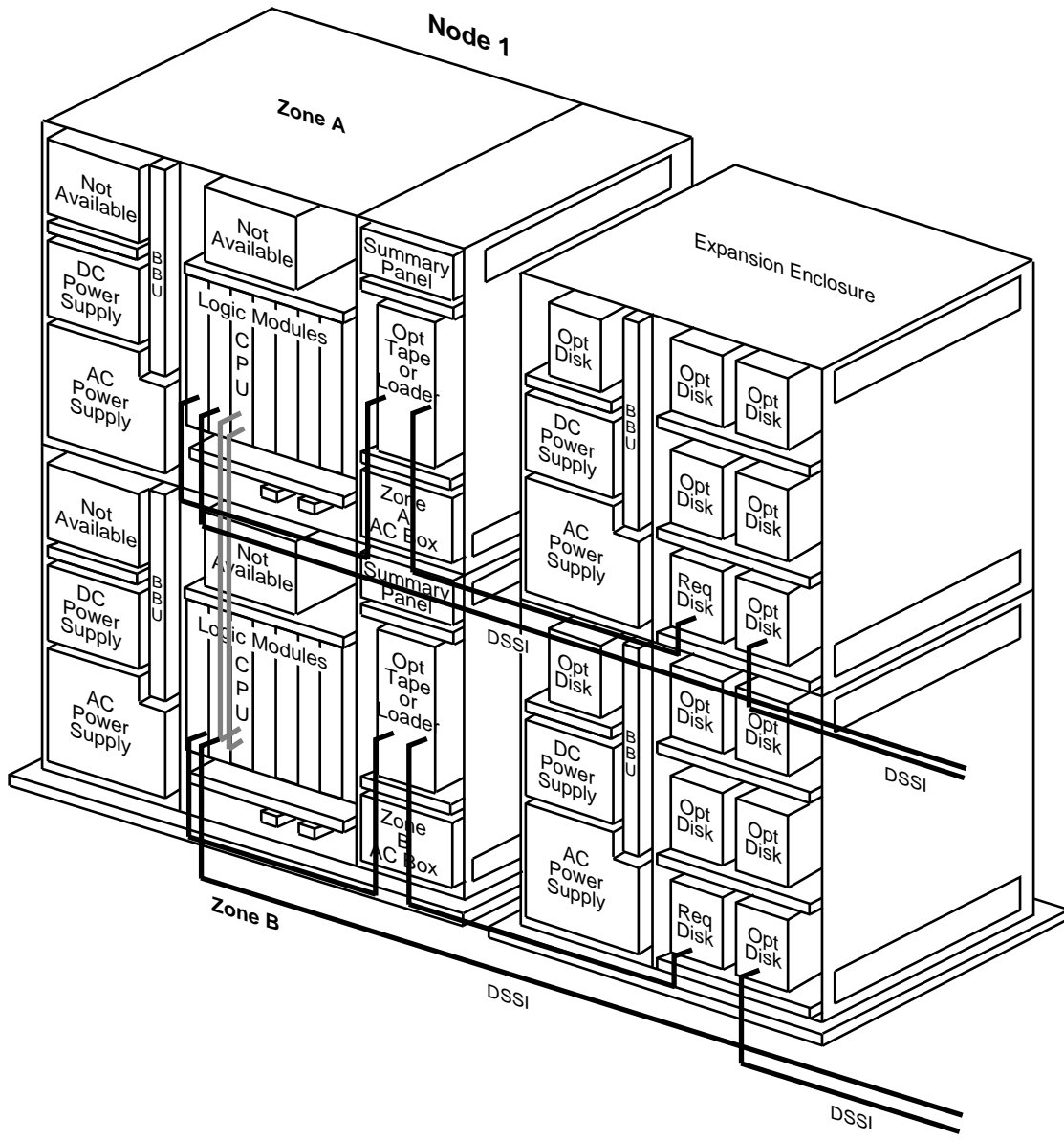
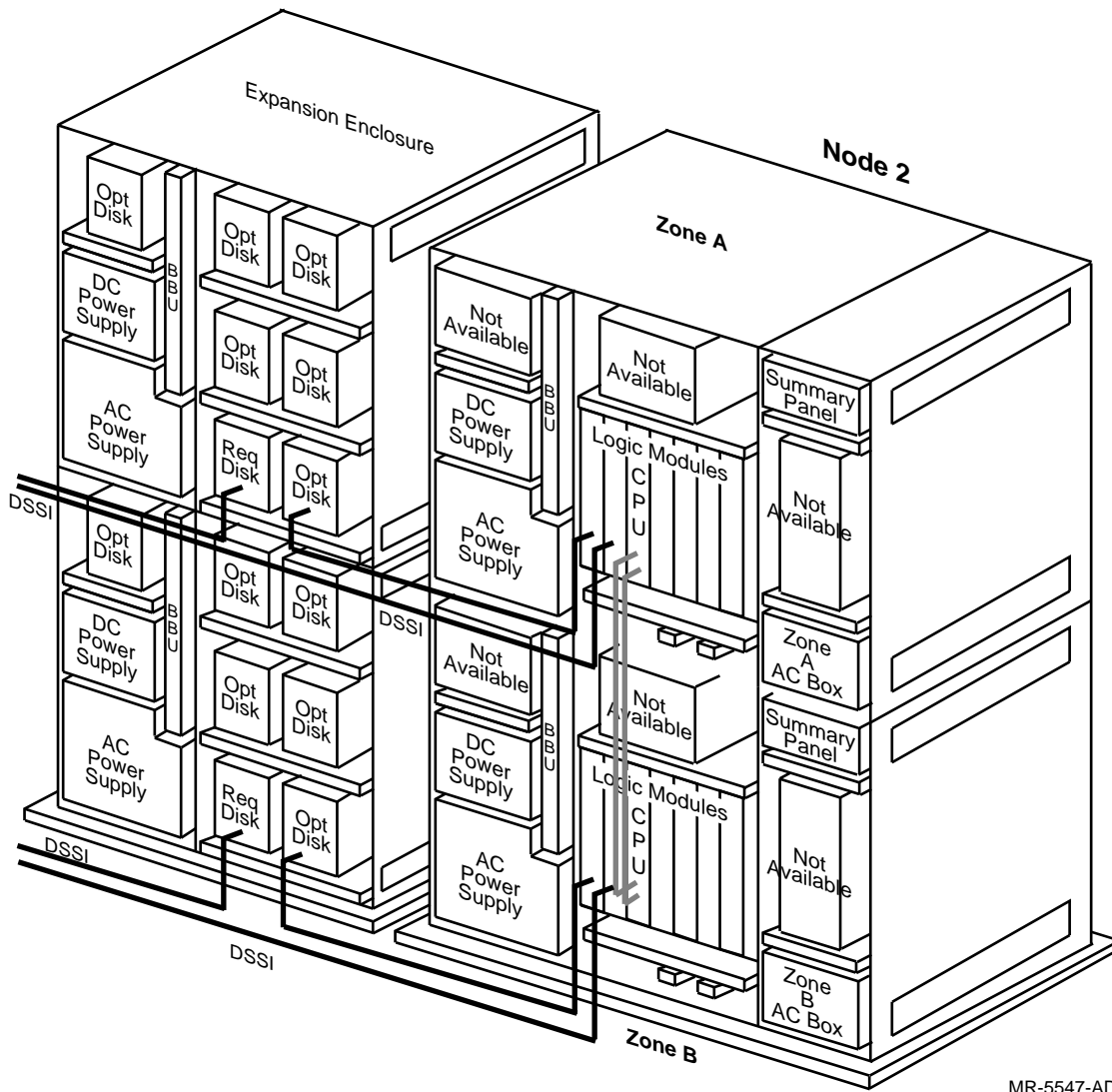

Figure 2-9 VAXft Model 612 VAXcluster with Storage Expansion



MR-5546-AD



MR-5547-AD

Table 2-9 gives the system components available for the Model 612 VAXcluster system with storage expansion.

Table 2-9 Options for the Model 612 VAXcluster System with Storage Expansion

Option	Description
TF70C/TF85C Tape Drive	Optional; a maximum of two tape drives can be configured in Node 1.
TF857 Tape Loader	Optional; a tape loader can replace one or both tape drives.
RF31/RF72 Disks	A minimum of four fixed disks is required. A maximum of 24 disks can be configured, 12 disks per expansion cabinet. Two removable disks per expansion cabinet can replace two fixed disks.
MS520 Memory Module	A maximum of four memory modules per zone per node can be configured.
KFE32 System I/O Controller Module	The system comes with two system I/O controllers in each zone in each node for DSSI and Ethernet connections. Up to two additional modules can be configured in each zone in each node to provide additional connections to Ethernet lines.
DSF32 DEC WANcontroller 620	A maximum of six WAN modules (three per zone) can be configured to give 12 synchronous nonredundant lines per node and a total of 24 per VAXcluster system.

Communications

As the industry leader in networking, Digital Equipment Corporation provides communications options to enable VAXft systems to be configured in Local Area Networks (LANs) using Ethernet connections and Wide Area Networks (WANs) using the DEC WAN controller 620.

3.1 Ethernet Connections

The ability to connect to the Ethernet enables VAXft systems to use certain networking options available from Digital Equipment Corporation. Ethernet, the industry standard Local Area Network, enables VAXft systems to communicate with other computers in your enterprise.

VAXft systems support redundant connections to a single Ethernet or to multiple Ethernets. The Ethernet interface is in the system I/O controller module. This module supports both thick wire and ThinWire connections between the system and Ethernet.

Figure 3-1 shows two connections to a single Ethernet, one connection from each zone of the system.

Figure 3–1 System Connected to a Single Ethernet

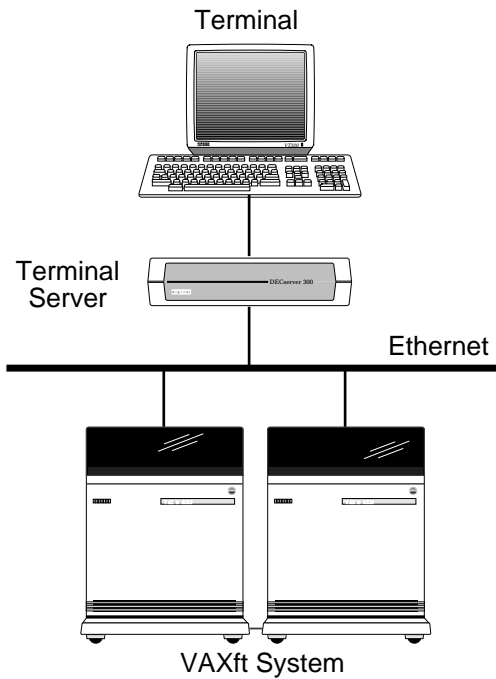

MR-5519-AD

To ensure access to Ethernet even if one connection is not working, you can configure redundant connections to multiple Ethernets, as shown in Figure 3–2. You can use up to four system I/O controller modules in each zone for a total of eight controllers system-wide. Thus, there is at least one I/O module in each zone connected to each Ethernet at all times. Refer to the *Networks and Communications Buyer's Guide* for further details on Ethernet options.

Figure 3-2 System Connected to Dual Ethernet

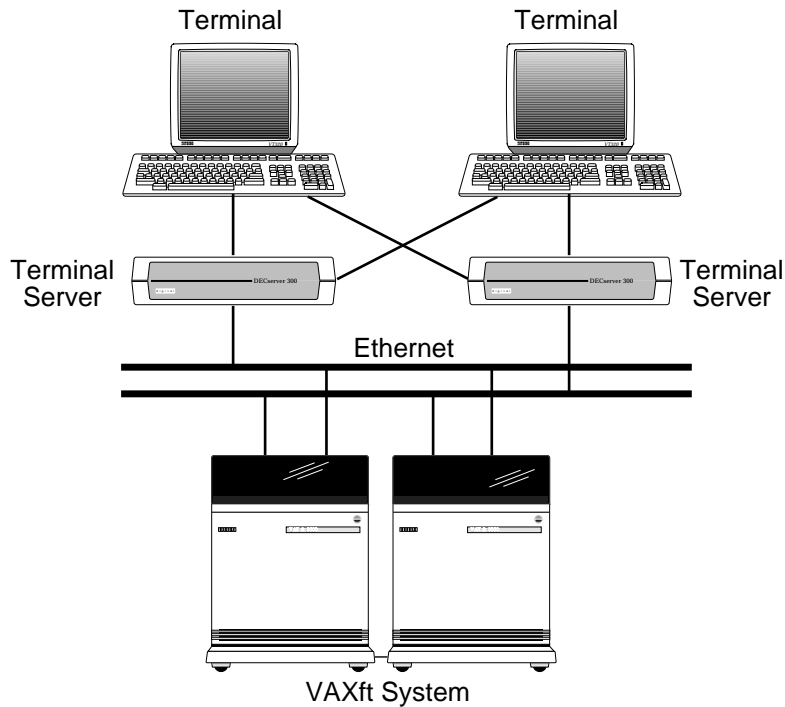

MR-5520-AD

3.1.1 DECserver Terminal Servers

Terminal servers provided by Digital Equipment Corporation for use with VAXft systems include a variety of DECserver systems to provide asynchronous communications.

Terminal servers provide system users with easy, transparent access to VAXft system resources. Figures 3-1 and 3-2 illustrate how terminal servers are used to connect user terminals to the system through the Ethernet. Terminal servers enable users to establish and maintain several simultaneous sessions on system processors without delay, as long as sufficient resources are available. Figure 3-2 shows how the terminals as well as the servers can be configured redundantly so that a user can switch to another server if one goes down. To switch between servers, the user will need a dual-session terminal, such as a VT320, with a line to each server.

3.1.2 Ethernet Communications Servers

Expanded synchronous communications are supported through Ethernet-based Gateways or Microservers. An example of such as server is the DEC Commserver 100/150. This server supports a VAXft system with special communications protocols (Q-bus Simpack Associates). It allows up to 80 synchronous/asynchronous serial lines to be connected to the Ethernet at up to 14 kilobytes per second. The 14 industry protocols supported on these lines have different performance specifications and the actual number of lines depends on the type of protocol and the line speed. The DEC Commserver software provides transparent connection between the DEC Commserver hardware and the VAXft system. Redundant connections to the Ethernet can provide failover, and two DEC Commservers can provide redundant dual-path subsystems to the required communications systems.

For more information on communications servers used with the VAXft systems, see the *VAX Systems/DECsystems Systems and Options Catalog* and the *Networking and Communications Buyers Guide*.

3.2 DEC WANcontroller 620

The DEC WANcontroller 620 is a two-line synchronous communication controller option specifically designed for VAXft systems. The WAN module can be configured to provide highly-available synchronous communication. Depending upon the model, VAXft systems can support up to four WAN modules in each zone (eight per system). Each module contains two lines; thus, eight redundant or 16 nonredundant synchronous lines can be supported by a single VAXft system, with full modem control. Lines attached to redundant controllers are connected by Y-connectors that enable a single synchronous line to be connected to an adapter in each zone, as shown in Figure 3-3.

Figure 3-3 Synchronous Communication Lines Using Y-Connectors

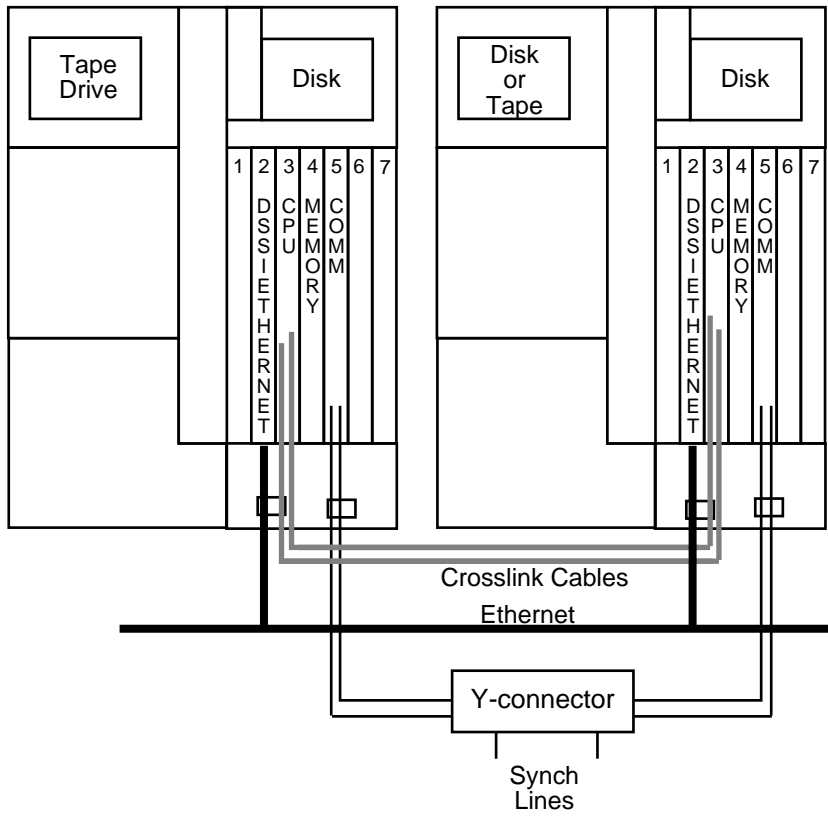

MR-5522-AD

System Service and Warranty

The VAXft systems service and repair features and warranties are described in this chapter.

4.1 Service and Repair Features

The VAXft systems' design makes them easier to repair and maintain than other types of fault-tolerant computers.

The dual zone design enables repairs without interruption to a running application because the system's redundant hardware enables the operational zone to continue to service the application while repairs are made to the zone that has been shut down. Each zone displays a flashing red light to identify a failure in the zone. Logic modules have Magnetic Fault Indicators (MFI) that provide visual indication of a fault. The system's modular system design makes repair as easy as manually removing the *Field Replaceable Unit* (FRU) and replacing it with a new unit.

All the components of each cabinet are accessible from the front. Dual doors allow easy operator access.

To expedite repairs even further, the system can automatically notify a destination of your choice by automatic dial-out notification.

Automatic dial-out notification is Digital Equipment Corporation's proactive approach to resolving system problems before they lead to failures.

Depending on your requirements, automatic dial-out notification can send a message to an operator on site or to a remote terminal using a predefined telephone number and a modem. To have this feature available, you must have System Directed Diagnosis Version 1.6 and DSNlink Version 1.1-1. Additional features can be added to automatically place a service call to a Digital Service Center when a system is experiencing a problem or the system exceeds a predictive maintenance threshold.

When you combine all of these features, you can be sure that VAXft systems provide the fastest and most accurate repair and service available for any fault-tolerant computer system today.

4.2 System Warranty

The following warranties are available for VAXft systems:

- Standard Warranty
- List Warranty

4.2.1 Standard Warranty

The standard warranty available for VAXft systems includes:

- Hardware installation
- One-year DECservice for hardware, 24-hour, 7-day a week coverage, including holidays, with a committed response time
- Telephone assistance for hardware, operating system software, and Digital layered products purchased with the Standard Warranty
- Critical on-site software support
- Digital Software Information Network
- Right-to-use new versions of software
- Product Foundation Warranty for kernel software

4.2.2 List Warranty

The List Warranty available for VAXft systems includes a 1-year return to factory for all hardware and software conformance.

4.3 Digital Assisted Services Program

The Digital Assisted Services Program (DASP), which provides self-maintenance customers with selected products and services under an annuity payment schedule, is available for VAXft systems.

The DASP is a four-part program that includes:

- Diagnostics and documentation
This includes licensing of diagnostics, media and documentation kits for diagnostics, hardcopy manuals and print sets, maintenance documentation service (including DEC-O-Log), and rights-to-copy.

- **Diagnostic and documentation updates**
This includes media and documentation kits, microfiche for hardcopy documentation, and rights-to-copy.
- **DECmailer and Field Change Orders**
This includes DECmailer Plus board repair for a 24-hour turnaround time, emergency dispatch service at no extra charge, all repairable boards accepted regardless of revision, unlimited number of boards repaired. Field Change Orders include the same services as DECservice customer and materials only customer installations.
- **Customer Support Centers**
Customer Support Centers provide 24-hour, 7-day a week, access to remote diagnostic and remote support groups. In addition, use of service delivery tools, such as VAXsimPlus and SPEAR, is included.

A subscriber to DASP can also purchase spare parts and kits, internal customer services training, and backup support on a per call basis.

Glossary

The following is a list of terms commonly used in this guide.

automatic dial-out notification

The process of sending a message to a specific remote site using a modem and a predefined telephone number to alert personnel of a system fault or failure.

autonotification

Automatic dial-out notification.

availability

The likelihood that the system will be operable when you require it to perform a task.

boot or bootstrap

The process of loading system software into a processor's main memory.

crosslink

The cable that connects two VAXft zones together to form a fault-tolerant system.

DEC WANcontroller 620

Digital Equipment Corporation's Wide Area Network controller for VAXft systems.

DMA

Direct Memory Access. The hardware that transfers data between VAXft main memory and the buffer memory on the I/O modules.

DSSI

A data bus that uses the System Communication Architecture (SCA) protocols for direct host-to-storage communications. The DSSI cable can extend to six meters and has a peak bandwidth of four megabytes.

error

An incorrect response from a hardware module. An error can lead to a system failure in non fault-tolerant systems. An error is a manifestation of a fault. See *fault*.

failover

The reconfiguration process that a fault-tolerant system undergoes to remain operational after it experienced a failure or partial shutdown for planned maintenance.

Failover Set Manager (FSM)

A VAXft System Services utility that ensures fault-tolerant access to I/O, for example, the Ethernet. It permits users to manipulate the membership of failover sets of redundant physical Ethernet adapters by adding or removing them, or by changing their status.

failure

Any system behavior that deviates from the system's specifications. In regard to the VAXft systems, failure often refers to a failed hardware component, such as a CPU or memory module.

fault

A condition existing in hardware or software that can lead to system failure. Typically, physical conditions such as worn-out modules, external or environmental problems, design flaws, or manufacturing defects can cause hardware faults. Software design flaws or implementation errors can cause software faults.

fault tolerant system

Fault tolerance is the degree to which a computer system maintains its reliability and availability. A computer system that tolerates any single point of failure and continues to provide virtually uninterrupted service to an application is a fault-tolerant system.

FRU

Field Replaceable Unit. A unit designed to be replaced in the field by appropriate personnel.

lockstep

Simultaneous execution of the same instruction stream by the two CPU modules in a VAXft system running in a synchronized, dual-zone configuration.

parallel crosslink

The portion of the crosslink used to communicate between system zones when the system is running in lockstep operation.

PCM

Power and Cooling Monitor.

reliability

The likelihood that a system or system component will continue to function over a given time period.

redundancy

Duplication of elements or components to provide alternative functional channels in case of single component failures.

shadow set

Several physical disk drives, known as *shadow set members*, that are associated with a software-created virtual unit for volume shadowing.

system disk

The disk that contains the VMS operating system.

system I/O controller module

VAXft I/O module. The I/O module contains Ethernet ports, DSSI bus communications, and system console ports.

VAXft System Services

A VMS layered product required to use a VAXft system as a fault-tolerant system.

VAXcluster system

A loosely coupled, highly integrated, distributed computing environment. There are four types of VAXcluster system configurations, depending on the medium used for interprocessor communications: CI-based, local-area (Ethernet-based), DSSI-based (VAXft Model 612 system), and mixed-interconnect VAXcluster systems.

volume shadowing

An implementation of disk shadowing in which duplication of data to more than one volume is controlled through software that can reside on a central server host in a local area VAXcluster system. It provides increased data integrity and high availability to VAXft systems.

Y-connector

Hardware that joins two synchronous communication lines into a single output line.

zone

A section of a fully-configured VAXft system that contains a minimum of a CPU module, memory module, I/O module, and associated devices. A fault-tolerant system consists of two such zones with synchronized processor operations. If one zone fails, processing continues uninterrupted through automatic failover to the other zone.

Index

A

Asynchronous communications, 1-7
Automatic dial-out notification, 4-1
Autonotification, 1-12, 4-1

B

Backplane, 1-4
 five-slot, 1-5 (fig)
 seven-slot, 1-4 (fig)
Base system
 Model 110, 2-4
 Model 310/410, 2-5
 Model 610, 2-10
 Model 612 VAXcluster, 2-17

C

Communications, 3-1
 Asynchronous, 1-7
 DEC WANcontroller 620, 1-8, 3-4
 Ethernet, 3-1
 synchronous, 3-4
 Synchronous (Ethernet), 1-7
 Y-connector, 3-4 (fig.)
Communication servers
 Ethernet, 3-4
Configuration
 Ethernet, 3-1
 Model 110 system, 2-4, 2-5 (fig.)
 Model 310/410 base system, 2-5, 2-6 (fig.)

Configuration (Cont.)

 Model 310/410 expanded system, 2-7, 2-7 (fig.)
 Model 610 base system, 2-10, 2-10 (fig.)
 Model 610 expanded systems, 2-12
 Model 610 with dual expander, 2-14 (fig.)
 Model 610 with single expander, 2-12 (fig.)
 Model 612 VAXcluster base system, 2-17, 2-17 (fig.)
 Model 612 VAXcluster expanded system, 2-17, 2-20 (fig.)
Console terminals, 1-7
CPU module, 1-5
Crosslink, 1-4, 1-6

D

DASP (Digital Assisted Services Program), 4-2
DEC Commserver 100/150, 1-7, 3-4
DECnet-VAX end-node license, 1-9
DECnet-VAX full function license, 1-9
DECserver terminal servers, 3-3
DEC WANcontroller 620, 1-8, 3-4
 options, 2-1
Digital Customer Services, 4-1
Disks
 fixed, 2-2
 removable, 2-2
DSNlink, 4-1
DSSI, 1-7
 options, 2-1
DSSI-based VAXcluster system, 1-7
Dual Ethernet connections, 3-2 (fig.)

Dual-session terminal, 3-3
Dual zones, 1-2

E

Environmental monitor, 1-12
Ethernet, 1-7
 communications, 3-1
 communication servers, 3-4
 configurations, 3-1
 dual, 3-2 (fig.)
 options, 2-1
 single, 3-1 (fig.)
Ethernet-based VAXcluster systems, 1-7
Expanded system
 Model 310/410, 2-7
 Model 610, 2-12
 Model 612 VAXcluster, 2-17

F

Five-slot backplane, 1-5 (fig.)
Fixed disks, 2-2
 replacing, 2-2, 2-3 (fig.)
FRU (Field Replaceable Unit), 4-1
FSM (Failover Set Manager) Utility
 overview, 1-10
FTSS\$CONTROL Utility, 1-10

L

LAN (Local Area Networks), 1-7
Licenses
 software, 1-9
Local Area Network (LAN), 1-7
Lockstep, 1-3

M

Mass storage
 options, 2-1, 2-2
Memory, 1-6
 options, 2-1
MFI (Magnetic Fault Indicators), 4-1
Model 110 system, 2-4
 options, 2-4

Model 110 VUPs, 1-6
Model 310/410 base system, 2-5
 options, 2-5
Model 310/410 expanded system, 2-7
 options, 2-7
Model 310 VUPs, 1-6
Model 410 VUPs, 1-6
Model 610 base system, 2-10
 options, 2-10
Model 610 expanded systems, 2-12
Model 610 VUPs, 1-6
Model 610 with dual expander
 options, 2-16
Model 610 with single expander
 options, 2-12
Model 612 VAXcluster base system, 2-17
 options, 2-17
Model 612 VAXcluster expanded system,
 2-17
 options, 2-22
Model 612 VUPs, 1-6
Module slots, 1-4

N

Networks
 Local Area, 1-7

O

Options
 DEC Wancontroller 620, 2-1
 DSSI, 2-1
 Ethernet, 2-1
 mass storage, 2-1, 2-2
 memory, 2-1
 Model 110 system, 2-4
 Model 310/410 base system, 2-5
 Model 310/410 expanded system, 2-7
 Model 610 base system, 2-10
 Model 610 with dual expander, 2-16
 Model 610 with single expander, 2-12
 Model 612 VAXcluster base system, 2-17
 Model 612 VAXcluster expanded system,
 2-22

P

PCM (Power and Cooling Monitor), 1-12
Power subsystem, 1-11

R

Redundant Ethernet connections, 1-7
Redundant terminals, 3-3
Removable disks, 2-2
Repair, 4-1
Replacing fixed disks with removable disks,
2-2, 2-3 (fig.)
Replacing fixed disks with tapes, 2-2, 2-3
(fig.)

S

Servers
communication (Ethernet), 3-4
Seven-slot backplane, 1-4 (fig.)
Single Ethernet connection, 3-1 (fig.)
Single point of failure, 1-1
Single point of repair, 1-1
Software licenses, 1-9
Synchronous communications, 1-8, 3-4
DEC WANcontroller 620, 1-8
Ethernet, 1-7
System architecture, 1-2
dual zones, 1-2
System Directed Diagnosis (SDD), 4-1
System hardware, 1-4
logical design, 1-2 (fig.)
System I/O controller, 1-6
System software, 1-8

T

Terminals
console, 1-7
Terminal servers
DECserver, 3-3
redundant, 3-3

U

UPS (Uninterruptible Power Supply), 1-1,
1-11

V

VAXcluster system
DSSI-based, 1-7
VAXft Model 612, 1-7
VAXft Model 612 VAXcluster system, 1-7
VAXft System Services, 1-10
VMS operating system, 1-9
VMS Volume Shadowing, 1-9
guidelines, 1-9
VUPs
Model 110, 1-6
Model 310, 1-6
Model 410, 1-6
Model 610, 1-6
Model 612, 1-6

W

Warranty
Digital Assisted Services Program, 4-2
list, 4-2
standard, 4-2

Y

Y-connector, 3-4