

# **HA3000 20-80 kVA Uninterruptible Power System Installation Manual**

Order Number EK-HA32X-IN-002

**November 1991**

The information in this document is subject to change without notice and should not be construed as a commitment by Digital Equipment Corporation. Digital Equipment Corporation assumes no responsibility for any errors that may appear in this document.

Possession, use, duplication, or dissemination of the software described in this documentation is authorized only pursuant to a valid written license from Digital or the third-party owner of the software copyright.

No responsibility is assumed for the use or reliability of software on equipment that is not supplied by Digital Equipment Corporation.

Copyright © Digital Equipment Corporation 1991

All Rights Reserved.  
Printed in U.S.A.

The postpaid Reader's Comment Card included in this document requests the user's critical evaluation to assist in preparing future documentation.

**FCC NOTICE:** The equipment described in this manual generates, uses, and may emit radio frequency energy. The equipment has been type tested and found to comply with the limits for a Class A computing device pursuant to Subpart J of Part 15 of FCC Rules, which are designed to provide reasonable protection against such radio frequency interference when operated in a commercial environment. Operation of this equipment in a residential area may cause interference, in which case the user at his own expense may be required to take measures to correct the interference.

The Digital logo is a trademark of Digital Equipment Corporation.

This document was prepared and published by Educational Services Development and Publishing, Digital Equipment Corporation.

# Contents

---

<b>About This Manual</b>	ix
--------------------------	----

## **1 INSTALLATION REFERENCE CHECKLISTS**

1.1	CUSTOMER RESPONSIBILITIES	1-1
1.1.1	Site Preparation	1-1
1.1.2	Delivery/Handling	1-2
1.2	TRUCKER/MOVER/RIGGER RESPONSIBILITIES	1-3
1.3	ELECTRICIAN RESPONSIBILITIES	1-3
1.3.1	HA32A UPS Cabinet	1-3
1.3.2	HA32B UPS Battery Cabinet	1-4
1.3.3	HA32C/D/E UPS Auxiliary Cabinet	1-5
1.3.4	HA33D/F UPS CSA Cabinet	1-6
1.3.5	HA32J/K UPS Distribution Cabinet	1-7
1.3.6	HA320-A3 Remote Alarm Panel	1-8
1.4	DIGITAL SERVICES RESPONSIBILITIES	1-9
1.4.1	Site Preparation	1-9
1.4.2	Delivery/Handling	1-10
1.4.3	Initial Startup	1-10

## **2 SITE PREPARATION**

2.1	GENERAL	2-1
2.2	STORAGE	2-1
2.3	HA32A UPS CABINET	2-2
2.4	HA32B UPS BATTERY CABINET	2-6
2.4.1	Environmental Considerations	2-6
2.4.2	Mechanical Considerations	2-6
2.5	HA32C/D/E UPS AUXILIARY CABINET	2-8
2.6	HA33D/F UPS CSA CABINET	2-10
2.7	HA32J/K UPS DISTRIBUTION CABINET	2-12

### 3 HA3000 UPS RECEIVING AND HANDLING

3.1	GENERAL .....	3-1
3.2	RECEIVING .....	3-1
3.3	HANDLING .....	3-2
3.3.1	Removing Unit from Truck .....	3-3
3.3.2	Removing Shipping Carton .....	3-3
3.3.3	Removing Unit from Pallet .....	3-3
3.3.4	Recommended Layout .....	3-4
3.3.5	Moving Unit to Final Position .....	3-5
3.3.6	Caster Removal .....	3-5

### 4 INSTALLATION

4.1	GENERAL .....	4-1
4.2	HA32A UPS Cabinet .....	4-1
4.2.1	Main AC Input (MAINS1) Connection .....	4-2
4.2.2	Bypass AC Input (MAINS2) Connection .....	4-4
4.2.3	UPS Output Load Connection .....	4-4
4.2.4	Battery Connection .....	4-4
4.2.5	UPS Battery Cabinet Control Wire Connections (TB1) .....	4-5
4.2.5.1	Battery Cabinet Circuit Breaker (QF1) Control Wiring .....	4-6
4.2.5.2	DC Ground Fault Detector Control Wiring .....	4-6
4.2.5.3	Smoke Detector Control Wiring .....	4-6
4.2.6	Contact Closure Control Wire Connections (TB2) .....	4-7
4.2.7	Remote Status Panel and Remote Alarm Panel Control Wire Connections (TB3) .....	4-7
4.2.7.1	Remote Status Panel Control and Power Wire Connections .....	4-7
4.2.7.2	Remote Alarm Panel Control and Power Wire Connections .....	4-8
4.2.8	Checks After Installation .....	4-8
4.3	HA32B UPS BATTERY CABINET .....	4-9
4.3.1	General Installation .....	4-9
4.3.2	Single UPS Battery Cabinet/HA32A UPS Installation .....	4-10
4.3.3	Two UPS Battery Cabinets/HA32A UPS Installation .....	4-11
4.3.4	Power Cable Connections .....	4-11
4.3.5	Control Wire Connections .....	4-12
4.3.6	Interbattery Link Connection .....	4-12
4.3.7	Checks After Installation .....	4-12
4.3.8	Reassembling the UPS Battery Cabinet .....	4-13
4.4	HA32C/D/E UPS AUXILIARY CABINET .....	4-14
4.4.1	Power Cable Connections .....	4-16
4.4.1.1	AC Input Connection for Input Isolation Transformer Option .....	4-16
4.4.1.2	Connecting the Isolation Transformer for Both the UPS Main AC Input (MAINS1) and Bypass AC Input (MAINS2) .....	4-19
4.4.1.3	Connecting the Isolation Transformer for the UPS Bypass AC Input (MAINS2) Only .....	4-20

4.4.1.4	Connecting the Isolation Transformer for the UPS Main AC Input (MAINS1) Only	4-21
4.4.1.5	Connecting the Input Harmonic Current Filter	4-21
4.4.2	Control/Interface Wiring	4-23
4.4.3	Checks After Installation	4-23
4.5	HA33D/F UPS CSA CABINET	4-24
4.5.1	Power Cable Connections	4-26
4.5.1.1	Connecting the HA33D with Input Isolation/Step-Down Transformer and CSA Assembly	4-26
4.5.1.2	Connecting the HA33F with CSA Assembly Only	4-27
4.5.2	Control/Interface Wiring	4-29
4.5.3	Checks After Installation	4-29
4.6	HA32J/K UPS DISTRIBUTION CABINET	4-30
4.6.1	Power Cable Connections	4-31
4.6.1.1	AC Input Connection Without Isolation/Step-Down Transformer	4-31
4.6.1.2	AC Input Connection With Isolation/Step-Down Transformer	4-31
4.6.2	Control/Interface Wiring	4-32
4.6.3	Installation and Connection of Optional Digital Output Cables	4-32
4.6.3.1	Output Circuit Breaker Installation	4-32
4.6.3.2	Output Cable Installation	4-35
4.6.4	Non-Digital Output Cables	4-35
4.6.5	Checks After Installation	4-36
4.7	HA320-AA/AB REMOTE STATUS PANEL	4-37
4.8	HA320-A3 REMOTE ALARM PANEL	4-38
4.9	HA320-C2 DC GROUND FAULT DETECTOR	4-39
4.10	HA320-B1 SMOKE DETECTOR	4-40

## A ELECTRICAL CONSIDERATIONS

A.1	GENERAL	A-1
A.2	TERMS AND DEFINITIONS	A-1

## B SPECIFICATIONS

### Index

### Figures

2-1	Right-Side Cable Access for the UPS Cabinet	2-2
2-2	Bottom View, 20 and 40 kVA Models	2-3
2-3	Bottom View, 60 and 80 kVA Models	2-4
2-4	Floor Tile Cutout	2-6
2-5	UPS Auxiliary Cabinet Placement	2-8
2-6	UPS CSA Cabinet Placement	2-10
2-7	UPS Cabinet and UPS Distribution Cabinet Placement	2-12

2-8	UPS Cabinet, UPS Auxiliary Cabinet or UPS CSA Cabinet, and UPS Distribution Cabinet Placement . . . . .	2-13
3-1	Handling the HA3000 Series Cabinets . . . . .	3-2
3-2	HA3000 Series UPS Layout . . . . .	3-4
4-1	UPS Cabinet Power Wiring Connections . . . . .	4-2
4-2	Yellow Jumper Tag . . . . .	4-4
4-3	UPS Cabinet Control Wiring Connections . . . . .	4-5
4-4	UPS Battery Cabinet Power and Control Wiring Connections . . . . .	4-11
4-5	UPS Auxiliary Cabinet Mounting Holes . . . . .	4-14
4-6	Right Side Cable Entry Area . . . . .	4-15
4-7	UPS Auxiliary Cabinet Cable Trays . . . . .	4-16
4-8	Connecting the Isolation Transformer . . . . .	4-19
4-9	UPS Input and Bypass Input Isolation Transformer Configuration . . . . .	4-20
4-10	UPS Bypass Input Isolation Transformer Configuration . . . . .	4-20
4-11	Alternate UPS Bypass Input Isolation Transformer Configuration . . . . .	4-21
4-12	UPS Input Isolation Transformer Configuration . . . . .	4-21
4-13	UPS Cabinet Without Input Harmonic Current Filter Installed . . . . .	4-22
4-14	UPS Cabinet with Input Harmonic Current Filter Installed . . . . .	4-23
4-15	UPS CSA Cabinet Mounting Holes . . . . .	4-24
4-16	Right Side Cable Entry Area . . . . .	4-25
4-17	HA33D UPS CSA Cabinet Wiring Diagram . . . . .	4-27
4-18	HA33F UPS CSA Cabinet Wiring Diagram . . . . .	4-28
4-19	UPS Distribution Cabinet Mounting Holes . . . . .	4-30
4-20	Square-D Distribution Panelboard . . . . .	4-33
4-21	Bryant Distribution Panelboard . . . . .	4-34

## Tables

2-1	Standard HA32A UPS Models . . . . .	2-5
2-2	UPS Battery Cabinet Model Numbers . . . . .	2-7
2-3	UPS Auxiliary Cabinet Weights and Dimensions . . . . .	2-9
2-4	UPS CSA Cabinet Weights and Dimensions . . . . .	2-11
2-5	UPS Distribution Cabinet Specifications . . . . .	2-14
4-1	HA32A Currents . . . . .	4-3
4-2	Maximum DC Current Requirements . . . . .	4-9
4-3	Interbattery Link Torque Values . . . . .	4-12
4-4	HA32C/D/E UPS Auxiliary Cabinet Electrical Specifications . . . . .	4-17
4-9	HA33D/F UPS CSA Cabinet Electrical Specifications . . . . .	4-26
B-1	Standard HA32A UPS Models . . . . .	B-4
B-2	HA32A Currents . . . . .	B-5
B-3	UPS Battery Cabinet Model Numbers . . . . .	B-6
B-4	Maximum DC Current Requirements . . . . .	B-6
B-5	Interbattery Link Torque Values . . . . .	B-7
B-6	UPS Auxiliary Cabinet Weights and Dimensions . . . . .	B-7
B-7	HA32C/D/E UPS Auxiliary Cabinet Electrical Specifications . . . . .	B-8
B-8	UPS CSA Cabinet Weights and Dimensions . . . . .	B-10
B-9	HA33D/F UPS CSA Cabinet Electrical Specifications . . . . .	B-10

**B-10 UPS Distribution Cabinet Specifications . . . . . B-11**





# About This Manual

---

## OVERVIEW

This manual is intended for use by the customer for site preparation, by the customer's electrician to install the HA3000 20-80 kVA series Uninterruptible Power System (UPS), and by the Digital Services Engineer to ensure proper installation before performing the startup procedures. It provides site preparation information and instructions for receiving, handling, storing, and installing the UPS for the customer and the customer's electrician. **The installation must be completed before calling Digital Services to perform the startup procedures. Incomplete installation will result in startup delays.**

## WARNING

**The HA32B UPS Battery Cabinet contains batteries that are wired together to produce a high voltage. Even with no external connections, hazardous voltage exists inside the UPS Battery Cabinet that can cause severe burns or death upon contact.**

The manual covers the following topics:

- Chapter 1 contains a checklist of the responsibilities of the customer, customer's electrician, trucker/mover/rigger, and Digital Services during site preparation, delivery/handling, installation, and startup of the HA3000 series UPS.
- Chapter 2 contains site preparation information for the HA32A UPS cabinet, the HA32B UPS Battery Cabinet, the HA32C/D/E UPS Auxiliary Cabinet, the HA33D/F UPS CSA Cabinet, and the HA32J/K UPS Distribution Cabinet.
- Chapter 3 contains information for receiving and handling the HA3000 series equipment cabinets.
- Chapter 4 contains the installation procedures for the HA32A UPS cabinet, the HA32B UPS Battery Cabinet, the HA32C/D/E UPS Auxiliary Cabinet, the HA33D/F UPS CSA Cabinet, the HA32J/K UPS Distribution Cabinet, the HA320-AA/AB Remote Status Panel, the HA320-A3 Remote Alarm Panel, the HA320-B1 Smoke Detector, and the HA320-C2 DC Ground Fault Detector.
- Appendix A contains electrical considerations for the HA32A UPS cabinet.
- Appendix B contains specification tables for the HA3000 series components.

## RELATED DOCUMENTS

<b>Title</b>	<b>Part Number</b>
<i>HA3000 20-80 kVA Uninterruptible Power System User Guide</i>	EK-HA32X-UG
<i>HA3000 20-80 kVA Uninterruptible Power System Installation Drawings</i>	EK-HA32X-ID
<i>HA3000 Uninterruptible Power System Handling Instructions</i>	EK-HA32X-HI
<i>HA3000 Uninterruptible Power System Technical Manual</i>	EK-HA32X-TM

## INSTALLATION REFERENCE CHECKLISTS

### 1.1 CUSTOMER RESPONSIBILITIES

The following sections contain checklists of the responsibilities of the customer during site preparation and delivery/handling of the HA3000 series UPS.

#### 1.1.1 Site Preparation

The customer's responsibilities during site preparation are listed below.

Check Off	Function	Task
<input type="checkbox"/>	Electrical Connections	Obtain an electrician to perform the electrical connections that are described in Chapter 4.
<input type="checkbox"/>	Site Selection	Select the area where the HA3000 series UPS will be installed. Where it is located will have a bearing on the electrical installation cost and installation time.  <b>NOTE:</b> It is highly recommended that the HA3000 series UPS be installed in a computer room environment with a raised floor.
<input type="checkbox"/>	Physical Size and Weight	Obtain the size and weight information on the HA3000 series cabinets that are to be installed. Refer to the <i>HA3000 20-80 kVA Uninterruptible Power System Installation Drawings</i> (EK-HA32X-ID) or to Chapter 2 in this manual.
<input type="checkbox"/>	Physical Placement	Determine the exact physical placement of the cabinets. The cabinet dimensions and service clearances must be taken into consideration. The following is a list of the <b>minimum</b> service clearances required.  Rear - 60.96 cm (24 in) Front - 121.92 cm (48 in) Side - 60.96 cm (24 in) on each end of the cabinet configuration Top - 91.44 cm (36 in)  <b>NOTE:</b> Local codes may require more clearance.
<input type="checkbox"/>	Floor Loading	Ensure that the floor can support the total configuration weight. If there is any question in this regard, a structural engineer should be consulted.

## 1-2 INSTALLATION REFERENCE CHECKLISTS

Check Off	Function	Task
<input type="checkbox"/>	Configuration Layout	Plan the configuration layout using the following placement order (left to right): UPS Battery Cabinet(s), UPS cabinet, UPS Auxiliary Cabinet, UPS CSA Cabinet, and UPS Distribution Cabinet.
<input type="checkbox"/>	Floor Marking	Mark the outside dimensions of the cabinet configuration and the floor cutouts on the floor with tape so that placement and any floor cutouts will be in the correct place.
<input type="checkbox"/>	Floor Cutouts	On a raised floor, ensure that floor tile cutouts are provided for cool air supply and cabling. Refer to the <i>HA3000 20-80 kVA Uninterruptible Power System Installation Drawings</i> (EK-HA32X-ID) for the cable entry areas on the UPS cabinet, the UPS Battery Cabinet, and the UPS Distribution Cabinet.  <b>CAUTION:</b> If perforated tiles are used for cooling, ensure that air restricting baffles are not installed beneath them.
<input type="checkbox"/>	Inside Delivery Route	Ensure that there is an unobstructed inside delivery path to the final installation position. Ensure that elevators, ramps, and flooring along this path can handle the equipment weights and dimensions.

### 1.1.2 Delivery/Handling

The customer's responsibilities during delivery/handling are listed below.

Check Off	Function	Task
<input type="checkbox"/>	Site Delivery Coordination	Assist Digital Services in assuring proper delivery and placement of the HA3000 series cabinets.
<input type="checkbox"/>	Configuration Assembly	Assist Digital Services in removing the appropriate side skins and cover plates before the cabinets are in their final position.
<input type="checkbox"/>	Final Assembly	Assist Digital Services in replacing all exterior skins. Check to ensure that all cabinets are complete.

## 1.2 TRUCKER/MOVER/RIGGER RESPONSIBILITIES

The trucker/mover/rigger's responsibilities during delivery/handling are listed below.

Check Off	Function	Task
<input type="checkbox"/>	Inside Delivery and Handling	Deliver the HA3000 series cabinets from the padded van to the final resting place at the customer's site. Follow the handling instructions in Chapter 3.
<input type="checkbox"/>	Caster Assembly Removal	Remove the yellow caster assemblies beneath each cabinet after the cabinets have been moved to their final resting place.

## 1.3 ELECTRICIAN RESPONSIBILITIES

The following sections contain the responsibilities of the electrician during the installation of the HA3000 series UPS. The electrician should refer to the *HA3000 20-80 kVA Uninterruptible Power System Installation Drawings (EK-HA32X-ID)* and to the procedures in Chapter 4 when performing the actual installation. All electrical site wiring must comply with the National Electrical Code (ANSI/NFPA 70) and with local codes as applicable.

### 1.3.1 HA32A UPS Cabinet

The electrician's responsibilities during the installation of the HA32A-xx UPS cabinet are listed below.

Check Off	Function	Task
<input type="checkbox"/>	Cable Entry/Exit	Perform the cable knockouts and provide the fittings and conduits for this cabinet. Bottom or right-side cable entry is possible. Refer to Figure 2-1, Figure 2-2, and Figure 2-3.
<input type="checkbox"/>	Input Conductor Sizing	Determine the input conductor sizing for the UPS. The circuit rating needs to be matched to the input circuit breaker for the unit being installed. Refer to Table 2-1 for the input circuit breaker ratings for the different UPS models.
<input type="checkbox"/>	MAINS1 Input Conductors (supplied by the electrician)	Provide four wires for the MAINS1 input; three phase conductors and a ground. If only one power source is to be used for the MAINS1 and MAINS2 inputs, the MAINS1 and MAINS2 busbars must be jumpered together using the correct gauge wire.
<input type="checkbox"/>	MAINS2 Input Conductors (supplied by the electrician)	Provide five wires for the MAINS2 input; three phase conductors, a neutral <sup>1</sup> (all four of equal ampacity), and a ground. If only one power source is to be used for the MAINS1 and MAINS2 inputs, the MAINS1 and MAINS2 busbars must be jumpered together using the correct gauge wire. If no neutral <sup>1</sup> is available from the building distribution system (for example, DELTA only service entrance), a UPS Auxiliary Cabinet with an input isolation transformer may be used to derive a neutral for the UPS cabinet.

<sup>1</sup>If an HA32A-Cx cabinet is being installed, a neutral conductor is not required.

### 1.3.2 HA32B UPS Battery Cabinet

The electrician's responsibilities during the installation of the HA32B-xx UPS Battery Cabinet are listed below.

Check Off	Function	Task
<input type="checkbox"/>	Cable Entry/Exit	Perform the cable knockouts and provide the fittings and conduits for this cabinet. Refer to the <i>HA3000 20-80 kVA Uninterruptible Power System Installation Drawings</i> (EK-HA32X-ID) for cable entry/exit location.
<input type="checkbox"/>	Power and Ground Connections (supplied by the electrician)	Provide three power cables and crimp terminals; positive, negative, and ground. The battery wiring should be sized to keep the total cable voltage drop to less than 0.5 Vdc at the current shown in Table 4-2.
<input type="checkbox"/>	Cable Connections	Connect the cables from the dc output busbars in the UPS Battery Cabinet (Figure 4-4) to the dc input busbars in the UPS cabinet (Figure 4-1). Correct dc polarity must be observed when making these connections.
<input type="checkbox"/>	Control Wire Connections (supplied by the electrician)	Provide two control wires (600 V rated) for the QF1 24 Vdc UV Release, and connect them from TB1-1 and TB1-2 in the UPS Battery Cabinet (Figure 4-4) to TB1-1 and TB1-2 in the UPS cabinet (Figure 4-3).
<input type="checkbox"/>	Control Wire Connections (supplied by the electrician)	Provide two control wires (600 V rated) for the QF1 Auxiliary Contacts, and connect them from TB1-4 and TB1-5 in the UPS Battery Cabinet (Figure 4-4) to TB1-4 and TB1-5 in the UPS cabinet (Figure 4-3).
<input type="checkbox"/>	Option Dependent Control Wire Connections (supplied by the electrician)	Provide two control wires (600 V rated) if the DC Ground Fault Detector is installed in the UPS Battery Cabinet, and connect them from TB1-7 and TB1-8 in the UPS Battery Cabinet (Figure 4-4) to TB1-7 and TB1-8 in the UPS cabinet (Figure 4-3).
<input type="checkbox"/>	Option Dependent Control Wire Connections (supplied by the electrician)	Provide four control wires (600 V rated) if the Smoke Detector is installed in the UPS Battery Cabinet, and connect them from TB1-9, TB1-10, TB1-11, and TB1-12 in the UPS Battery Cabinet (Figure 4-4) to TB1-9, TB1-10, TB1-11, and TB1-12 in the UPS cabinet (Figure 4-3).

### 1.3.3 HA32C/D/E UPS Auxiliary Cabinet

The electrician's responsibilities during the installation of the HA32C/D/E UPS Auxiliary Cabinet are listed below.

Check Off	Function	Task
<input type="checkbox"/>	Cable Entry/Exit	Perform the cable knockouts and provide the fittings and conduits for this cabinet. Right-side cable entry is possible (Figure 4-6). Refer to the <i>HA3000 20-80 kVA Uninterruptible Power System Installation Drawings</i> (EK-HA32X-ID).
<input type="checkbox"/>	Input Conductors (supplied by the electrician)	Provide four power cables; three phase conductors and a ground conductor (all of equal ampacity) if the UPS Auxiliary Cabinet contains an input isolation transformer. Refer to Table 4-4 for current ratings. Refer to the UPS Auxiliary Cabinet installation instructions in Chapter 4 when making the ac input cable connections.  If no neutral <sup>1</sup> is available from the building distribution system (for example, DELTA only service entrance), a UPS Auxiliary Cabinet with an input isolation transformer may be used to derive a neutral for the UPS cabinet.
<input type="checkbox"/>	Output Conductors	Connect the four output cables that are factory installed in the UPS Auxiliary Cabinet, if the UPS Auxiliary Cabinet contains an input isolation transformer, to the main ac input (MAINS1) or bypass ac input (MAINS2) and neutral busbars in the UPS cabinet. Refer to the UPS Auxiliary Cabinet installation instructions in Chapter 4 when making the output cable connections.
<input type="checkbox"/>	Harmonic Filter Connections	Connect the six cables from the UPS Auxiliary Cabinet to the UPS cabinet if the UPS Auxiliary Cabinet contains an input harmonic current filter. Refer to Figure 4-13 and Figure 4-14 when making the connections.
<input type="checkbox"/>	Control Wire Connections	Connect the two factory installed control wires in the UPS Auxiliary Cabinet to TB2-11 and TB2-12 in the UPS cabinet (Figure 4-3).

<sup>1</sup>If an HA32A-Cx cabinet is being installed, a neutral conductor is not required.

### 1.3.4 HA33D/F UPS CSA Cabinet

The electrician's responsibilities during the installation of the HA33D/F UPS CSA Cabinet are listed below.

Check Off	Function	Task
<input type="checkbox"/>	Cable Entry/Exit	Perform the cable knockouts and provide the fittings and conduits for this cabinet. Right-side cable entry is possible (Figure 4-16). Refer to the <i>HA3000 20-80 kVA Uninterruptible Power System Installation Drawings</i> (EK-HA32X-ID).
<input type="checkbox"/>	Input Conductors (supplied by the electrician)	<p>Provide five power cables; three phase conductors, a ground conductor, and neutral (all of equal ampacity) if the UPS CSA Cabinet contains a CSA assembly only. Refer to the UPS CSA Cabinet installation instructions in Chapter 4 when making the ac input cable connections.</p> <p>Provide four power cables; three phase conductors and a ground conductor (all of equal ampacity) if the UPS CSA Cabinet contains an input isolation/step-down transformer and a CSA assembly. Refer to Table B-9 for current ratings. Refer to the UPS CSA Cabinet installation instructions in Chapter 4 when making the ac input cable connections.</p>
<input type="checkbox"/>	Output Conductors	Connect the output cables that are factory installed in the UPS CSA Cabinet to the main ac input (MAINS1) and bypass ac input (MAINS2) busbars in the UPS cabinet. Refer to the UPS CSA Cabinet installation instructions in Chapter 4 when making the output cable connections.
<input type="checkbox"/>	Control Wire Connections	Connect the two factory installed control wires in the UPS CSA Cabinet to TB2-11 and TB2-12 in the UPS cabinet (Figure 4-3).



### 1.3.5 HA32J/K UPS Distribution Cabinet

The electrician's responsibilities during the installation of the HA32J/K UPS Distribution Cabinet are listed below.

Check Off	Function	Task
<input type="checkbox"/>	Cable Entry/Exit	Use the factory installed distribution cable knockout panels located behind the dead-front panels. Input power to this cabinet is routed through the left-side cable feed area (Figure 4-19).
<input type="checkbox"/>	Input Power Cables (without isolation/step-down transformer)	Route the three phase conductors, the neutral conductor, and the ground conductor that are factory attached in cabinets without an isolation/step-down transformer, from the UPS Distribution Cabinet to the three phase, neutral, and ground busbars (Figure 4-1) in the UPS cabinet and attach.  <b>NOTE:</b> If the site has a UPS Auxiliary Cabinet or a UPS CSA Cabinet, the cables will run through cable trays in these cabinets on their way to the UPS cabinet (Figure 4-7).
<input type="checkbox"/>	Input Power Cables (with isolation/step-down transformer)	Route the three phase conductors and the ground conductor that are factory attached in cabinets with an isolation/step-down transformer, from the UPS Distribution Cabinet to the three phase and ground busbars (Figure 4-1) in the UPS cabinet and attach.  <b>NOTE:</b> If the site has a UPS Auxiliary Cabinet or a UPS CSA Cabinet, the cables will run through cable trays in these cabinets on their way to the UPS cabinet (Figure 4-7).
<input type="checkbox"/>	Control Wire Connections (with isolation/step-down transformer)	Connect the two factory installed control wires in the UPS Distribution Cabinet with an isolation/step-down transformer to TB2-11 and TB2-12 in the UPS cabinet (Figure 4-3).
<input type="checkbox"/>	Output Distribution Cables	Use the knockout panels located directly below the panelboards behind the dead-front panel for routing distribution cables.
<input type="checkbox"/>	Distribution Circuit Breakers	Provide any required distribution circuit breakers and cables.  <b>NOTE:</b> Distribution cables may be purchased from Digital or made by the electrician. If the distribution cables are made by the electrician, Digital recommends that the receptacles be of the isolated ground type (see Section 4.6.4).
<input type="checkbox"/>	Panelboard Labeling	Identify on the panelboard labels what each circuit has for receptacles.

### 1.3.6 HA320-A3 Remote Alarm Panel

The electrician's responsibilities during the installation of the HA320-A3 Remote Alarm Panel are listed below.

<b>Check Off</b>	<b>Function</b>	<b>Task</b>
<input type="checkbox"/>	Mounting	Mount the Remote Alarm Panel in the selected location.
<input type="checkbox"/>	Control Wiring Connections (supplied by the electrician)	Provide six control wires, 600 V rated, and connect them from TB3 in the Remote Alarm Panel to TB2 and TB3 in the UPS cabinet (refer to Section 4.2.7.2).
<input type="checkbox"/>	Power Connections (supplied by the electrician)	Provide two power wires and connect them from a 120 Vac source to TB3-14 and TB3-15 in the Remote Alarm Panel.

## 1.4 DIGITAL SERVICES RESPONSIBILITIES

The following sections contain the responsibilities of Digital Services during site preparation, delivery/handling, and initial startup of the HA3000 series UPS.

### 1.4.1 Site Preparation

Digital Services responsibilities during site preparation are listed below.

Check Off	Function	Task
<input type="checkbox"/>	Physical Size and Weight	Aid the customer in obtaining the size and weight information on the HA3000 series cabinets that are to be installed. Refer to the <i>HA3000 20-80 kVA Uninterruptible Power System Installation Drawings</i> (EK-HA32X-ID) or to Chapter 2 in this manual.
<input type="checkbox"/>	Electrical Requirements	Aid the customer in ensuring that the customer's electrician has the documentation and electrical requirements necessary for performing the installation.
<input type="checkbox"/>	Physical Placement	Aid the customer in determining the exact physical placement of the cabinets. The cabinet dimensions and service clearances must be taken into consideration. The following is a list of the <b>minimum</b> service clearances required.  Rear - 60.96 cm (24 in) Front - 121.92 cm (48 in) Side - 60.96 cm (24 in) on each end of the cabinet configuration Top - 91.44 cm (36 in)  <b>NOTE:</b> Local codes may require more clearance.
<input type="checkbox"/>	Configuration Layout	Aid the customer in planning the configuration layout using the following placement order (left to right): UPS Battery Cabinet(s), UPS cabinet, UPS Auxiliary Cabinet, UPS CSA Cabinet, and UPS Distribution Cabinet.
<input type="checkbox"/>	Inside Delivery Route	Aid the customer in ensuring that there is an unobstructed inside delivery path to the final installation position. Aid the customer in ensuring that elevators, ramps, and flooring along this path can handle the equipment weights and dimensions.

### 1.4.2 Delivery/Handling

Digital Services responsibilities during delivery/handling are listed below.

Check Off	Function	Task
<input type="checkbox"/>	Site Delivery Coordination	Assist the customer in assuring proper delivery and placement of the HA3000 series cabinets.
<input type="checkbox"/>	Configuration Assembly	Assist the customer in removing the appropriate side skins and cover plates before the cabinets are in their final position.
<input type="checkbox"/>	Final Assembly	Assist the customer in replacing all exterior skins. Check to be sure that all cabinets are complete.

### 1.4.3 Initial Startup

Digital Services responsibilities during initial startup of the HA3000 series cabinets are listed below.

Check Off	Function	Task
<input type="checkbox"/>	Prestartup Checks	Perform the checks before startup by referring to Chapter 3 in the <i>HA3000 20-80 kVA Uninterruptible Power System Technical Manual (EK-HA32X-TM)</i> .
<input type="checkbox"/>	Option Checks	If the Remote Alarm Panel, the Smoke Detector, or the DC Ground Fault Detector options are installed, verify the wiring connections.
<input type="checkbox"/>	Initial Startup	Perform the initial startup procedure by referring to Chapter 3 in the <i>HA3000 20-80 kVA Uninterruptible Power System Technical Manual (EK-HA32X-TM)</i> .
<input type="checkbox"/>	Initial Startup Tests	Perform the initial startup tests by referring to Chapter 3 in the <i>HA3000 20-80 kVA Uninterruptible Power System Technical Manual (EK-HA32X-TM)</i> .
<input type="checkbox"/>	Option Verification	If the Remote Alarm Panel, the Smoke Detector, or the DC Ground Fault Detector options are installed, verify them for proper operation.
<input type="checkbox"/>	Operator Training	Demonstrate the operating modes and controls for the customer's operator.
<input type="checkbox"/>	Customer Registration	Register the customer and give them the 1-800-525-7104 number to call if a problem occurs.

# 2

## SITE PREPARATION

---

### 2.1 GENERAL

This chapter contains site preparation information for the HA32A UPS cabinet, the HA32B UPS Battery Cabinet, the HA32C/D/E UPS Auxiliary Cabinet, the HA33D/F UPS CSA Cabinet, and the HA32J/K UPS Distribution Cabinet.

### 2.2 STORAGE

If the equipment is to be stored prior to installation, it should be stored in a cool, dry, well-ventilated location that is protected against rain, splashing water, chemical agents, and so forth. The equipment should be covered with a tarpaulin or plastic wrapper to protect it against dirt, paint, or other foreign materials.

The UPS Battery Cabinet should be placed into service within 30 days from the date of shipment, provided that the UPS Battery Cabinet is not stored in a location where it has been exposed to temperature exceeding 25°C (77°F). Storage at higher temperatures will reduce storage life, and may reduce battery life.

#### CAUTION

**Never store batteries in a discharged condition. Always recharge batteries for at least 24 hours before storage.**

### 2.3 HA32A UPS CABINET

The HA3000 series of UPS equipment is intended for use in a computer room environment (controlled temperature and humidity) and should be installed on a raised computer room floor. Wiring for power and control cables can be accommodated through the bottom of the equipment, or through the right side of each enclosure. Right-side wire entry for the UPS cabinet can be accommodated through the right-side panel (Figure 2-1) or by use of the UPS Auxiliary Cabinet or the UPS CSA Cabinet.

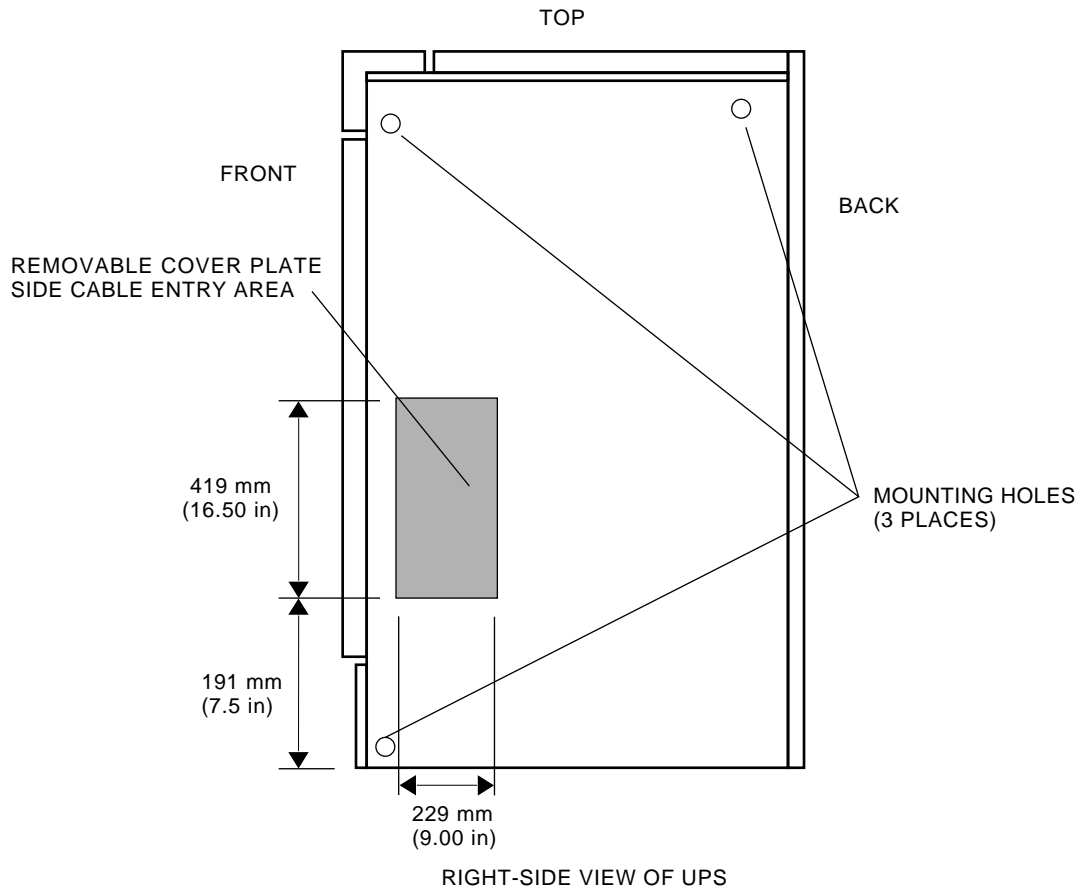

MKV-A2200-91

Figure 2-1 Right-Side Cable Access for the UPS Cabinet

The designated bottom cable entry area for the UPS cabinet is shown in Figure 2-2 for models rated 20 and 40 kVA, and in Figure 2-3 for models rated 60 and 80 kVA.

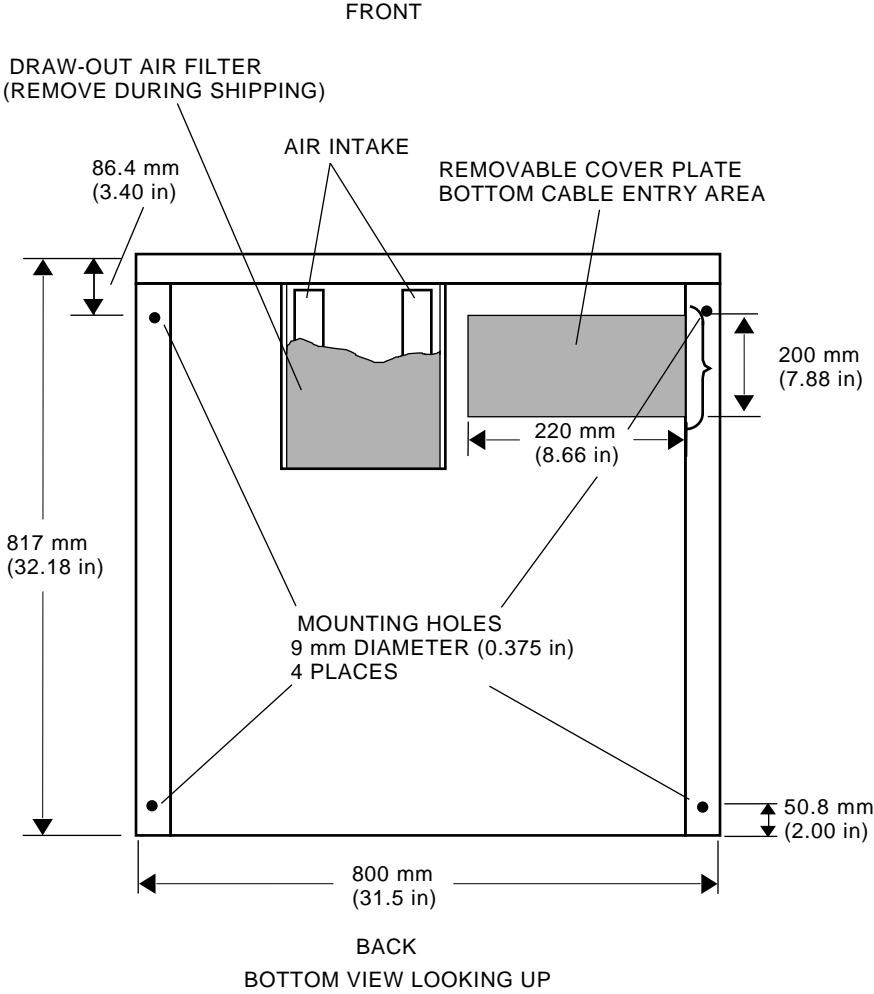

MKV-A2201-91

Figure 2-2 Bottom View, 20 and 40 kVA Models

## 2-4 SITE PREPARATION

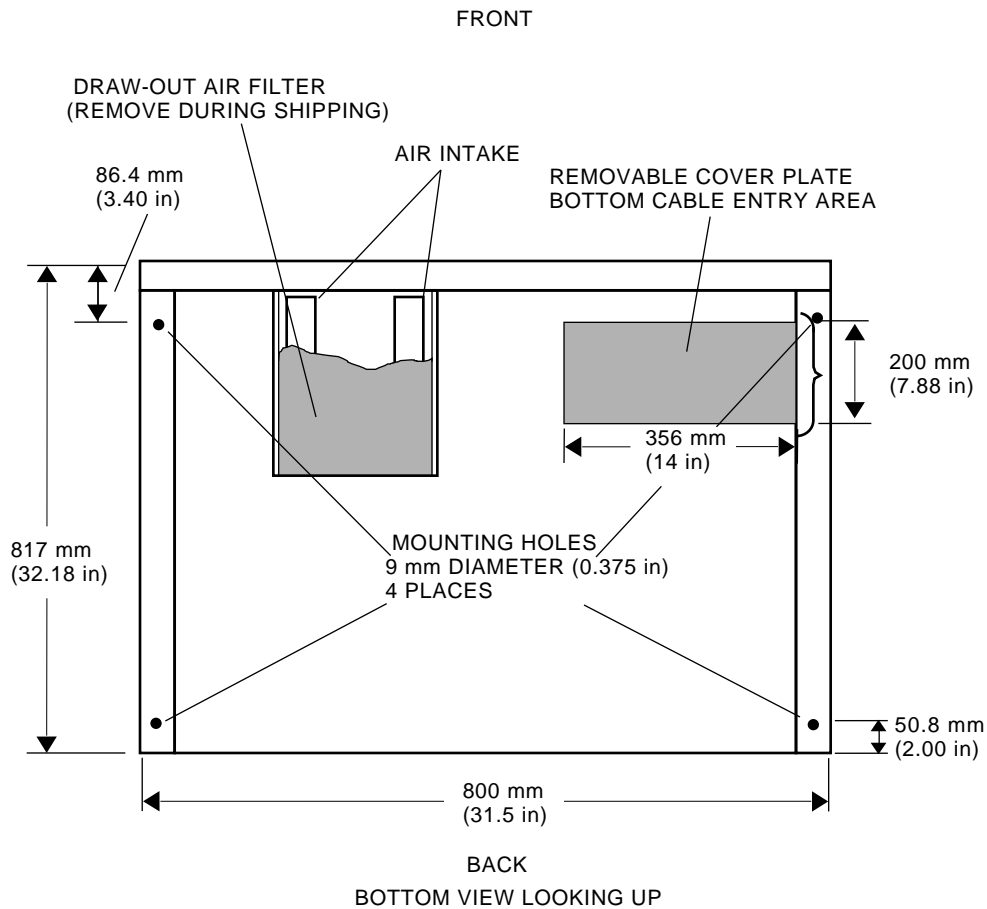

MKV-A2202-91

**Figure 2-3 Bottom View, 60 and 80 kVA Models**

For UPS equipment installed on a raised computer room floor, two floor through-holes should be provided beneath the enclosure. One is for cabling and the other serves as an air inlet for the cooling air required by the UPS. See Figure 2-2 or Figure 2-3 for the location of these holes for your UPS.

### NOTES

**For nonraised floor installations, the area under the draw-out air filter must be kept clear of obstructions for filter installation and servicing.**

The UPS dissipates heat and exhausts warm air through the top portion of the enclosure. Refer to Table 2-1 for heat dissipated (Btu/Hr). Air exhaust for models rated 20 and 40 kVA is 1200 cubic feet per minute (CFM). Air exhaust for models rated 60 and 80 kVA is 1600 CFM.



Table 2-1 also lists the weight and dimensions of the HA32A UPS cabinets.

**Table 2-1 Standard HA32A UPS Models**

<b>Model Number</b>	<b>Output Rating kVA/kW</b>	<b>Nominal Input Voltage 3<math>\Phi</math> (Volts)</b>	<b>Input CB Rating (Amps)</b>	<b>Output Voltage 3<math>\Phi</math> (Volts)</b>	<b>Width mm/in</b>	<b>Approx. Weight kg/lbs</b>	<b>Heat Loss (Full Load) Btu/Hr</b>
HA32A-AH	20/16	208	80	208Y/120	800/31.5	488/1,075	8,189
HA32A-DH	20/16	220	80	220Y/127	800/31.5	488/1,075	8,189
HA32A-BH	20/16	480	40	208Y/120	800/31.5	488/1,075	8,189
HA32A-CH	20/16	480	40	480Y/277	800/31.5	488/1,075	8,189
HA32A-AK	40/32	208	175	208Y/120	800/31.5	628/1,385	15,013
HA32A-DK	40/32	220	175	220Y/127	800/31.5	628/1,385	15,013
HA32A-BK	40/32	480	80	208Y/120	800/31.5	628/1,385	15,013
HA32A-CK	40/32	480	80	480Y/277	800/31.5	628/1,385	15,013
HA32A-AM	60/48	208	250	208Y/120	1,143/45.0	783/1,725	20,130
HA32A-DM	60/48	220	250	220Y/127	1,143/45.0	783/1,725	20,130
HA32A-BM	60/48	480	100	208Y/120	1,143/45.0	783/1,725	20,130
HA32A-CM	60/48	480	100	480Y/277	1,143/45.0	783/1,725	20,130
HA32A-AN	80/64	208	350	208Y/120	1,143/45.0	1,023/2,250	26,954
HA32A-DN	80/64	220	350	220Y/127	1,143/45.0	1,023/2,250	26,954
HA32A-BN	80/64	480	150	208Y/120	1,143/45.0	1,023/2,250	26,954
HA32A-CN	80/64	480	150	480Y/277	1,143/45.0	1,023/2,250	26,954

**Height of all models: 1,402 mm/55.18 in.**  
**Depth of all models: 817 mm/32.18 in.**

The HA32A UPS cabinet is a standalone enclosure. The HA32B UPS Battery Cabinet is a standalone enclosure. The HA32C/D/E UPS Auxiliary Cabinet, when used, attaches to the right side of the HA32A UPS cabinet. The HA33D/F UPS CSA Cabinet, when used, attaches to the right side of the HA32A UPS cabinet or the right side of the HA32C/D/E UPS Auxiliary Cabinet. The HA32J/K UPS Distribution Cabinet, when used, attaches to the right side of the HA32A UPS cabinet, the right side of the HA32C/D/E UPS Auxiliary Cabinet, or the right side of the HA33D/F UPS CSA Cabinet. Refer to the HA32B, HA32C/D/E, HA33D/F, and HA32J/K installation information before performing the HA32A UPS cabinet installation.

## 2.4 HA32B UPS BATTERY CABINET

Before installation of the UPS Battery Cabinet, consideration must be given to the environmental and the structural integrity of its intended location. The electrical wiring must meet both local and national electrical codes.

### 2.4.1 Environmental Considerations

- **Air Temperature:** The **recommended** operating temperature is 25°C (77°F).  
The UPS Battery Cabinet adds an insignificant amount of heat to the environment when fully charged, and normally is not calculated when sizing the capacity of an air conditioner.
- **Air Quality:** The UPS Battery Cabinet should be provided with air free of contaminants such as excessive moisture, vapor, flammable gases, chemical fumes, salt, or excessive dirt and dust.
- **Ventilation:** The UPS Battery Cabinet is designed for operation on a raised computer room floor or a concrete floor. Cooling air for the UPS Battery Cabinet is typically provided through a perforated floor tile on a computer room floor. Cutouts are necessary for bottom access cables only.
- **Humidity:** 10 to 90%, noncondensing.
- **Altitude:** Sea level to 2,134 meters (7,000 feet).

### 2.4.2 Mechanical Considerations

- **Floor Tile Cutout:** A floor tile cutout is required to provide bottom cable entry to the UPS Battery Cabinet. When the UPS Battery Cabinet is installed on a raised computer floor, its weight should be evenly distributed. Locate the corners of the UPS Battery Cabinet as close as possible to the corners of the tiles. Figure 2-4 gives the nominal dimensions and location for this cutout.

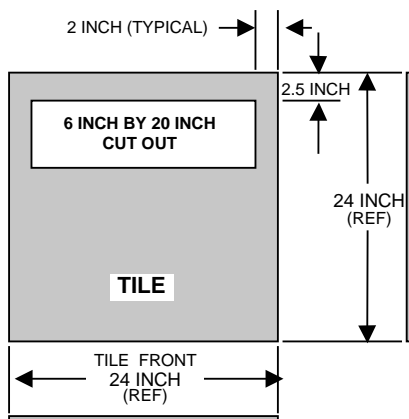

MKV-A2203-91

Figure 2-4 Floor Tile Cutout

- **Floor Loading:** The weight of the UPS Battery Cabinet must be considered when planning the equipment or computer room layout. The floor must be capable of supporting the weight of the UPS Battery Cabinet, as well as all associated equipment (UPS, air conditioning system, furniture, and so forth.) as oriented on your equipment or computer room layout. Particular attention to weight must be given when the equipment is installed on a floor raised above ground level. The approximate weight and dimensions of the UPS Battery Cabinets are listed in Table 2-2.
- **Service Area:** The UPS Battery Cabinet requires rear, top, and front access for servicing. At least 610 mm (24 in.) at the rear of the unit should be allowed for service. At least 914 mm (36 in.) of clearance above the unit should be allowed for normal ventilation. At least 1,219 mm (48 in.) in front of the unit should be allowed for service. This will provide sufficient area to allow the pull-out rack assembly to be removed from the unit.

**Table 2-2 UPS Battery Cabinet Model Numbers**

<b>Model Number</b>	<b>kVA Rating</b>	<b>Nominal Protection in Minutes</b>	<b>Circuit Breaker (QF1) Rating in Amperes</b>	<b>Width of Battery Cabinet (mm/in)</b>	<b>Approx. Installed Weight (kg/lbs)</b>
HA32B-AH	20	5	90	800/31.5	530/1,169
HA32B-CH	20	15	90	800/31.5	530/1,169
HA32B-FH	20	30	90	1,143/45.0	905/1,995
HA32B-AK	40	5	125	800/31.5	530/1,169
HA32B-CK	40	14	125	1,143/45.0	905/1,995
HA32B-FK <sup>1</sup>	40	30	125	2 x 1,143/45.0	2 x 826/1,820
HA32B-AM	60	5	175	1,143/45.0	905/1,995
HA32B-CM <sup>1</sup>	60	10	175	2 x 1,143/45.0	2 x 826/1,820
HA32B-FM <sup>1</sup>	60	30	175	2 x 1,143/45.0	2 x 826/1,820
HA32B-AN	80	5	225	1,143/45.0	905/1,995
HA32B-CN <sup>1</sup>	80	14	225	2 x 1,143/45.0	2 x 826/1,820
HA32B-FN <sup>1</sup>	80	22	225	2 x 1,143/45.0	2 x 905/1,995

<sup>1</sup>Consists of two battery cabinets with same dimensions and weight.

**Height of all models: 1,402 mm/55.18 in.**  
**Depth of all models: 817 mm/32.18 in.**

## 2.5 HA32C/D/E UPS AUXILIARY CABINET

The HA32C/D/E UPS Auxiliary Cabinet is designed to attach to the right side of the HA32A UPS cabinet (Figure 2-5). The weight and dimensions of the UPS Auxiliary Cabinets are listed in Table 2-3.

### NOTE

**The side panels are not provided with the UPS Auxiliary Cabinet. The right side panel of the UPS cabinet must be removed and attached to the right side of the UPS Auxiliary Cabinet after installation.**

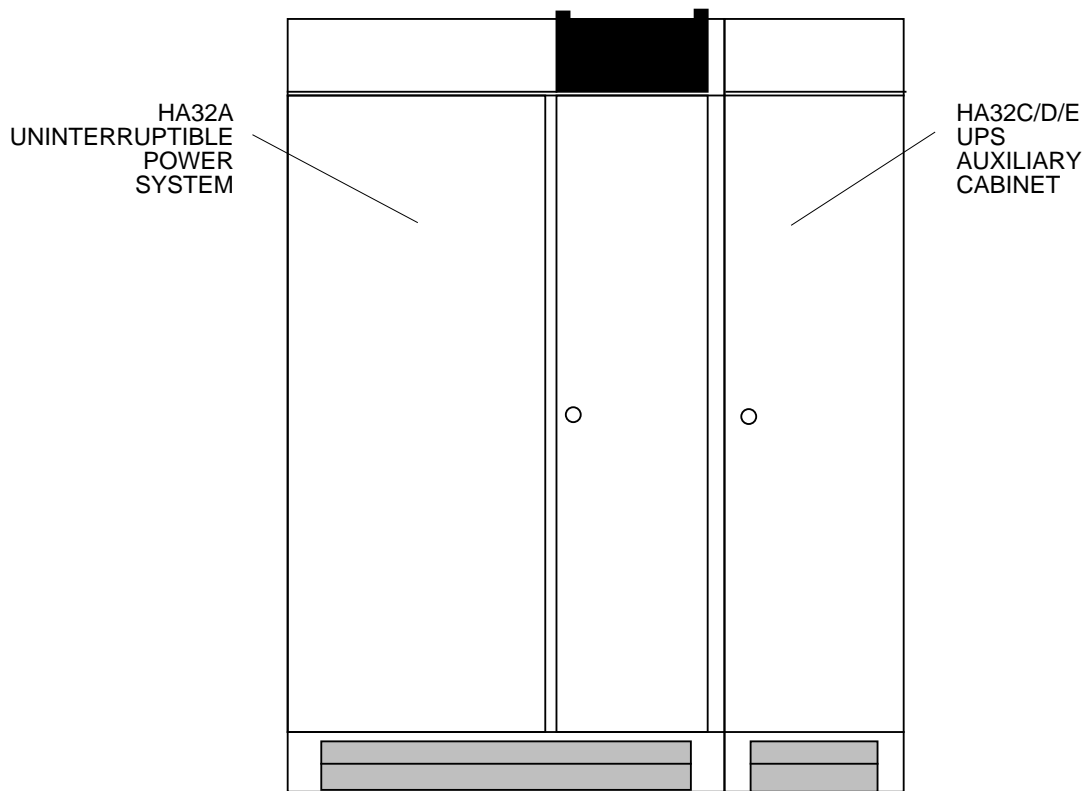

MKV - A 2 2 0 4 - 9 1

**Figure 2-5 UPS Auxiliary Cabinet Placement**

**Table 2-3 UPS Auxiliary Cabinet Weights and Dimensions**

<b>Output Rating (kVA)</b>	<b>HA32D-XX Isolation Transformer Only (kg/lbs)</b>	<b>HA32E-PX Input Current Filter Only (kg/lbs)</b>	<b>HA32C-XX Isolation Transformer and Input Current Filter (kg/lbs)</b>
20	204/450	154/341	268/591
40	249/550	169/374	328/724
60	327/720	214/473	450/993
80	386/850	260/573	556/1,255

**Height of all models: 1,402 mm/55.18 in.**  
**Width of all models: 477 mm/18.78 in.**  
**Depth of all models: 817 mm/32.18 in.**

## 2.6 HA33D/F UPS CSA CABINET

The HA33D/F UPS CSA Cabinet is designed to attach to the right side of the HA32A UPS cabinet (Figure 2-6). The weight and dimensions of the UPS CSA Cabinets are listed in Table 2-4.

### NOTE

**The side panels are not provided with the UPS CSA Cabinet. The right side panel of the UPS cabinet must be removed and attached to the right side of the UPS CSA Cabinet after installation.**

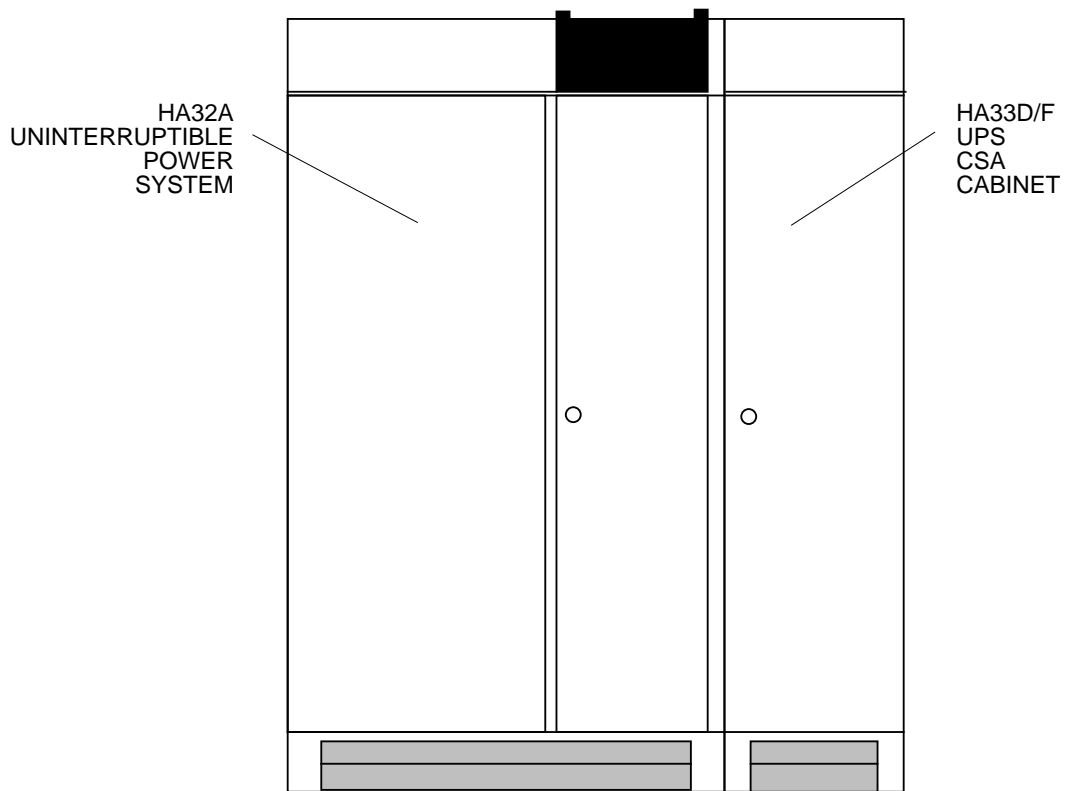

MKV-A2238-91

Figure 2-6 UPS CSA Cabinet Placement

**Table 2-4 UPS CSA Cabinet Weights and Dimensions**

<b>Output Rating (kVA)</b>	<b>HA33D-XX Isolation/Step-Down Transformer and CSA Assembly (kg/lbs)</b>	<b>HA33F-XX CSA Assembly Only (kg/lbs)</b>
20	211/465	98/215
40	256/565	98/215
60	333/735	98/215
80	392/865	98/215

**Height of all models: 1,402 mm/55.18 in.**  
**Width of all models: 477 mm/18.78 in.**  
**Depth of all models: 817 mm/32.18 in.**

## 2.7 HA32J/K UPS DISTRIBUTION CABINET

The UPS Distribution Cabinet is designed to attach to the right side of the HA32A UPS cabinet (Figure 2-7), or to the right side of the UPS Auxiliary Cabinet or UPS CSA Cabinet (Figure 2-8), if one or both of these options have been purchased. Table 2-5 contains the specifications for the UPS Distribution Cabinets.

### NOTES

**The side panels are not provided with the UPS Distribution Cabinet. The right side panel from the HA32A UPS cabinet, the UPS Auxiliary Cabinet, or the UPS CSA Cabinet must be removed and attached to the right side of the UPS Distribution Cabinet after installation.**

**The UPS Distribution Cabinet cannot be installed as a free-standing unit. If a free-standing distribution unit is required, a unit designed for this purpose, such as a 4N-CMCCx-xx Power Distribution Unit (PDU), can be used.**

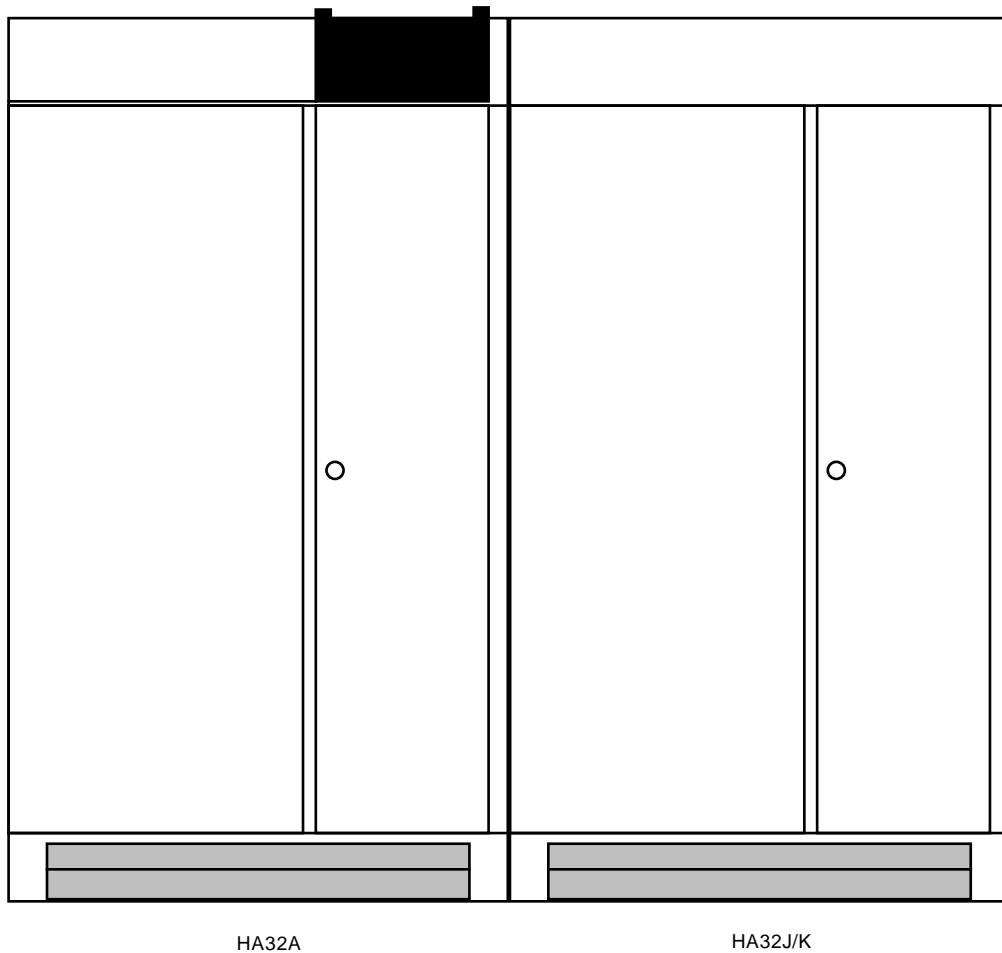

MKV-A2205-91

**Figure 2-7 UPS Cabinet and UPS Distribution Cabinet Placement**



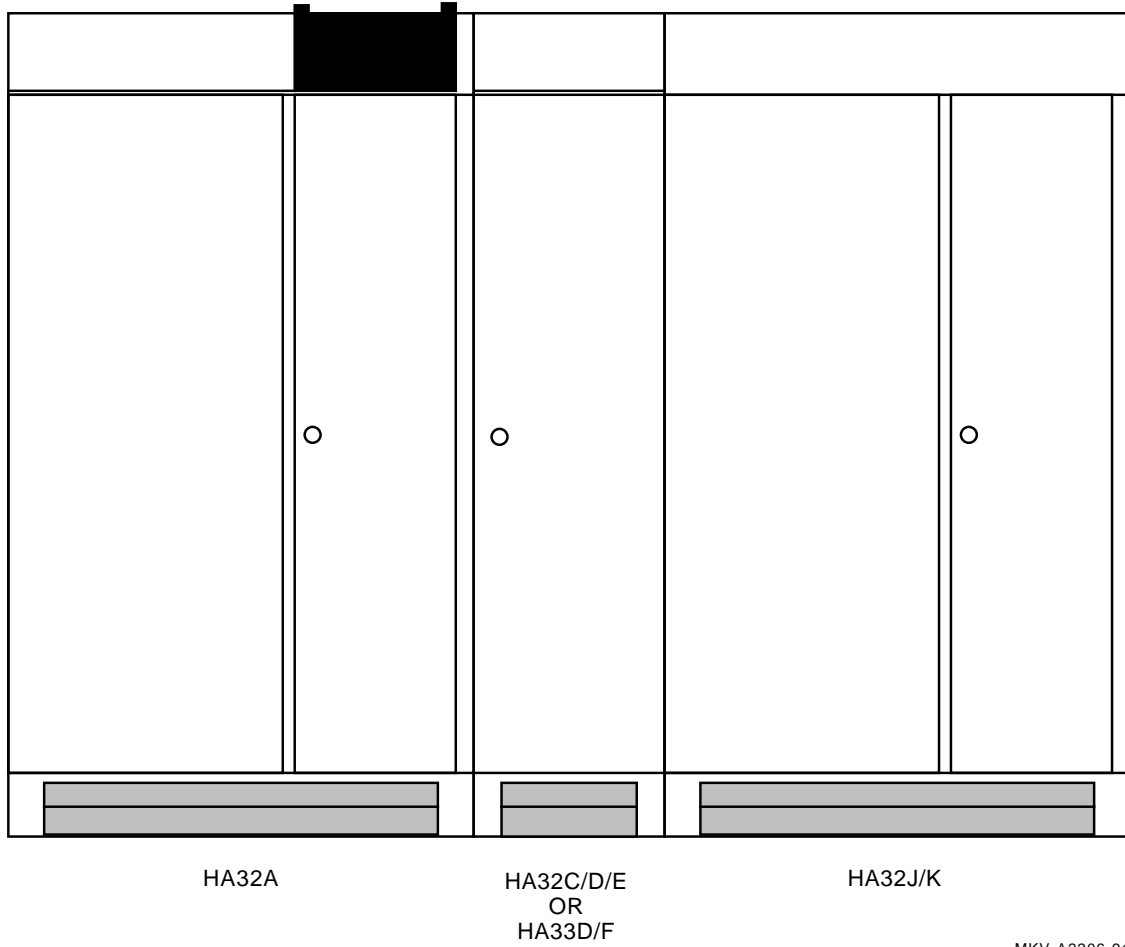

**Figure 2-8 UPS Cabinet, UPS Auxiliary Cabinet or UPS CSA Cabinet, and UPS Distribution Cabinet Placement**

**Table 2-5 UPS Distribution Cabinet Specifications**

<b>Model Number</b>	<b>UPS Output Rating (kVA)</b>	<b>Input Voltage (Vac)</b>	<b>Maximum Input Current (Amps)</b>	<b>Output Voltage (Vac)</b>	<b>Maximum Output Current (Amps)</b>	<b>Weight (kg/lbs)</b>
HA32J-AT <sup>1</sup>	20 - 40	208/220	222	208/220	222	225/495
HA32K-AT <sup>1</sup>	60 - 80	208/220	222	208/220	222	239/525
HA32J-AH	20	208	55.5	208	55.5	352/775
HA32J-BH	20	480	24.1	208	55.5	352/775
HA32J-DH	20	220	55.5	220	55.5	352/775
HA32J-AK	40	208	111	208	111	389/855
HA32J-BK	40	480	48.1	208	111	389/855
HA32J-DK	40	220	111	220	111	389/855
HA32K-AK	40	208	111	208	111	399/880
HA32K-BK	40	480	48.1	208	111	399/880
HA32K-AM	60	208	166.5	208	166.5	461/1,015
HA32K-BM	60	480	72.2	208	166.5	461/1,015
HA32K-DM	60	220	166.5	220	166.5	461/1,015
HA32K-AN	80	208	222	208	222	516/1,135
HA32K-BN	80	480	96.2	208	222	516/1,135
HA32K-DN	80	220	222	220	222	516/1,135

<sup>1</sup>These models DO NOT contain an isolation/step-down transformer. The input voltage will equal the output voltage.

The HA32J-XX models contain one (1) 42-pole panelboard.

The HA32K-XX models contain two (2) 42-pole panelboards.

**Height of all models: 1,402 mm/55.18 in.**  
**Width of all models: 800 mm/31.50 in.**  
**Depth of all models: 817 mm/32.18 in.**

# 3

## HA3000 UPS RECEIVING AND HANDLING

---

### 3.1 GENERAL

This chapter contains the procedures for receiving and handling the HA3000 series equipment cabinets.

The handling of the HA3000 series equipment cabinets is the responsibility of the trucker/mover/rigger, and should be considered part of inside delivery.

The following is a list of the equipment and tools needed for moving and handling the HA3000 series cabinets.

- Pallet mover or forklift
- Rolla-lift (Models M-4, M-4-6, or CD-6)
- 9/16-inch wrench
- Phillips screwdriver
- 5/8-inch wrench
- 1/2-inch wrench
- 3/8-inch wrench

### 3.2 RECEIVING

Inspect the exterior of all shipping containers and the equipment for damage that may have occurred during transit. If the shipping containers or equipment show evidence of damage, note the damage on the receiving document before signing for receipt of equipment.

The equipment should be unpacked immediately after receipt, and inspected again to determine if any internal shipping damage has occurred. Verify that the equipment nameplates correspond with the equipment ordered.

Damage claims should be filed directly with the carrier. Replacements for damaged components should be ordered through the local Digital Services account representative.

### 3.3 HANDLING

The HA3000 series of UPS equipment is designed for handling primarily from the bottom (Figure 3-1). For HA3000 series UPS cabinet dimensions and weights, refer to Chapter 2. The individual cabinets are mounted on a shipping pallet and covered by a cardboard shipping carton. They are designed to be moved by a pallet mover, a rolla-lift (Models M-4, M-4-6, or CD-6), or a forklift-type truck. The front and rear lower cover plates of each cabinet are removed for shipment. The HA32A UPS cabinet has a draw-out input air filter located under the enclosure, which is also removed for handling or transit. The UPS draw-out input air filter can be pulled out from beneath the enclosure once the front lower cover plate is removed.

The HA3000 series equipment cabinets can be handled or moved by overhead equipment after they have been fitted with the necessary slings and spreaders (Figure 3-1).

Use the following procedures to move the HA32A UPS cabinet, the HA32B UPS Battery Cabinet, the HA32C/D/E UPS Auxiliary Cabinet, the HA33D/F UPS CSA Cabinet, or the HA32J/K UPS Distribution Cabinet from the shipping truck to the final installation position. This procedure is a general guideline, and all safety precautions should be followed.

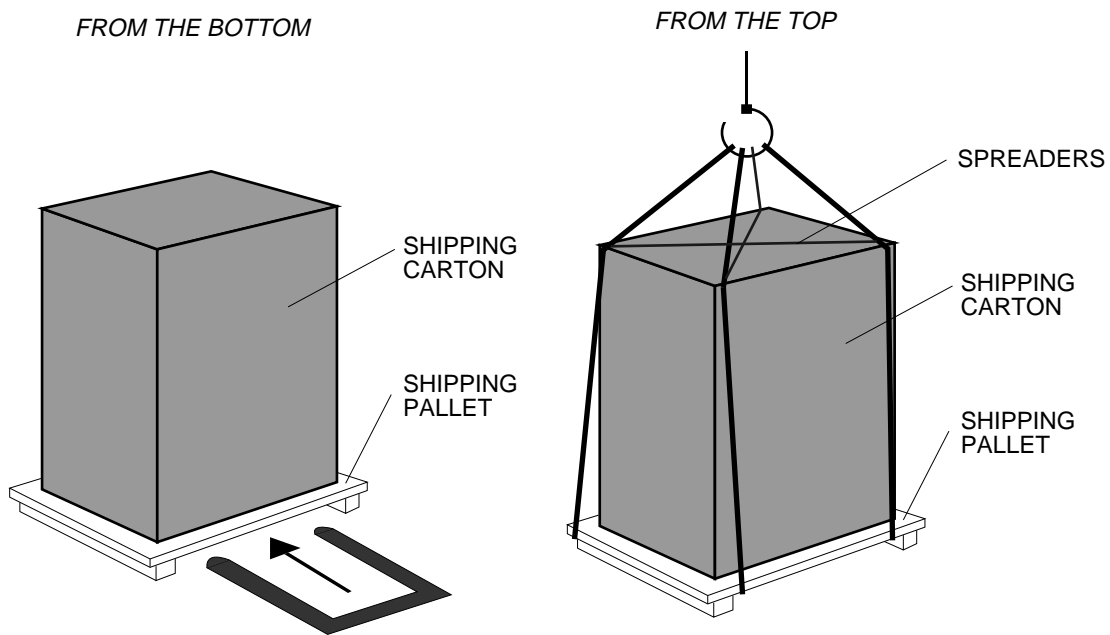

**Figure 3-1 Handling the HA3000 Series Cabinets**

### 3.3.1 Removing Unit from Truck

Use a pallet mover or a forklift to move the HA3000 series UPS shipping pallet from the shipping truck to the loading dock.

### 3.3.2 Removing Shipping Carton

1. Cut the two plastic bands that secure the shipping carton to the pallet.
2. Following the directions on the shipping carton, cut two adjacent vertical edges of the shipping carton, raise the panel between the vertical cuts, and push the shipping carton off of the HA3000 series cabinet.
3. Slide the plastic shipping bag off the cabinet.
4. Open the fastened door on the cabinet with the supplied key, and verify that the equipment nameplate on the inside of the door corresponds to the equipment required for the specific site.
5. Close the door and replace the plastic shipping bag on the cabinet.

#### NOTE

**Carefully inspect the packing materials for additional hardware before discarding.**

### 3.3.3 Removing Unit from Pallet

1. Remove the two corner boards from each vertical edge of the HA3000 series cabinet.
2. Remove the four mounting brackets that secure the HA3000 series cabinet to the shipping pallet.
  - a. Use a 9/16-inch wrench to remove the bolts that secure the mounting brackets to the pallet.
  - b. Use a Phillips screwdriver to remove the screws that secure the mounting brackets to the HA3000 series cabinet.
3. Use a rolla-lift pair to remove the HA3000 series cabinet from the shipping pallet. This requires at least two people.
  - a. Place four corner boards across the top of each rolla-lift half to prevent damaging the front and rear panels.
  - b. Place one half of the rolla-lift on the front side and the other half of the rolla-lift on the rear side of the HA3000 series cabinet.
  - c. Gradually tighten the strapping between the rolla-lift halves until they are resting securely against the HA3000 series cabinet.
  - d. Raise both rolla-lift halves simultaneously until the four casters are above the top surface of the pallet.
  - e. Pull the pallet out from under the HA3000 series cabinet, or roll the HA3000 series cabinet to the side, until it is clear of the pallet.

### 3.3.4 Recommended Layout

The UPS Battery Cabinet should always be placed to the left of the UPS cabinet. The UPS Auxiliary Cabinet is always bolted to the right side of the UPS cabinet. The UPS CSA Cabinet is bolted to the right side of the UPS cabinet or to the right side of the UPS Auxiliary Cabinet if a UPS Auxiliary Cabinet is installed. The UPS Distribution Cabinet is bolted to the right side of the UPS Auxiliary Cabinet or to the right side of the UPS CSA Cabinet if a UPS CSA Cabinet is installed. If a UPS Auxiliary Cabinet or a UPS CSA Cabinet is not used, the UPS Distribution Cabinet is bolted to the right side of the UPS cabinet. Figure 3-2 shows a typical HA3000 series UPS layout.

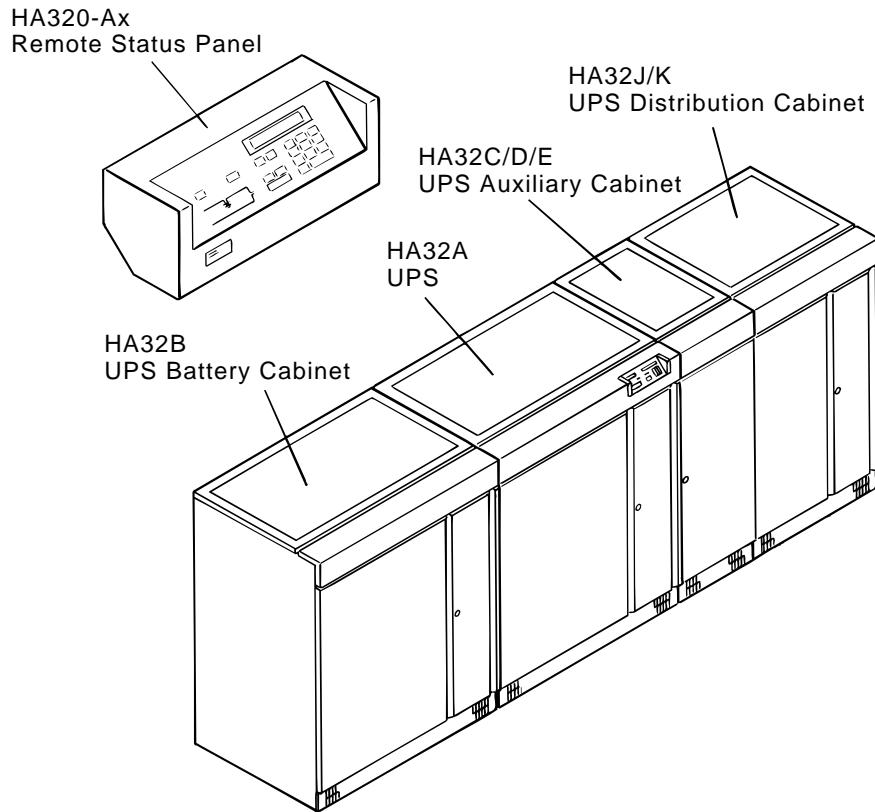

MKV-A2078-91

Figure 3-2 HA3000 Series UPS Layout

### 3.3.5 Moving Unit to Final Position

Digital recommends that the HA3000 series cabinets be left on the rolla-lifts for moving them to the final position.

If the trucker/mover/rigger desires, the following procedure can be used to move the HA3000 series cabinet to the final position on the cabinet casters.

1. Ensure that the four caster lifting legs are raised enough to allow the HA3000 series cabinet to rest on the four casters.
2. Slowly lower both rolla-lift halves simultaneously until the HA3000 series cabinet is resting on the four casters.
3. Use a sufficient number of people to roll the HA3000 series cabinet to the installation area.
4. Slide the plastic shipping bag off the HA3000 series cabinet.
5. Roll the HA3000 series cabinet to the final installation position.

### 3.3.6 Caster Removal

#### NOTE

**All yellow caster assemblies must be removed by the trucker/mover/rigger after final positioning. The caster assemblies are to assist only in moving the unit from the shipping/loading area to the computer room. Proper electrical installation cannot be accomplished unless the yellow caster assemblies have been removed.**

Digital recommends that the HA3000 series cabinets be left on the rolla-lifts for removing the casters.

If the trucker/mover/rigger desires, the following alternate procedure can be used to remove the casters from the HA3000 series cabinet.

1. The trucker/mover/rigger should use a 5/8-inch wrench to lower the four caster lifting legs until they touch the floor.
2. Alternately lower each caster lifting leg one turn at a time until the four casters are off the floor.
3. Use a 1/2-inch wrench to remove the two nuts that secure each of the four casters to the caster rails.
4. Alternately raise each caster lifting leg one turn at a time until the HA3000 series cabinet rests on the bottom rails.
5. Use a 3/8-inch wrench to remove the two bolts that secure each of the two caster rails to the bottom of the unit.
6. Slide the two caster rails out from under the unit.

#### NOTE

**The customer should keep the caster rails, casters, and all mounting hardware at the site to be available for future equipment movement (if needed).**

#### NOTES

**After setting the UPS cabinet in place, remove the rear cover panel. Remove the shipping brace that secures the input transformer (T1) to the right side of the enclosure. The transformer (T1) is on the left side of the enclosure as you look into the unit from the rear. Replace the rear panel. After the equipment is set in place, install the lower rear cover panel, the draw-out air filter, and the lower front cover panel.**

**To install the draw-out air filter brackets, disconnect and remove the left fan. Insert the rear edge of the left bracket in the proper slot underneath the unit. Attach the front end of the left bracket to the bottom of the unit with a bolt through the hole near the left side wall. Insert the rear edge of the right bracket in the proper slot underneath the unit. Attach the front end of the right bracket to the bottom of the unit with a bolt through the hole near the left side wall of the cable entry area. Reinstall and reconnect the left fan. Install the draw-out air filter.**



# 4

## INSTALLATION

---

### 4.1 GENERAL

This chapter contains the installation procedures for the HA32A UPS cabinet, the HA32B UPS Battery Cabinet, the HA32C/D/E UPS Auxiliary Cabinet, the HA33D/F UPS CSA Cabinet, the HA32J/K UPS Distribution Cabinet, the HA320-AA/AB Remote Status Panel, the HA320-A3 Remote Alarm Panel, the HA320-C2 DC Ground Fault Detector, and the HA320-B1 Smoke Detector.

### 4.2 HA32A UPS Cabinet

Before making any electrical connections, check that all ac input feeder circuit breakers or fused switches that will interface with the UPS cabinet are in the off position. In addition, make certain that the UPS cabinet ac input (MAINS1) circuit breaker Q1, the bypass ac input (MAINS2) switch Q4S, the manual bypass switch Q3BP, and the UPS cabinet output isolation switch Q5N are in the off position. Also, make sure that the circuit breaker QF1 on the UPS Battery Cabinet is in the off position.

All field wiring connections for the UPS cabinet are made in the lower-right portion of the UPS enclosure (Figure 4-1). To gain access to this area, the right front door of the UPS cabinet must be unlocked and opened, and the inside cover panel removed. Cables may enter either through the bottom of the UPS cabinet (Figure 2-2 or Figure 2-3), or through the side of the UPS cabinet (Figure 2-1), whichever is the most convenient for your installation.

A minimum 24-inch rear access area for the UPS cabinet is required once the UPS cabinet and its auxiliary equipment have been installed. Local codes may require more rear access area.

#### NOTE

**The HA3000 series UPS may or may not be considered a separately derived system and may be a part of a premise's wiring under the National Electrical Code. All input and output connections must be made in accordance with the National Electrical Code (ANSI/NFPA 70) and with local codes as applicable.**

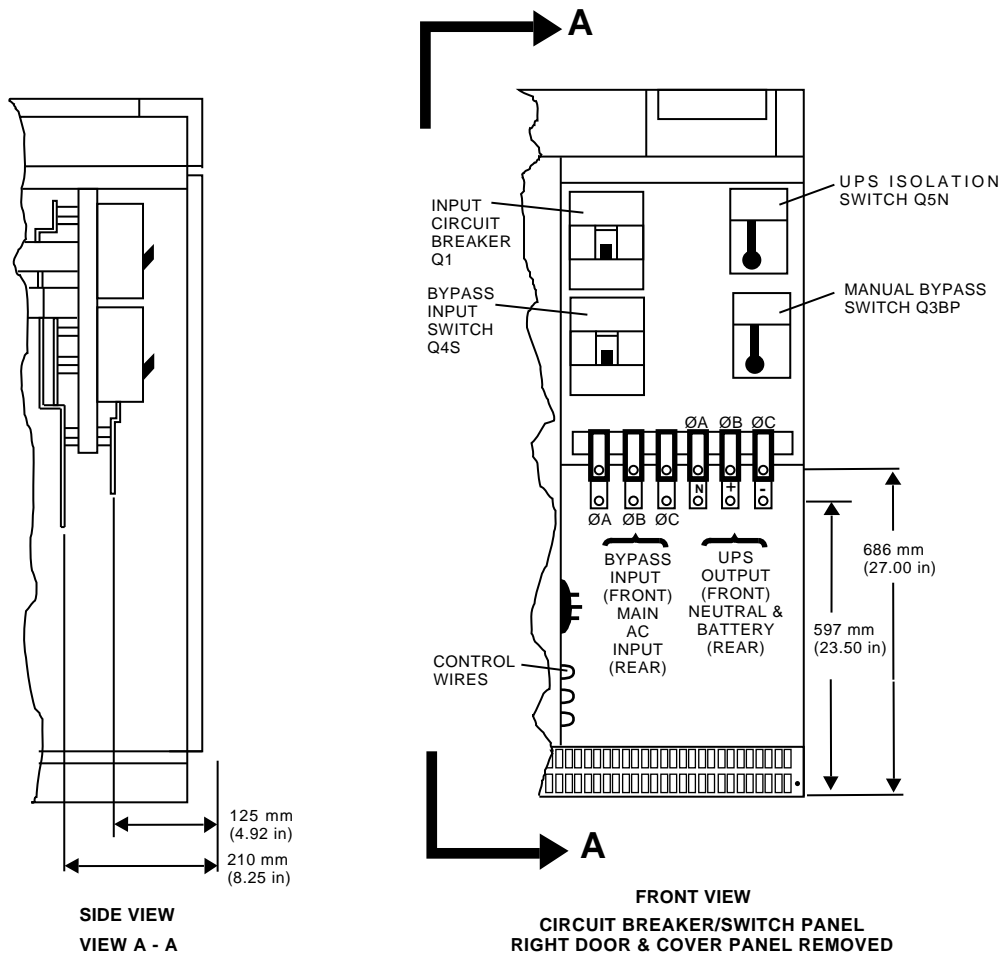

MKV-A2208-91

Figure 4-1 UPS Cabinet Power Wiring Connections

### 4.2.1 Main AC Input (MAINS1) Connection

The main ac input connection is three-phase, three wires plus equipment ground. The phase rotation must be A, B, C. Refer to Table 2-1 for the input circuit breaker rating for the unit you have ordered. Refer to Table 4-1 for the nominal ac input current at the nominal ac input voltage specified. Size the main ac input cables and upstream protection devices accordingly.

#### NOTES

**For ease of installation, the ac input connections should be made first.**

**If only one ac input source is going to be run to the UPS cabinet, jumpers must be installed from the main ac input connections to the bypass ac input connections. In addition, a four-wire Wye source must be run to the UPS cabinet. The neutral<sup>1</sup> wire must be connected to the neutral terminal in the UPS cabinet.**

<sup>1</sup> The HA32A-Cx cabinet does not require a neutral conductor or a Wye power source.

Table 4-1 HA32A Currents

	HA32A-xH	HA32A-xK	HA32A-xM	HA32A-xN
<b><u>Output Power Rating</u></b>				
<b>kVA/kW</b>	20/16	40/32	60/48	80/64
<b><u>Unit Nominal AC Input Current (Amperes) @ Nominal Input Voltage</u></b>				
<b>208 Vac</b>	61.5	121.5	180.4	237.7
<b>220 Vac</b>	58.2	114.9	170.5	224.8
<b>480 Vac</b>	29.3	52.7	78.2	103.0
<b><u>Unit AC Output and Bypass AC Input Current (Amperes) @ Nominal Voltage (Note 1)</u></b>				
<b><u>Full Load Continuous</u></b>				
<b>208Y/120</b>	55.5	111.0	166.5	222.1
<b>220Y/127</b>	52.5	105.0	157.5	209.9
<b>480Y/277</b>	24.1	48.1	72.2	96.2
<b><u>125% Overload for 10 Minutes</u></b>				
<b>208Y/120</b>	69.4	138.8	208.2	277.6
<b>220Y/127</b>	65.6	131.2	196.8	262.4
<b>480Y/277</b>	30.1	60.1	90.2	120.3
<b><u>150% Overload for 1 Minute</u></b>				
<b>208Y/120</b>	83.3	166.5	249.8	333.1
<b>220Y/127</b>	78.7	157.5	236.2	314.9
<b>480Y/277</b>	36.1	72.2	108.3	144.3
<b><u>Maximum Battery Current (Note 2)</u></b>				
<b>Amperes</b>	54.6	109.2	163.9	218.5

**NOTES:**

1. As a minimum, bypass ac input (MAINS2) power should match the UPS output rating. The bypass ac input should have a continuous rating of 125% of the UPS output power rating, however, to supply fault-clearing current.
2. Battery wiring should be sized to keep the total cable voltage drop to less than 0.5 Vdc at the current shown.

### 4.2.2 Bypass AC Input (MAINS2) Connection

The bypass ac input connection is three-phase, four-wire Wye<sup>1</sup> plus equipment ground. The phase rotation must be A, B, C. Bypass ac input (MAINS2) voltage must match the UPS output voltage. Refer to Table 4-1 for the nominal bypass ac input current at the nominal bypass ac input voltage specified. Size the bypass ac input cables and upstream protection devices accordingly.

#### CAUTION

**Single-point grounding: The UPS cabinet is shipped from the factory with the neutral bus tied to ground with a jumper that has a yellow tag attached (Figure 4-2). If the UPS cabinet bypass ac input (MAINS2) source already has the neutral grounded (either from the facility power source or from the UPS Auxiliary Cabinet/CSA Cabinet isolation transformer), remove the jumper between the neutral and ground busbars in the UPS cabinet. This prevents a ground loop problem.**

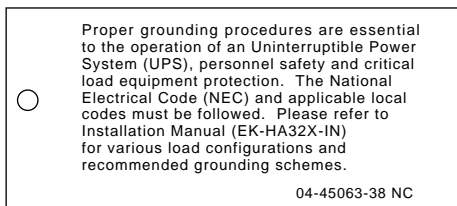

MKV-A2243-91

Figure 4-2 Yellow Jumper Tag

### 4.2.3 UPS Output Load Connection

The UPS output load connection is three-phase, four-wire Wye plus equipment ground. Phase rotation is A, B, C. Refer to Table 4-1 for the unit ac output current rating at the nominal output voltage specified. Size the output cables and downstream protective devices accordingly.

#### NOTE

**A three-wire Delta load can be connected to the UPS inverter output. This Delta load cannot have any grounded phase connections.**

### 4.2.4 Battery Connection

For each individual UPS Battery Cabinet three wires are required: positive (+), negative (-), and ground from the UPS Battery Cabinet to the UPS cabinet. Refer to Table 4-1 for the maximum battery current required for the unit specified. Battery cables should be sized to keep the total cable voltage drop to less than 0.5 Vdc at the maximum current specified.

<sup>1</sup> The HA32A-Cx cabinet does not require a neutral conductor or a Wye power source. Three phase wires plus equipment ground are required for these models.

### 4.2.5 UPS Battery Cabinet Control Wire Connections (TB1)

Refer to Figure 4-1 for the location of the control wiring interface in the UPS cabinet, and to Figure 4-3 for detailed connection information.

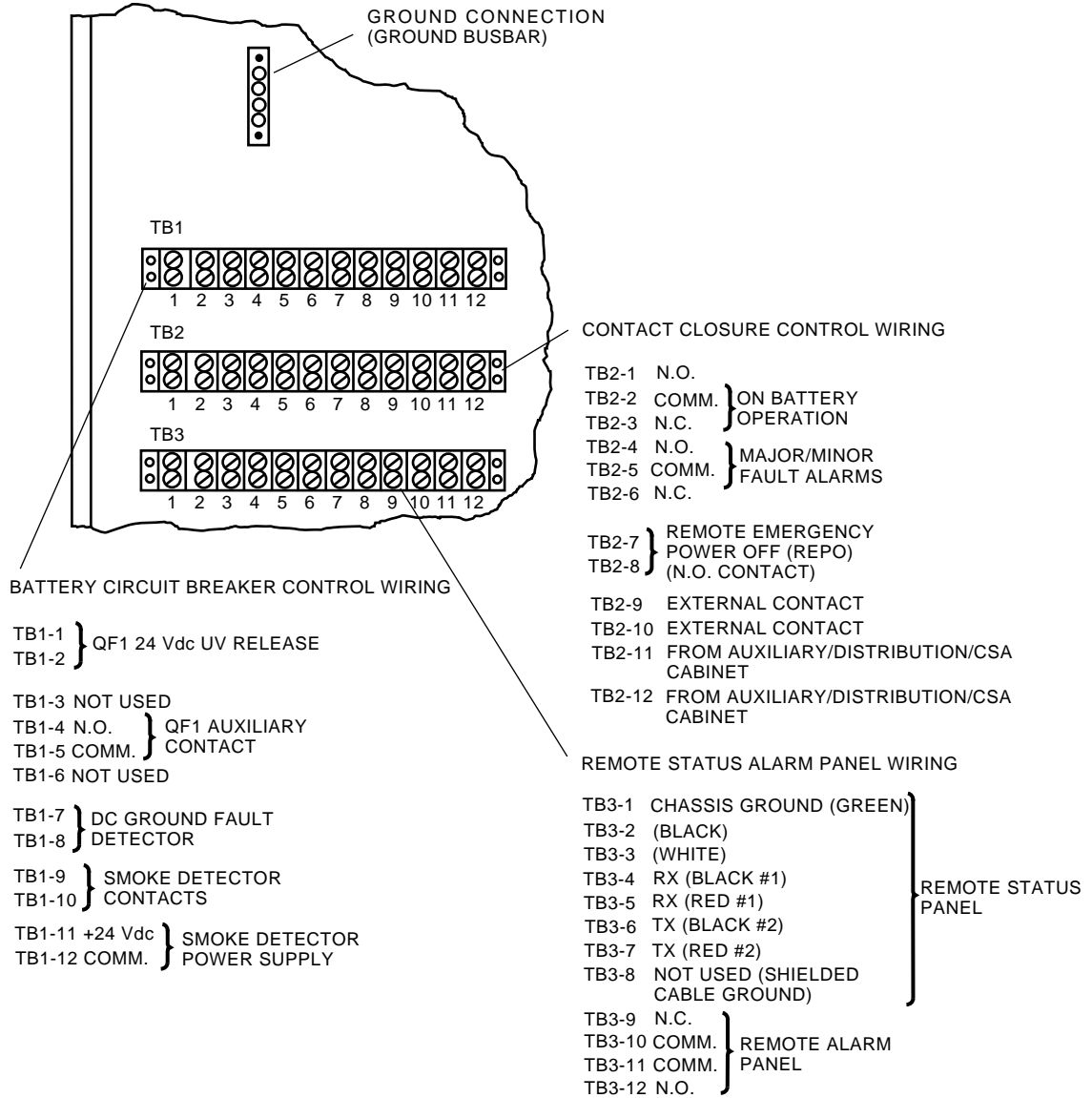

MKV-A2209-91

Figure 4-3 UPS Cabinet Control Wiring Connections

#### **4.2.5.1 Battery Cabinet Circuit Breaker (QF1) Control Wiring**

The UPS Battery Cabinet circuit breaker requires four (4) wires (TB1-3 and TB1-6 are not used).

Use the following procedure to connect the Battery Cabinet circuit breaker control wires to the UPS cabinet control wiring interface.

1. Connect a control wire from TB1-1 in the UPS Battery Cabinet to TB1-1 in the UPS cabinet.
2. Connect a control wire from TB1-2 in the UPS Battery Cabinet to TB1-2 in the UPS cabinet.
3. Connect a control wire from TB1-4 in the UPS Battery Cabinet to TB1-4 in the UPS cabinet.
4. Connect a control wire from TB1-5 in the UPS Battery Cabinet to TB1-5 in the UPS cabinet.

#### **4.2.5.2 DC Ground Fault Detector Control Wiring**

The DC Ground Fault Detector requires two (2) control wires if it is or will be installed in the UPS Battery Cabinet.

Use the following procedure to connect the DC Ground Fault Detector control wires between the UPS Battery Cabinet and the UPS cabinet control wiring interface.

1. Connect a control wire from TB1-7 in the UPS Battery Cabinet to TB1-7 in the UPS cabinet.
2. Connect a control wire from TB1-8 in the UPS Battery Cabinet to TB1-8 in the UPS cabinet.

#### **4.2.5.3 Smoke Detector Control Wiring**

The Smoke Detector requires four (4) control wires if it is or will be installed in the UPS Battery Cabinet.

Use the following procedure to connect the Smoke Detector control wires between the UPS Battery Cabinet and the UPS cabinet control wiring interface.

1. Connect a control wire from TB1-9 in the UPS Battery Cabinet to TB1-9 in the UPS cabinet.
2. Connect a control wire from TB1-10 in the UPS Battery Cabinet to TB1-10 in the UPS cabinet.
3. Connect a control wire from TB1-11 in the UPS Battery Cabinet to TB1-11 in the UPS cabinet.
4. Connect a control wire from TB1-12 in the UPS Battery Cabinet to TB1-12 in the UPS cabinet.

## 4.2.6 Contact Closure Control Wire Connections (TB2)

Refer to Figure 4-1 for the location of the control wiring interface in the UPS cabinet, and to Figure 4-3 for detailed connection information.

Form "C" dry contacts (rated at 1 A, 24 Vdc, or 120 Vac) are provided. These may be used to remotely annunciate the conditions (1 and 2) below, used to interface with the REPO option signal (3) below, used to interface with customer installed external contacts (4) below, or detect faults in the UPS Auxiliary Cabinet (5) if it is installed:

1. UPS on battery operation
2. Major/minor fault alarm has occurred in the UPS cabinet
3. Remote emergency power off (REPO) connection requires two wires
4. External contacts connection requires two wires provided by the customer
5. UPS Auxiliary Cabinet fault connection requires two wires provided with the Auxiliary Cabinet

## 4.2.7 Remote Status Panel and Remote Alarm Panel Control Wire Connections (TB3)

Refer to Figure 4-1 for the location of the control wiring interface in the UPS cabinet, and to Figure 4-3 for detailed connection information.

This interface is provided for the Remote Status Panel (HA320-AA/AB) option and the Remote Alarm Panel (HA320-A3) option.

### 4.2.7.1 Remote Status Panel Control and Power Wire Connections

A 7-conductor shielded cable assembly is provided with the Remote Status Panel and must be connected to TB3 in the UPS cabinet.

Use the following procedure to connect the power and control wires from the Remote Status Panel to TB3 in the UPS cabinet.

1. From the shielded cable jacket containing three 16 AWG wires, connect the green wire to TB3-1 in the UPS cabinet.
2. From the shielded cable jacket containing three 16 AWG wires, connect the white wire to TB3-3 in the UPS cabinet.
3. From the shielded cable jacket containing three 16 AWG wires, connect the black wire to TB3-2 in the UPS cabinet.
4. From the shielded cable jacket containing four (two twisted pair) 18 AWG wires, connect the black #1 wire to TB3-4 in the UPS cabinet.
5. From the shielded cable jacket containing four (two twisted pair) 18 AWG wires, connect the red #1 wire to TB3-5 in the UPS cabinet.
6. From the shielded cable jacket containing four (two twisted pair) 18 AWG wires, connect the black #2 wire to TB3-6 in the UPS cabinet.
7. From the shielded cable jacket containing four (two twisted pair) 18 AWG wires, connect the red #2 wire to TB3-7 in the UPS cabinet.

#### **4.2.7.2 Remote Alarm Panel Control and Power Wire Connections**

If the Remote Alarm Panel option is installed, six control wires and two power wires must be provided and installed by the customer's electrician.

Use the following procedure to connect the six control wires from TB3 in the Remote Alarm Panel to TB2 and TB3 in the UPS cabinet, and to connect the two power wires from a 120 Vac source to TB3 in the Remote Alarm Panel.

1. Connect a control wire from TB3-1 in the Remote Alarm Panel to TB3-12 in the UPS cabinet.
2. Connect a control wire from TB3-2 in the Remote Alarm Panel to TB2-1 in the UPS cabinet.
3. Connect a control wire from TB3-3 in the Remote Alarm Panel to TB3-9 in the UPS cabinet.
4. Connect a control wire from TB3-4 in the Remote Alarm Panel to TB2-4 in the UPS cabinet.
5. Connect a control wire from TB3-9 in the Remote Alarm Panel to TB2-2 in the UPS cabinet.
6. Connect a control wire from TB3-11 in the Remote Alarm Panel to TB3-11 in the UPS cabinet.
7. Connect two power wires from a 120 Vac source to TB3-14 and TB3-15 in the Remote Alarm Panel.

#### **4.2.8 Checks After Installation**

After installing the UPS cabinet, make the following checks:

1. Ensure that all power and control wires have been properly connected and securely tightened.
2. Check the trip ratings on the upstream and downstream protective devices, and make certain that they are compatible with the UPS cabinet and the load requirements.
3. Verify that the voltage of the main ac input (MAINS1) source and the bypass ac input (MAINS2) source are those shown on the UPS nameplate located inside the right door of the UPS enclosure.
4. Verify that all four circuit breakers and switches (Q1, Q3BP, Q4S, and Q5N) in the UPS cabinet are in the off position.
5. Verify that the battery circuit breaker (QF1) located in the UPS Battery Cabinet is in the off position.



## 4.3 HA32B UPS BATTERY CABINET

The UPS Battery Cabinet is shipped with the lower front and lower rear panels removed. The hardware needed to install these panels is in place.

### 4.3.1 General Installation

The UPS Battery Cabinet is designed for use with the HA32A UPS equipment only. Generally, the UPS equipment is installed as close as possible to the UPS Battery Cabinet (recommended less than 6.1 m [20 ft]). This is done to minimize the size of the battery power conductors that must be run between the UPS cabinet and the UPS Battery Cabinet. Excessive voltage drop in the battery power conductors causes a decrease in the anticipated protection time. The maximum dc current required to flow between the UPS Battery Cabinet and the UPS cabinet with which it is intended to operate is shown in Table 4-2. The maximum cable voltage drop should be limited to 0.5 Vdc at the maximum dc current.

#### CAUTION

**When multiple UPS Battery Cabinets are installed, the lengths of all dc power cables should be the same. This is to prevent differences in cable voltage drop within the operating UPS system.**

Table 4-2 Maximum DC Current Requirements

UPS Battery Cabinet Model Number	Maximum DC Current (Amperes)
HA32B-XH	54.6
HA32B-XK	109.2
HA32B-XM	163.9
HA32B-XN	218.5

The UPS Battery Cabinet is shipped from the factory with all batteries firmly secured in place. Battery strings within a rack are wired together, except for a single link or interbattery connector (one per battery cabinet) that is removed for shipment. This interbattery link must be installed before attempting to use the UPS Battery Cabinet.

#### WARNING

**When securing the battery connections, it is essential to use tools with an insulating sheath and to wear gloves (provided in the Safety Toolkit). A short circuit between battery terminals or other conductive surfaces could be hazardous.**

### 4.3.2 Single UPS Battery Cabinet/HA32A UPS Installation

The UPS Battery Cabinet chassis should be grounded to the same point as that used for the UPS cabinet ground. Power cables and control cables should be run through conduits (local codes may require separate conduits) that can be attached through the bottom rear portion of the UPS Battery Cabinet.

#### NOTE

**For bottom entry, the shipping supports must be removed and replaced with the cable entry cover plates on the 45-inch UPS Battery Cabinets (see drawing 7 of the *HA3000 20-80 kVA UPS Installation Drawings - EK-HA32X-ID*).**

Power cable and control wire connections are made inside the back top portion of the UPS Battery Cabinet (Figure 4-4). To access the interior of the UPS Battery Cabinet, follow this procedure:

1. Remove the back cover on the UPS Battery Cabinet.
2. Open the UPS Battery Cabinet enclosure doors, right door first. Note the location of QF1, the battery disconnect circuit breaker.
3. Remove the screw at the top right portion of the left door, which holds it in place.
4. Remove the red insulating panel(s) from the front of the battery rack(s).
5. Remove the top front corner piece from the UPS Battery Cabinet by removing the two screws that hold it in place. These screws are located in a channel on the top of the UPS Battery Cabinet.
6. Remove the next portion of the top of the UPS Battery Cabinet by removing the two screws located inside the ventilation openings at each side of the top of the unit.
7. The remaining top portion of the unit can be removed by forcing it off toward the rear of the unit.
8. To gain access to the wiring area, which is located inside the UPS Battery Cabinet at the back top portion of the unit, the pull-out rack assembly must be removed. To do this, first remove the two bolts that secure the pull-out rack assembly to the sides of the unit. They are located at the top left and top right side of the pull-out rack assembly. UPS Battery Cabinets that have two pull-out rack assemblies (45-inches wide) have three bolts securing them in place. One bolt secures the left pull-out rack assembly to the left side of the unit in a similar manner to the single pull-out rack assembly. One bolt secures the right pull-out rack assembly to the right side of the unit in a similar manner to the single pull-out rack assembly. The third bolt secures the two pull-out rack assemblies together at the center of the unit. Once the bolts have been removed, the pull-out rack assemblies can be removed from the unit.

#### CAUTION

**The pull-out rack assemblies are connected to the rear of the UPS Battery Cabinet enclosure by two power cables, a ground cable, and control wiring. Exercise caution when pulling out the pull-out rack assembly to avoid straining these connections.**

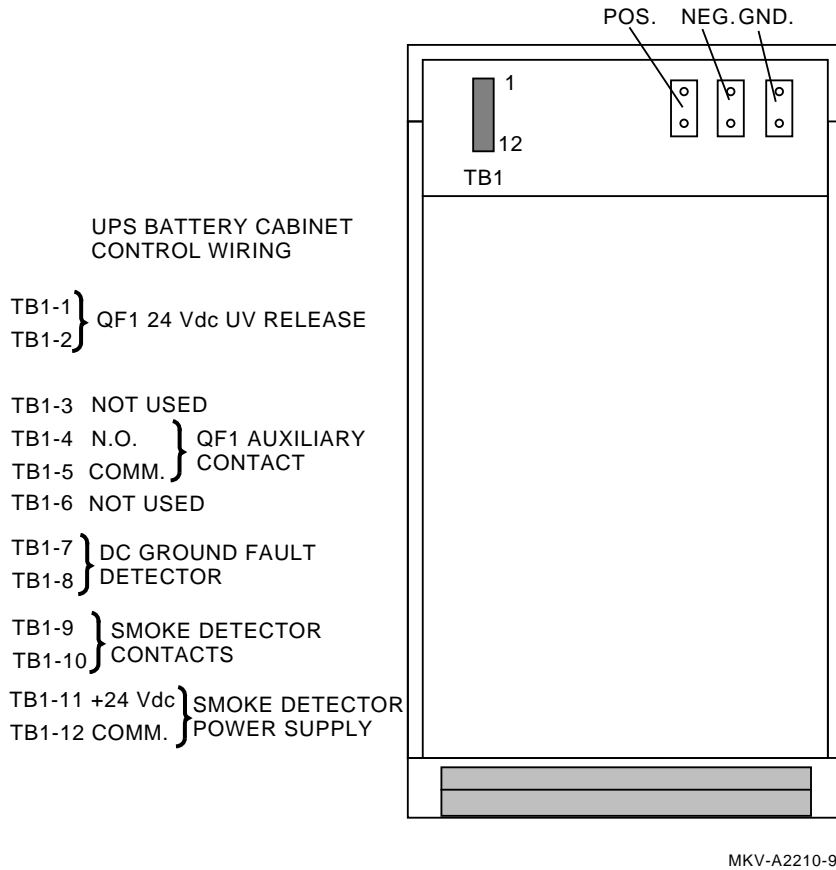

**Figure 4-4 UPS Battery Cabinet Power and Control Wiring Connections**

### 4.3.3 Two UPS Battery Cabinets/HA32A UPS Installation

When two UPS Battery Cabinets are required to meet the specified backup or protection time, each should be installed according to the directions in Section 4.3.2. Except for a common chassis ground connection, no connections should be made between the UPS Battery Cabinets.

### 4.3.4 Power Cable Connections

The power cable connections should be made after selecting the appropriate size wire that satisfies the maximum permissible cable voltage drop requirements specified in Section 4.3.1. Make sure that the correct polarities are observed when making all dc connections. Positive (+) to positive and negative (-) to negative.

Power cable connections and the chassis ground connection are made on the inside rear, top right portion of the UPS Battery Cabinet (Figure 4-4).

See Figure 4-1 for the UPS Battery Cabinet power cable connections in the UPS cabinet. See Figure 4-3 for the chassis ground connection in the UPS cabinet.

### 4.3.5 Control Wire Connections

The control wire connections should be made between the UPS Battery Cabinet and the UPS cabinet as indicated in Figure 4-3 and Figure 4-4. Control wire connections are made inside the rear, top left portion of the UPS Battery Cabinet (Figure 4-4). These wires with terminal connectors attached must be provided by the customer's electrician and should meet all local and national codes. It is recommended that conductors with an insulation value of 600 V or greater be used.

The control wires may need to be run in a separate conduit from the power and ground wiring. Consult local codes for resolution.

### 4.3.6 Interbattery Link Connection

Connect the interbattery link(s) located at the front of the pull-out rack assembly. This link(s) was removed for shipment of the UPS Battery Cabinet to your site. The link is strapped in place adjacent to the batteries to be interconnected. These connections should be torqued to meet the initial torque value requirements in Table 4-3.

**Table 4-3 Interbattery Link Torque Values**

<b>Manufacturer</b>	<b>Model No.</b>	<b>Initial Torque Values</b>	<b>Subsequent Torque Values</b>
Yuasa	DM33-12	1.8 N·m (16.3 inch-pounds)	1.2 N·m (10.85 inch-pounds)
Yuasa	DM55-12	1.8 N·m (16.3 inch-pounds)	1.2 N·m (10.85 inch-pounds)
Yuasa	DM80-12	1.8 N·m (16.3 inch-pounds)	1.2 N·m (10.85 inch-pounds)
Johnson Controls	UPS12-95	3.9 N·m (35.0 inch-pounds)	3.4 N·m (30.0 inch-pounds)
Johnson Controls	UPS12-135	3.9 N·m (35.0 inch-pounds)	3.4 N·m (30.0 inch-pounds)
Johnson Controls	UPS12-225	3.9 N·m (35.0 inch-pounds)	3.4 N·m (30.0 inch-pounds)
Johnson Controls	JC12250	Not applicable	Not applicable

### 4.3.7 Checks After Installation

After installing the UPS Battery Cabinet, make the following checks:

1. Inspect each battery in the UPS Battery Cabinet for cracks or evidence of electrolyte leakage or seepage. Any battery that has a crack or shows evidence of leakage or seepage should be replaced before bringing the UPS Battery Cabinet online.
2. Ensure that all power and control wires have been properly connected and securely tightened.
3. Ensure that the UPS Battery Cabinet battery disconnect circuit breaker QF1 is in the off position.

### 4.3.8 Reassembling the UPS Battery Cabinet

Perform the following steps:

1. Push the pull-out rack assembly into the UPS Battery Cabinet.
2. Replace the two bolts that secure the pull-out rack assembly to the sides of the unit. They are located at the top left and top right side of the pull-out rack assembly. UPS Battery Cabinets that have two pull-out rack assemblies (45-inches wide) have three bolts securing them in place. One bolt secures the left pull-out rack assembly to the left side of the unit in a similar manner to the single pull-out rack assembly. One bolt secures the right pull-out rack assembly to the right side of the unit in a similar manner to the single pull-out rack assembly. The third bolt secures the two pull-out rack assemblies together at the center of the unit.
3. Replace the back top portion of the unit by forcing it on toward the front of the unit.
4. Replace the next portion of the top of the UPS Battery Cabinet by installing the two screws located inside the ventilation openings at each side of the top of the unit.
5. Replace the top front corner piece on the UPS Battery Cabinet by installing the two screws that hold it in place. These screws are located in a channel on the top of the UPS Battery Cabinet.
6. Replace the red insulating panel(s) on the front of the battery rack(s).
7. Replace the back cover on the UPS Battery Cabinet.
8. Close the left door and install the screw at the top right portion of the left door, which holds it in place.
9. Close the UPS Battery Cabinet right door.

## 4.4 HA32C/D/E UPS AUXILIARY CABINET

The HA32C/D/E UPS Auxiliary Cabinet is designed to attach to the right side of the HA32A UPS cabinet (Figure 2-5).

Place the UPS cabinet in its final position. Remove the right side panel and the cover plate for the side cable entry area.

### NOTE

**The side panels are not provided with the UPS Auxiliary Cabinet. Remove the right side panel from the UPS cabinet and attach it to the right side of the UPS Auxiliary Cabinet after installation.**

Place the HA32C/D/E UPS Auxiliary Cabinet on the right side of the HA32A UPS cabinet. The two cabinets must be attached together; three holes are provided for this purpose. Two holes are accessible from the front, and the third can be reached from the top-rear of the enclosure (Figure 4-5). The bolts are provided with the HA32C/D/E UPS Auxiliary Cabinet.

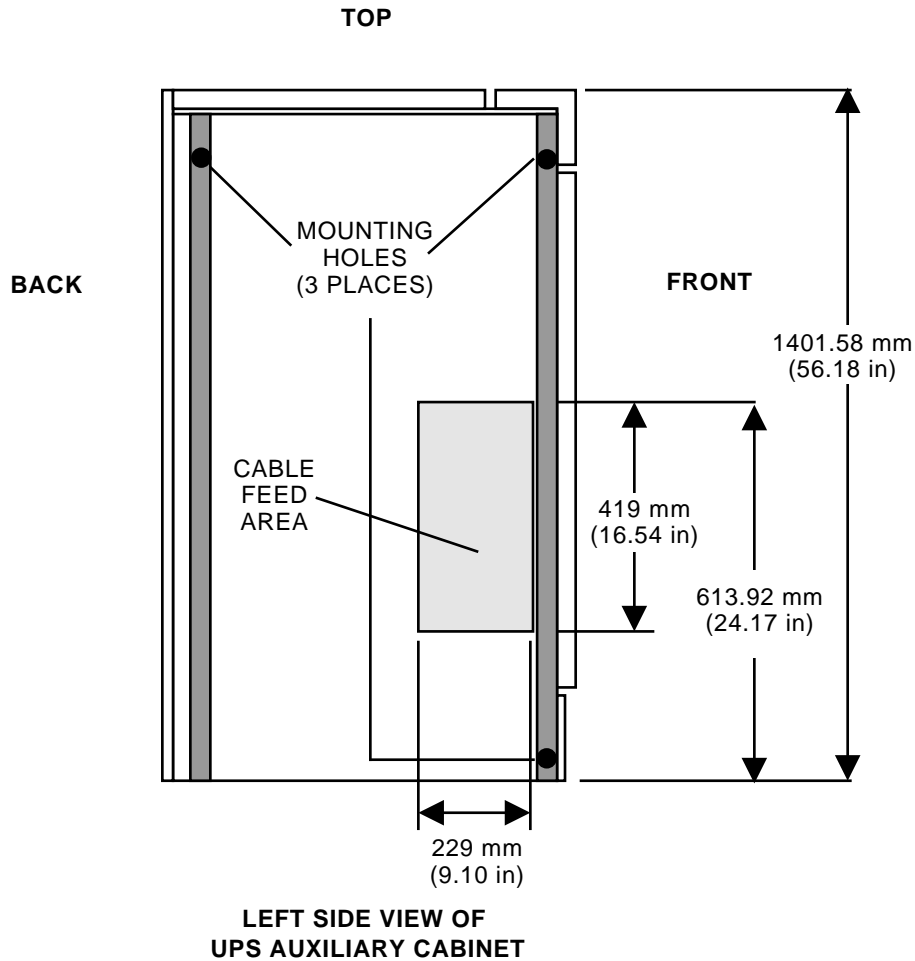

MKV-A2211-91

Figure 4-5 UPS Auxiliary Cabinet Mounting Holes

If bottom cable entry is required, the cables must be routed through the UPS cabinet bottom cable entry area (refer to Figure 2-2 or Figure 2-3). The cables must then be routed to the UPS Auxiliary Cabinet through the side openings between the UPS cabinet and the UPS Auxiliary Cabinet.

The side cable entry to the UPS cabinet and the UPS Auxiliary Cabinet can be accommodated through the right side of the UPS Auxiliary Cabinet (Figure 4-6). The UPS Auxiliary Cabinet is provided with three cable trays to run the input, output, battery, and control cables to the UPS cabinet (Figure 4-7).

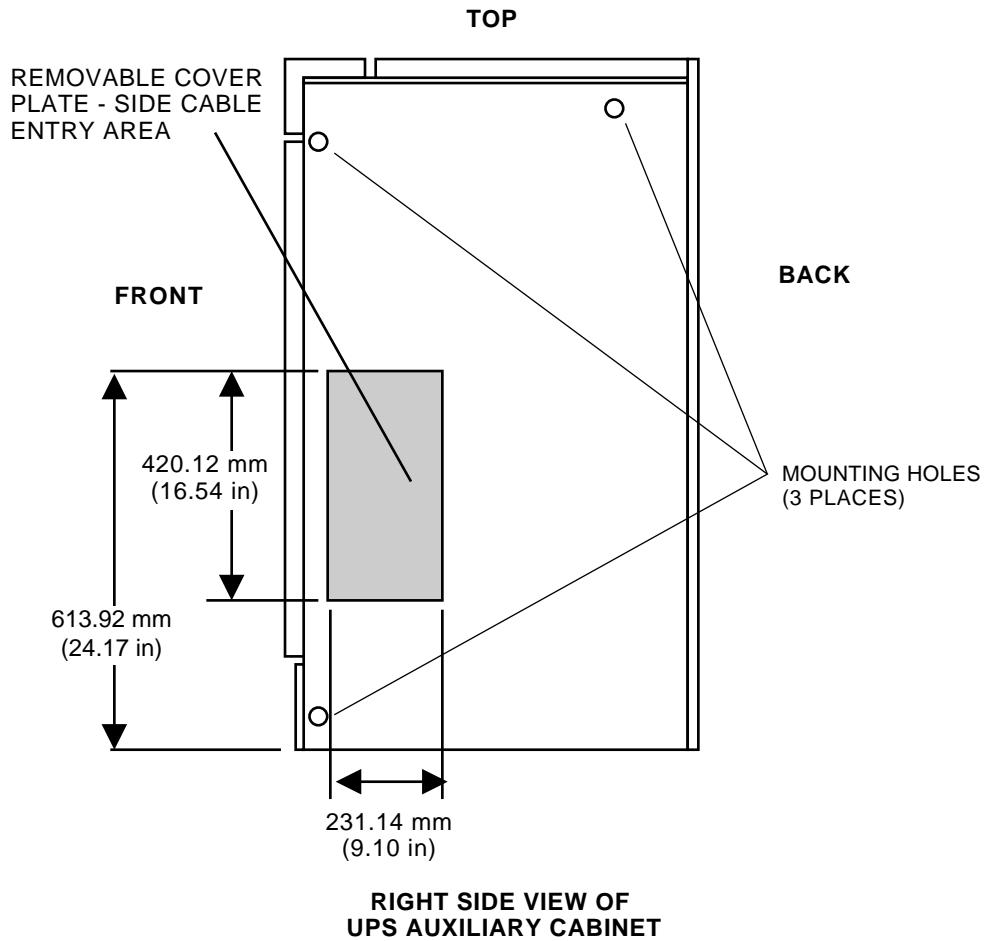

MKV-A2212-91

Figure 4-6 Right Side Cable Entry Area

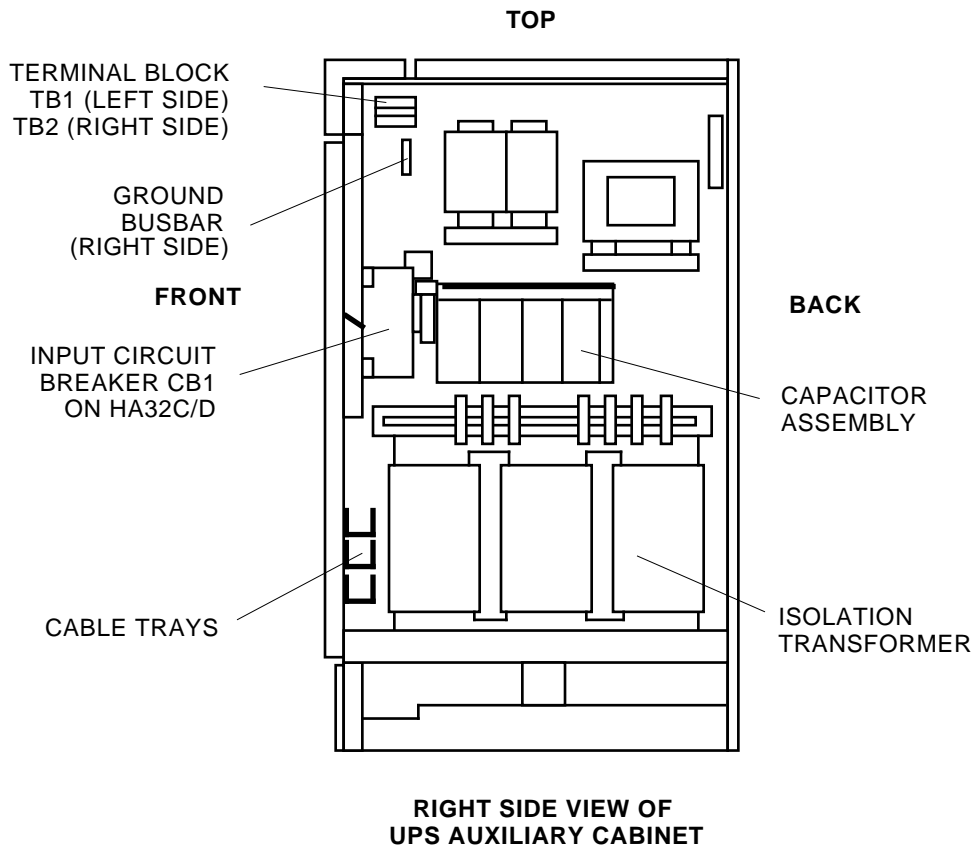

MKV-A2213-91

**Figure 4-7 UPS Auxiliary Cabinet Cable Trays**

#### 4.4.1 Power Cable Connections

The UPS Auxiliary Cabinet can accommodate two separate options: the isolation transformer and the input harmonic current filter. Each of these options has its own connection procedure.

##### 4.4.1.1 AC Input Connection for Input Isolation Transformer Option

The connections to be made are the three-phase, three wires plus equipment ground. The phase rotation must be A, B, C. Refer to Table 4-4 for the nominal ac input current at the nominal input voltage specified, and for the input circuit breaker rating (if the UPS Auxiliary Cabinet has the input isolation transformer). Size the main input cables and upstream protection devices accordingly.



**Table 4-4 HA32C/D/E UPS Auxiliary Cabinet Electrical Specifications**

<b>Model Number</b>	<b>Output Rating (kVA)</b>	<b>Input Voltage (Vac)</b>	<b>Input Current (Amps)</b>	<b>Output Voltage (Vac)</b>	<b>Output Current (Amps)</b>	<b>Input CB Rating (Amps)</b>
<b>With Input Isolation Transformer and Harmonic Current Filter</b>						
HA32C-AH	20	208	62	208	62	90
HA32C-BH	20	480	30	208	62	40
HA32C-CH	20	480	30	480	30	40
HA32C-DH	20	220	59	220	59	90
HA32C-EH	20	600	24	208	62	40
HA32C-AK	40	208	122	208	122	175
HA32C-BK	40	480	53	208	122	90
HA32C-CK	40	480	53	480	53	90
HA32C-DK	40	220	115	220	115	175
HA32C-EK	40	600	43	208	122	60
HA32C-AM	60	208	181	208	181	250
HA32C-BM	60	480	79	208	181	100
HA32C-CM	60	480	79	480	79	100
HA32C-DM	60	220	171	220	171	250
HA32C-EM	60	600	63	208	181	80
HA32C-AN	80	208	238	208	238	350
HA32C-BN	80	480	103	208	238	150
HA32C-CN	80	480	108	480	103	150
HA32C-DN	80	220	225	220	225	350
HA32C-EN	80	600	93	208	238	100
<b>With Input Isolation Transformer Only</b>						
HA32D-AH	20	208	62	208	62	90
HA32D-BH	20	480	30	208	62	40
HA32D-CH	20	480	30	480	30	40

**NOTES:**

1. NA = Not Applicable
2. The Input Harmonic Current Filter option is not voltage dependent. It does not increase the input or output current.
3. The UPS Auxiliary Cabinet models with an Input Isolation Transformer (HA32C and HA32D) contain an input circuit breaker (CB1).

**Table 4-4 (Cont.) HA32C/D/E UPS Auxiliary Cabinet Electrical Specifications**

<b>Model Number</b>	<b>Output Rating (kVA)</b>	<b>Input Voltage (Vac)</b>	<b>Input Current (Amps)</b>	<b>Output Voltage (Vac)</b>	<b>Output Current (Amps)</b>	<b>Input CB Rating (Amps)</b>
HA32D-DH	20	220	59	220	59	90
HA32D-EH	20	600	24	208	62	40
HA32D-AK	40	208	122	208	122	175
HA32D-BK	40	480	53	208	122	90
HA32D-CK	40	480	53	480	53	90
HA32D-DK	40	220	115	220	115	175
HA32D-EK	40	600	43	208	122	60
HA32D-AM	60	208	181	208	181	250
HA32D-BM	60	480	79	208	181	100
HA32D-CM	60	480	79	480	79	100
HA32D-DM	60	220	171	220	171	250
HA32D-EM	60	600	63	208	181	80
HA32D-AN	80	208	238	208	238	350
HA32D-BN	80	480	103	208	238	150
HA32D-CN	80	480	108	480	103	150
HA32D-DN	80	220	225	220	225	350
HA32D-EN	80	600	93	208	238	100
<b>With Harmonic Current Filter Only</b>						
HA32E-PH	20	NA	NA	NA	NA	NA
HA32E-PK	40	NA	NA	NA	NA	NA
HA32E-PM	60	NA	NA	NA	NA	NA
HA32E-PN	80	NA	NA	NA	NA	NA

**NOTES:**

1. NA = Not Applicable
2. The Input Harmonic Current Filter option is not voltage dependent. It does not increase the input or output current.
3. The UPS Auxiliary Cabinet models with an Input Isolation Transformer (HA32C and HA32D) contain an input circuit breaker (CB1).

Field wiring connections for the isolation transformer are made on the line side of the circuit breaker CB1. To gain access to this area, the door of the UPS Auxiliary Cabinet must be unlocked and opened, and the upper inside cover panel must be removed.

Connect the incoming  $\Phi A$  cable to the left side terminal of the circuit breaker. Connect the incoming  $\Phi B$  cable to the middle terminal of the circuit breaker. Connect the incoming  $\Phi C$  cable to the right side terminal of the circuit breaker. Connect the ground cable to the ground busbar. The cables connecting the input circuit breaker to the isolation transformer are factory installed.

The four power cables connecting the UPS Auxiliary Cabinet to the UPS cabinet are provided. These cables are connected to the isolation transformer terminals X1, X2, X3, and X0 (Figure 4-8). The other end of the cables are marked A, B, C, and N. The cables must be terminated in the UPS cabinet. A ground cable is supplied with the UPS Auxiliary Cabinet. This ground cable must be connected between the ground busbar in the UPS Auxiliary Cabinet and the ground busbar in the UPS cabinet.

Feed the four power cables through the side cable entry area and into the UPS cabinet. Connect them in one of the three configurations described in the following sections.

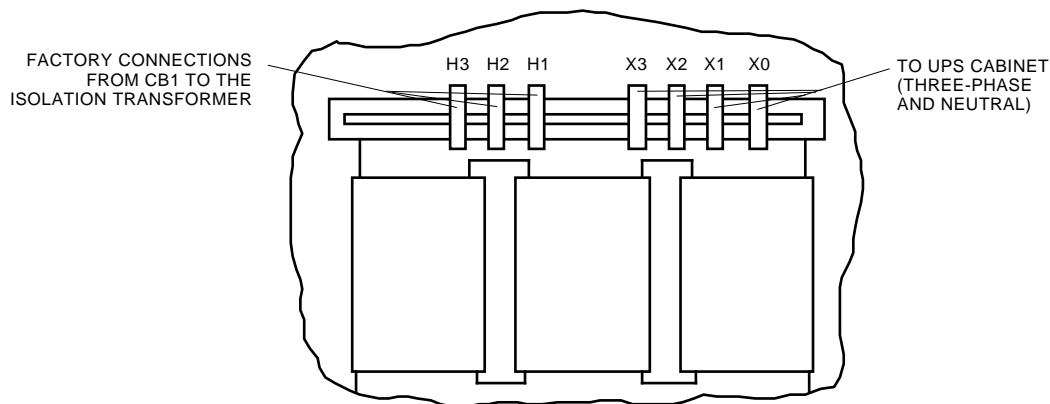

MKV-A2214-91

**Figure 4-8 Connecting the Isolation Transformer**

#### 4.4.1.2 Connecting the Isolation Transformer for Both the UPS Main AC Input (MAINS1) and Bypass AC Input (MAINS2)

Connect the four cables from the UPS Auxiliary Cabinet marked A, B, C, and N to the UPS cabinet input busbars marked A, B, C, and N, respectively (refer to Figure 4-9). The UPS main ac input (MAINS1) and bypass ac input (MAINS2) must be connected together using jumper cables.

#### NOTES

**Digital Equipment Corporation does not furnish these jumper cables for field installation.**

**Systems with a 600 Vac input always require an HA32C/D UPS Auxiliary Cabinet with the input isolation transformer supplying both the UPS main ac input (MAINS1) and the bypass ac input (MAINS2). The UPS main ac input and bypass ac input must be internally connected with jumper cables. The customer must supply one ac feeder only.**

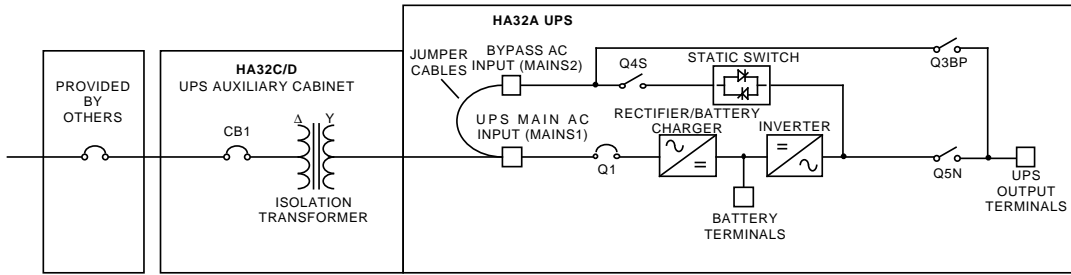

MKV-A2068-91

**Figure 4-9 UPS Input and Bypass Input Isolation Transformer Configuration**

**4.4.1.3 Connecting the Isolation Transformer for the UPS Bypass AC Input (MAINS2) Only**

Connect the four cables from the UPS Auxiliary Cabinet marked A, B, C, and N to the bypass ac input busbars marked A, B, C, and N, respectively (refer to Figure 4-10).

The input to the UPS Auxiliary Cabinet is jumpered from the main ac input (MAINS1) busbars in the UPS cabinet. This method requires one ac feeder.

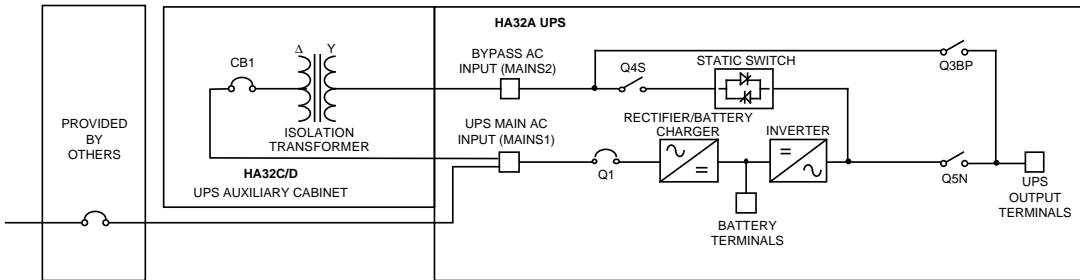

MKV-A2215-91

**Figure 4-10 UPS Bypass Input Isolation Transformer Configuration**

An alternative method for connecting the isolation transformer to the bypass ac input in the UPS cabinet is shown in Figure 4-11. This method requires two ac feeders.

**NOTE**

**A separate three-wire source must be run to the UPS main ac input (MAINS1) connections.**

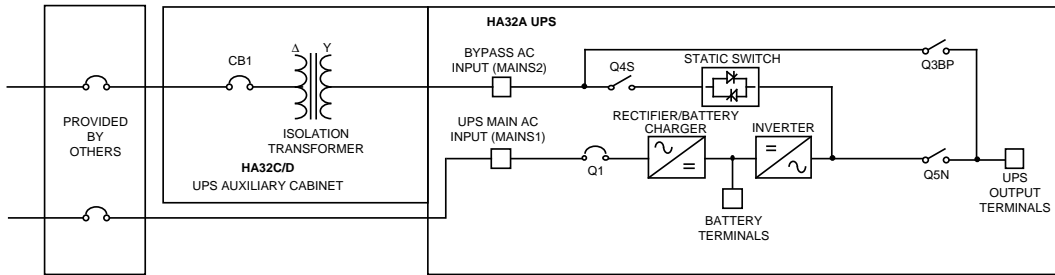

MKV-A2067-91

**Figure 4-11 Alternate UPS Bypass Input Isolation Transformer Configuration**

**4.4.1.4 Connecting the Isolation Transformer for the UPS Main AC Input (MAINS1) Only**  
 Connect the four cables from the UPS Auxiliary Cabinet marked A, B, C, and N to the UPS input busbars marked A, B, C, and N, respectively (refer to Figure 4-12).

**NOTE**

**A separate four-wire Wye source must be run to the UPS bypass ac input (MAINS2) connections if the UPS has a 208 Vac output.**

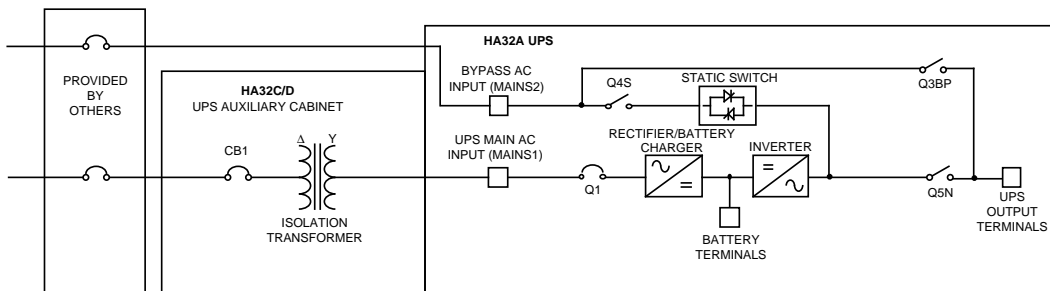

MKV-A2066-91

**Figure 4-12 UPS Input Isolation Transformer Configuration**

**4.4.1.5 Connecting the Input Harmonic Current Filter**

The six (6) cables connecting the input harmonic current filter to the HA32A UPS are supplied. The six power cables will ship separately with the HA32C/E UPS Auxiliary Cabinet. They are already connected in the UPS Auxiliary Cabinet and must be connected to the UPS cabinet. Rear access to the UPS cabinet will be required to make these connections.

The UPS cabinet internal connections must be modified to connect the input harmonic current filter. Follow this procedure:

1. Figure 4-13 shows the existing configuration of the UPS cabinet. Figure 4-14 shows the final wiring configuration of the UPS cabinet with the input harmonic current filter attached.
2. Feed the six (6) cables through the opening provided behind the input/bypass circuit breaker panel in the UPS cabinet. Make certain that you keep the cables away from any electrical part or sharp edges.
3.  $\Phi$ A Connection: Remove the cable marked A from its existing connection. Connect the two cables marked A and 1 to the 1-inch standoff insulator. Connect the cable marked 4 to the existing  $\Phi$ A inductor wire.
4.  $\Phi$ B Connection: Remove the cable marked B from its existing connection. Connect the two cables marked B and 2 to the 1-inch standoff insulator. Connect the cable marked 5 to the existing  $\Phi$ B inductor wire.
5.  $\Phi$ C Connection: Remove the cable marked C from its existing connection. Connect the two cables marked C and 3 to the 1-inch standoff insulator. Connect the cable marked 6 to the existing  $\Phi$ C inductor wire.
6. The final wiring configuration is shown in Figure 4-14.

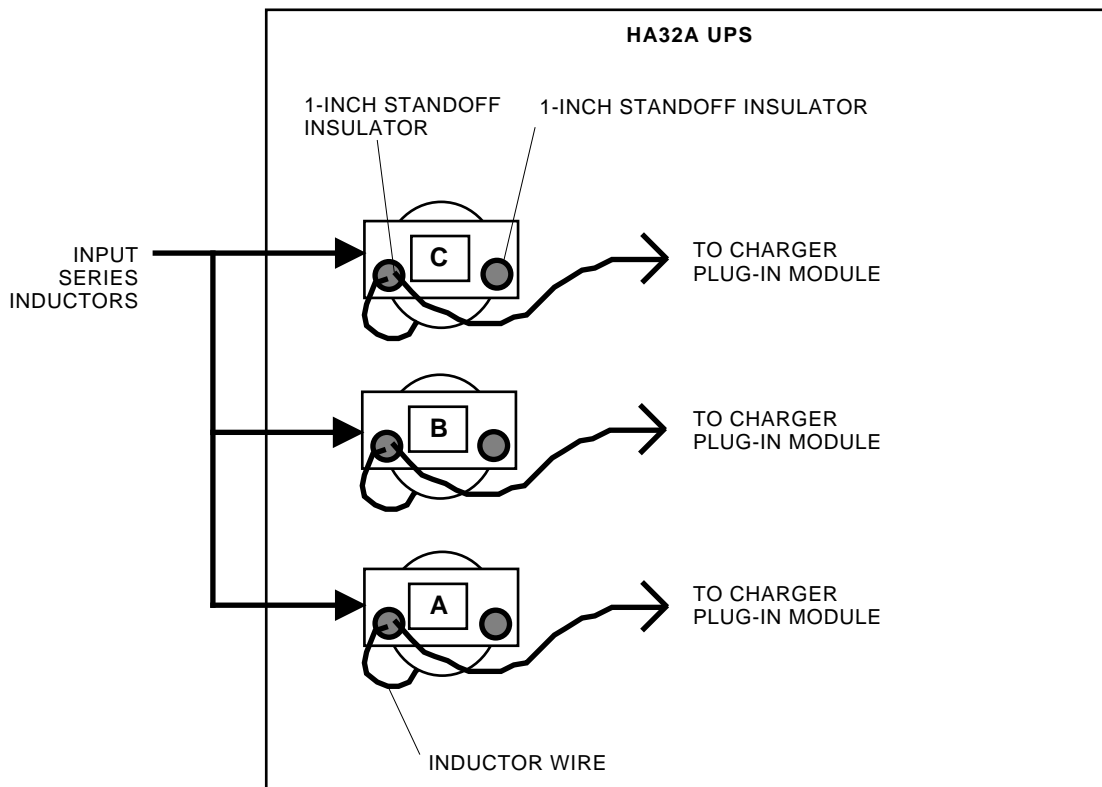

MKV-A2216-91

**Figure 4-13** UPS Cabinet Without Input Harmonic Current Filter Installed

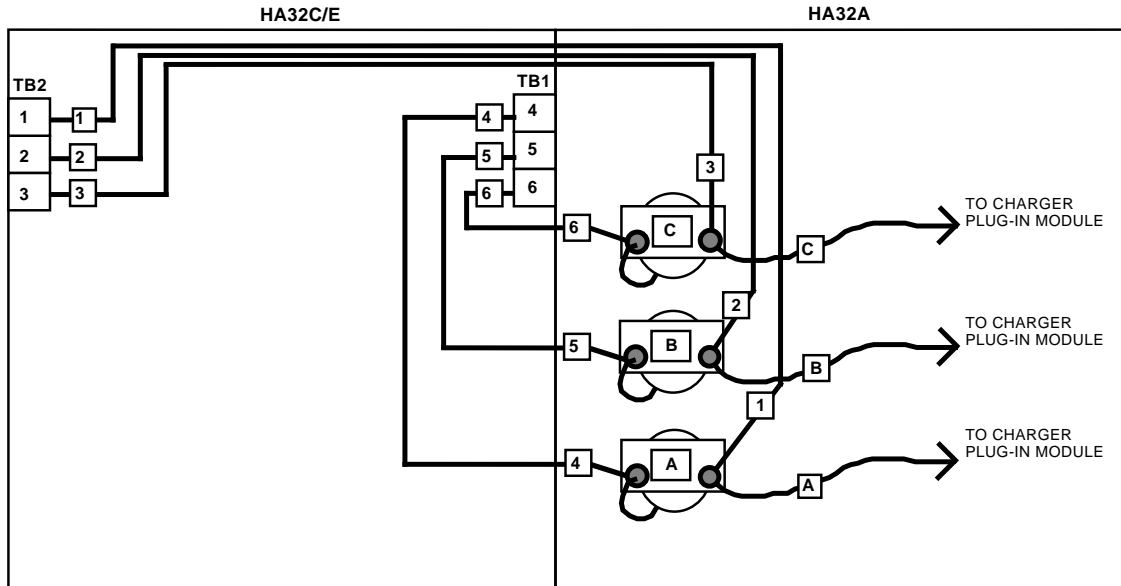

MKV-A2217-91

**Figure 4-14 UPS Cabinet with Input Harmonic Current Filter Installed**

#### 4.4.2 Control/Interface Wiring

Connect the two control wires provided with the UPS Auxiliary Cabinet to the UPS cabinet terminal block TB2, terminals 11 and 12. Terminal block TB2 is located inside the UPS cabinet, in the customer cable entry section (Figure 4-3).

#### 4.4.3 Checks After Installation

After installing the UPS Auxiliary Cabinet, make the following checks:

1. Ensure that all power and control wires have been properly connected and securely tightened.
2. Check the rating on the upstream protective devices, and make certain that they are compatible with the UPS Auxiliary Cabinet requirements.
3. Verify that the input voltage to the HA32C/D/E UPS Auxiliary Cabinet is that shown on the HA32C/D/E nameplate, located inside the door of the UPS Auxiliary Cabinet.
4. Verify that the output voltage rating of the HA32C/D/E UPS Auxiliary Cabinet is compatible with the UPS input voltage requirements (UPS main ac input and/or bypass ac input). Check both nameplates.

## 4.5 HA33D/F UPS CSA CABINET

The HA33D/F UPS CSA Cabinet is designed to attach to the right side of the UPS cabinet (Figure 2-6).

Place the UPS cabinet in its final position. Remove the right side panel and the cover plate for the side cable entry area.

### NOTE

**The side panels are not provided with the UPS CSA Cabinet. Remove the right side panel from the UPS cabinet and attach it to the right side of the UPS CSA Cabinet after installation.**

Place the HA33D/F UPS CSA Cabinet on the right side of the HA32A UPS cabinet. The two cabinets must be attached together; three holes are provided for this purpose. Two holes are accessible from the front, and the third can be reached from the top-rear of the enclosure (Figure 4-15). The bolts are provided with the HA33D/F UPS CSA Cabinet.

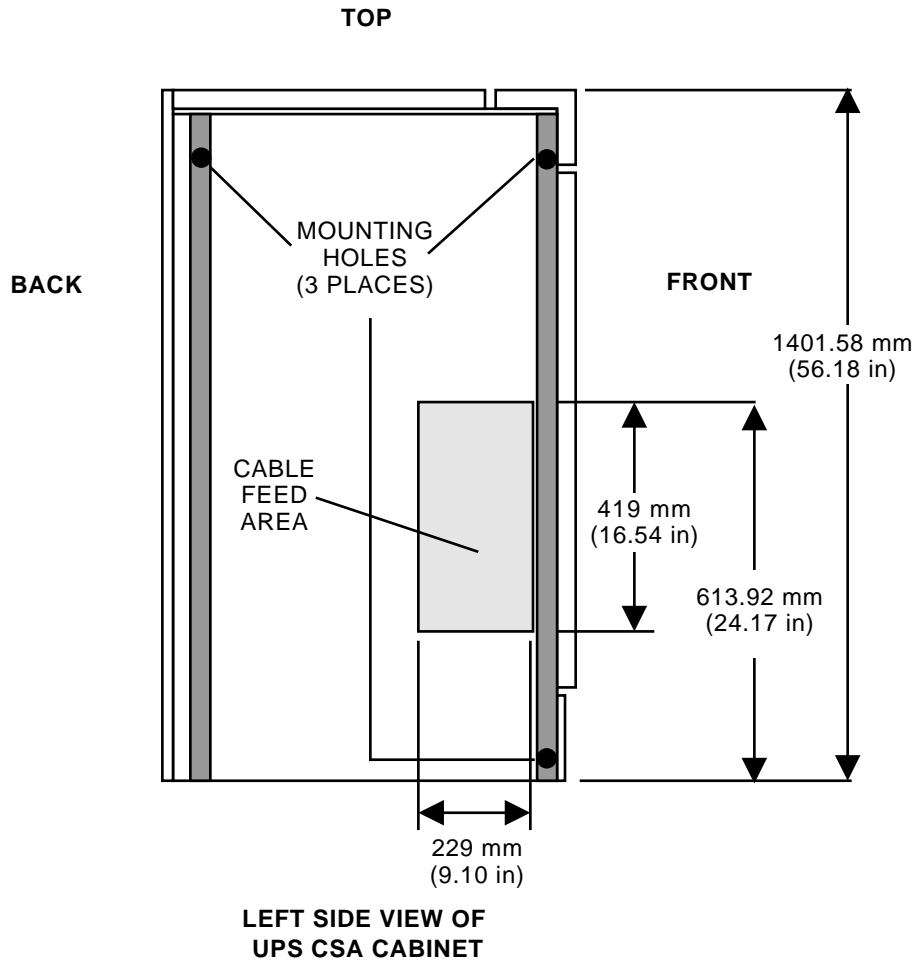

MKV-A2239-91

Figure 4-15 UPS CSA Cabinet Mounting Holes



If bottom cable entry is required, the cables must be routed through the UPS cabinet bottom cable entry area (refer to Figure 2-2 or Figure 2-3). The cables must then be routed to the UPS CSA Cabinet through the side openings between the UPS cabinet and the UPS CSA Cabinet.

The side cable entry to the UPS cabinet and the UPS CSA Cabinet can be accommodated through the right side of the UPS CSA Cabinet (Figure 4-16). The UPS CSA Cabinet is provided with three cable trays to run the input, output, battery, and control cables to the UPS cabinet.

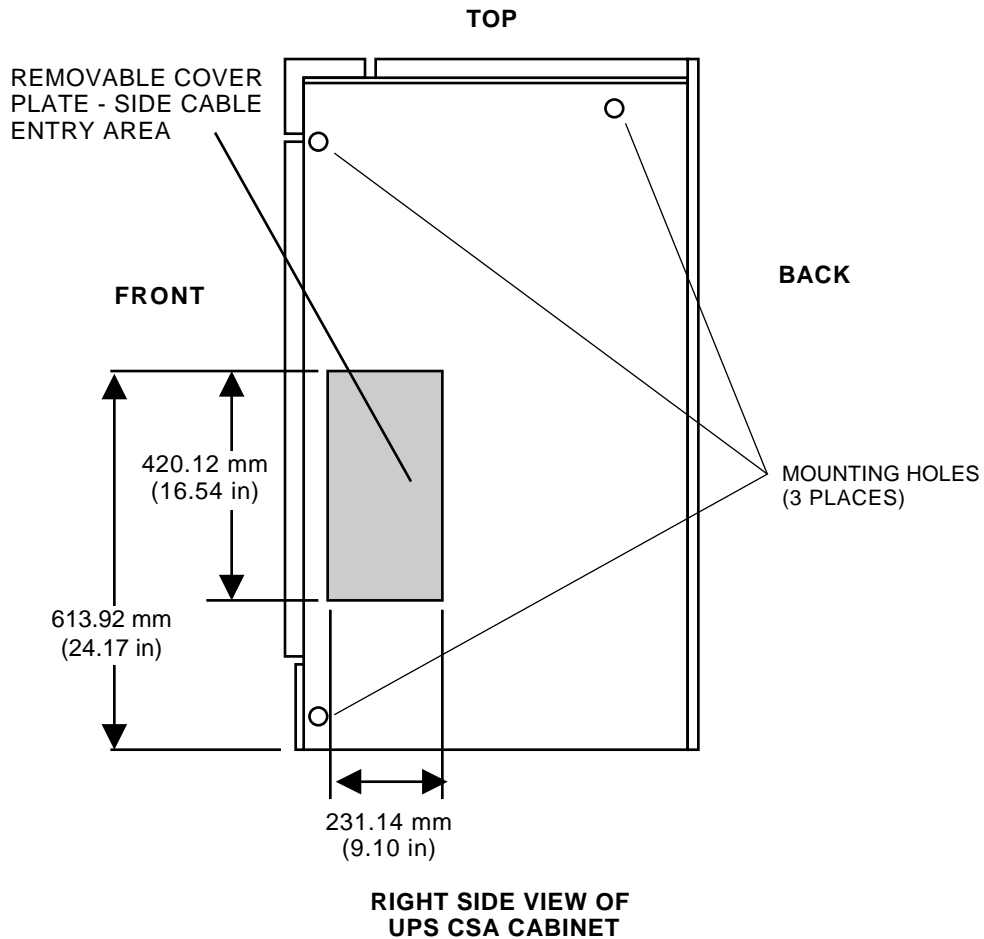

MKV-A2240-91

Figure 4-16 Right Side Cable Entry Area

### 4.5.1 Power Cable Connections

The UPS CSA Cabinet comes in two separate versions: a cabinet with an isolation/step-down transformer (600 Vac to 208 Vac) and a CSA assembly, and a cabinet with a CSA assembly. Each of these versions has its own connection procedure.

#### 4.5.1.1 Connecting the HA33D with Input Isolation/Step-Down Transformer and CSA Assembly

The connections to be made are the three-phase, three wires plus equipment ground. The phase rotation must be A, B, C. Refer to Table B-9 for the input circuit breaker rating. Size the main input cables and upstream protection devices accordingly.

**Table 4-9 HA33D/F UPS CSA Cabinet Electrical Specifications**

<b>Model Number</b>	<b>Output Rating (kVA)</b>	<b>Input Voltage (Vac)</b>	<b>Output Voltage (Vac)</b>	<b>Input CB Rating (Amps)</b>
<b>With Input Isolation/Step-Down Transformer and CSA Assembly</b>				
HA33D-EH	20	600	208	40
HA33D-EK	40	600	208	60
HA33D-EM	60	600	208	80
HA33D-EN	80	600	208	100
<b>With CSA Assembly Only</b>				
HA33F-PH	20	NA	NA	NA
HA33F-PK	40	NA	NA	NA
HA33F-PM	60	NA	NA	NA
HA33F-PN	80	NA	NA	NA

**NOTES:**

1. NA = Not Applicable
2. The CSA assembly is not voltage dependent.
3. The UPS CSA Cabinet models with an Input Isolation/Step-Down Transformer (HA33D) contain an input circuit breaker (CB1).

Field wiring connections are made on the line side of the circuit breaker CB1 (Figure 4-17). To gain access to this area, the door of the UPS CSA Cabinet must be unlocked and opened, and the upper inside cover panel must be removed.

Connect the incoming  $\Phi A$  cable to the left side terminal of the circuit breaker. Connect the incoming  $\Phi B$  cable to the middle terminal of the circuit breaker. Connect the incoming  $\Phi C$  cable to the right side terminal of the circuit breaker. Connect the ground cable to the ground busbar. The cables connecting the input circuit breaker to the isolation/step-down transformer and connecting the transformer to contactor K2 are factory installed.

The seven power cables connecting the UPS CSA Cabinet to the UPS cabinet are provided (Figure 4-17).

Four cables are connected to the isolation/step-down transformer terminals X1, X2, X3, and X0. The other end of these cables are marked A, B, C, and N. These three phase cables must be connected to the main ac input (MAINS1) terminals in the UPS cabinet, and the neutral cable must be connected to the neutral busbar in the UPS cabinet.

Three cables are connected to the load side of the mechanical contactor (K2) in the UPS CSA Cabinet. The other end of these cables are marked A, B, and C. These three phase cables must be connected to the bypass ac input (MAINS2) terminals in the UPS cabinet.

A ground cable is supplied with the UPS CSA Cabinet. This ground cable must be connected between the ground busbar in the UPS CSA Cabinet and the ground busbar in the UPS cabinet.

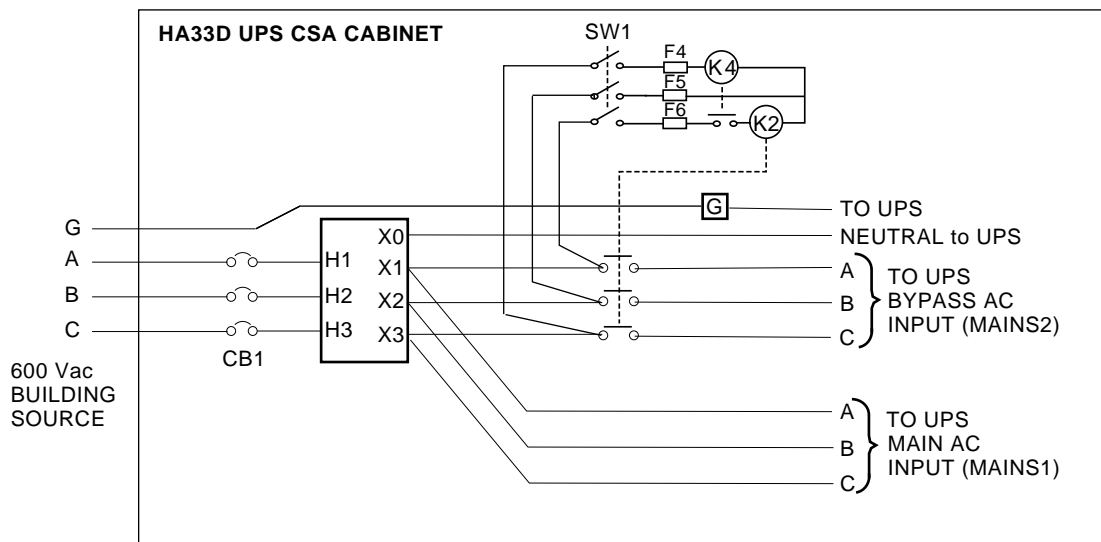

MKV-A2241-91

Figure 4-17 HA33D UPS CSA Cabinet Wiring Diagram

4.5.1.2 Connecting the HA33F with CSA Assembly Only

The connections to be made are the three-phase, four-wire Wye plus equipment ground. The phase rotation must be A, B, C. Size the main input cables and upstream protection devices according to the UPS cabinet input ratings.

Field wiring connections are made to TB4 which is located on the left-side wall of the UPS CSA Cabinet (Figure 4-18). To gain access to this area, the door of the UPS CSA Cabinet must be unlocked and opened, and the upper inside cover panel must be removed.

Connect the incoming  $\Phi A$  cable to TB4-1. Connect the incoming  $\Phi B$  cable to TB4-2. Connect the incoming  $\Phi C$  cable to TB4-3. Connect the neutral cable to the neutral busbar. Connect the ground cable to the ground busbar. The cables connecting TB4 to contactor K2 are factory installed.

The seven power cables connecting the UPS CSA Cabinet to the UPS cabinet are provided (Figure 4-18).

Three cables are connected to TB4 in the UPS CSA Cabinet. The other end of these cables are marked A, B, and C. These three phase cables must be connected to the main ac input (MAINS1) terminals in the UPS cabinet.

Three cables are connected to the load side of the mechanical contactor (K2) in the UPS CSA Cabinet. The other end of these cables are marked A, B, and C. These three phase cables must be connected to the bypass ac input (MAINS2) terminals in the UPS cabinet.

A neutral cable is connected to the neutral busbar in the UPS CSA Cabinet. The other end of this cable must be connected to the neutral busbar in the UPS cabinet.

A ground cable is supplied with the UPS CSA Cabinet. This ground cable must be connected between the ground busbar in the UPS CSA Cabinet and the ground busbar in the UPS cabinet.

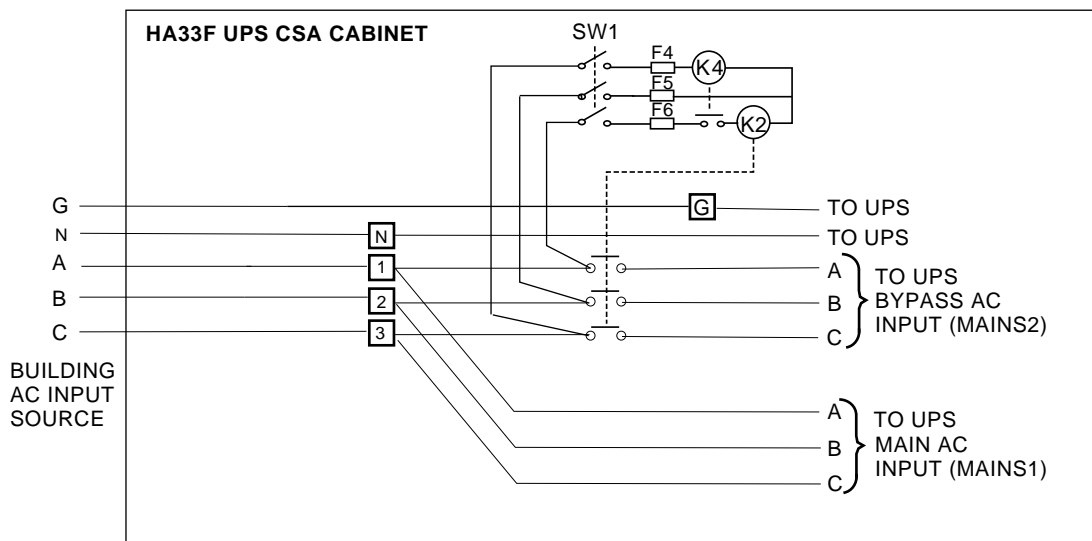

MKV-A2242-91

Figure 4-18 HA33F UPS CSA Cabinet Wiring Diagram

### 4.5.2 Control/Interface Wiring

Connect the two control wires provided with the UPS CSA Cabinet to the UPS cabinet terminal block TB2, terminals 11 and 12. Terminal block TB2 is located inside the UPS cabinet, in the customer cable entry section (Figure 4-3).

### 4.5.3 Checks After Installation

After installing the UPS CSA Cabinet, make the following checks:

1. Ensure that all power and control wires have been properly connected and securely tightened.
2. Check the rating on the upstream protective devices, and make certain that they are compatible with the UPS CSA Cabinet requirements.
3. Verify that the input voltage to the HA33D UPS CSA Cabinet is 600 Vac or that the input voltage to the HA33F UPS CSA Cabinet matches the requirement shown on the HA32A UPS nameplate, located inside the door of the UPS cabinet.
4. Verify that the output voltage of the HA33D/F UPS CSA Cabinet is compatible with the UPS input voltage requirements (UPS main ac input and/or bypass ac input). Check both nameplates.

## 4.6 HA32J/K UPS DISTRIBUTION CABINET

The HA32J/K UPS Distribution Cabinet is designed to attach to the right side of the HA32A UPS cabinet (Figure 2-7), or to the right side of the HA32C/D/E UPS Auxiliary Cabinet or HA33D/F UPS CSA Cabinet (Figure 2-8), if one or both of these options have been purchased.

### NOTE

**The side panels are not provided with the UPS Distribution Cabinet. The right side panel from the UPS cabinet, the UPS Auxiliary Cabinet, or the UPS CSA Cabinet must be removed and attached to the right side of the UPS Distribution Cabinet after installation.**

Place the HA32A UPS cabinet in its final position. Remove the right side panel and the cover plate for the side cable entry area.

If the HA32C/D/E UPS Auxiliary Cabinet or the HA33D/F UPS CSA Cabinet option is purchased, install them on the right side of the HA32A UPS cabinet.

All cabinets must be attached together; three holes are provided for this purpose (Figure 4-19). The bolts are provided with the HA32J/K UPS Distribution Cabinet.

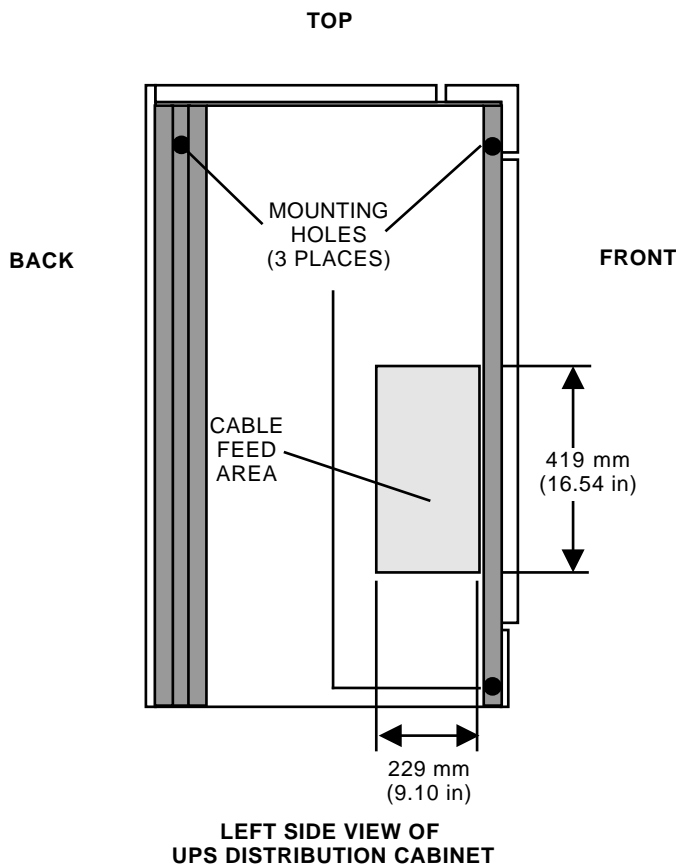

MKV-A2218-91

Figure 4-19 UPS Distribution Cabinet Mounting Holes

## 4.6.1 Power Cable Connections

The HA32J/K UPS Distribution Cabinet can be ordered with or without an isolation/step-down transformer. Regardless of the configuration, the UPS Distribution Cabinet power cables for connecting the UPS Distribution Cabinet to the UPS cabinet are factory installed in the HA32J/K UPS Distribution Cabinet.

### 4.6.1.1 AC Input Connection Without Isolation/Step-Down Transformer

The connections to be made are the three-phase, four wires plus equipment ground. The phase rotation must be A, B, C.

Feed the five (5) cables (three phases, neutral, and ground) through the side cable entry area of the UPS cabinet.

#### NOTE

**If the HA32C/D/E UPS Auxiliary Cabinet and/or the HA33D/F UPS CSA Cabinet are also installed, feed the five (5) cables through the side cable entry area of the UPS Auxiliary Cabinet and/or UPS CSA Cabinet. Run the cables on the cable tray provided in the UPS Auxiliary Cabinet and/or UPS CSA Cabinet. Then, feed the five cables through the side cable entry area of the UPS cabinet.**

The five cables connecting the HA32J/K UPS Distribution Cabinet to the HA32A UPS cabinet are marked at the end of each cable. The cables are marked A, B, and C (for the three power phases), N (for the neutral cable), and G (for the ground cable).

Connect the cables marked A, B, and C to the UPS cabinet output busbars marked A, B, and C, respectively. Connect the cable marked N to the UPS cabinet busbar marked Neutral. Connect the cable marked G to the UPS cabinet busbar marked Ground. See Figure 4-1 and Figure 4-3 for the location of these busbars.

### 4.6.1.2 AC Input Connection With Isolation/Step-Down Transformer

The connections to be made are the three-phase, three wires plus equipment ground. The phase rotation must be A, B, C.

Feed the four (4) cables (three power phases and ground) through the side cable entry area of the UPS cabinet.

#### NOTE

**If the HA32C/D/E UPS Auxiliary Cabinet and/or the HA33D/F UPS CSA Cabinet are also installed, feed the four (4) cables through the side cable entry area of the UPS Auxiliary Cabinet and/or UPS CSA Cabinet. Run the cables on the cable tray provided in the UPS Auxiliary Cabinet and/or UPS CSA Cabinet. Then, feed the four cables through the side cable entry area of the UPS cabinet.**

The four cables connecting the HA32J/K UPS Distribution Cabinet to the HA32A UPS cabinet are marked at the end of each cable. The cables are marked A, B, and C (for the three power phases), and G (for the ground cable).

Connect the cables marked A, B, and C to the UPS cabinet output busbars marked A, B, and C, respectively. Connect the cable marked G to the UPS cabinet busbar marked Ground. See Figure 4-1 and Figure 4-3 for the location of these busbars.

## 4.6.2 Control/Interface Wiring

Connect the two control wires provided with the UPS Distribution Cabinet to the UPS cabinet terminal block TB2, terminals 11 and 12. Terminal block TB2 is located inside the UPS cabinet, in the customer cable entry section (Figure 4-3).

## 4.6.3 Installation and Connection of Optional Digital Output Cables

### **WARNING**

**Potentially hazardous voltages exist within this equipment when energized. Disconnect power to the equipment before removing panels or covers, and before touching any internal elements.**

### **CAUTION**

**Output cable assemblies should only be installed or serviced by a qualified electrician.**

#### 4.6.3.1 Output Circuit Breaker Installation

Follow the procedure below to install the output circuit breakers.

1. Open both doors of the UPS Distribution Cabinet.
2. Remove the distribution panel cover by removing four (4) #10-32 screws with cup washers to expose the output circuit breaker panel.
3. Remove the front conduit cover panel by removing four (4) #10-32 screws with cup washers.
4. Remove the shipping brace located underneath the conduit plate.
5. Install the appropriate circuit breaker. Figure 4-20 shows the Square-D panelboard and Figure 4-21 shows the Bryant panelboard.



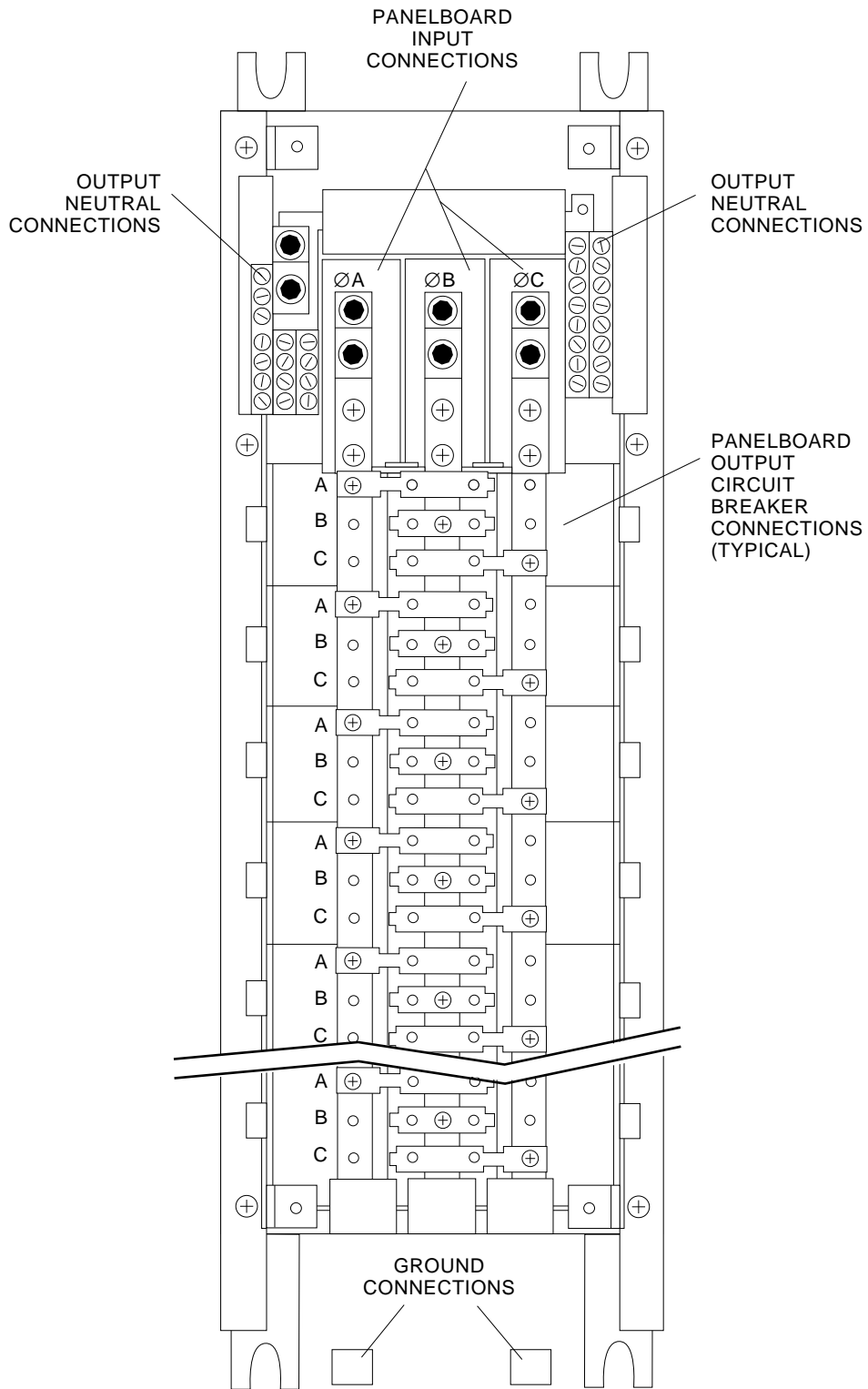

MKV-A2219-91

Figure 4-20 Square-D Distribution Panelboard

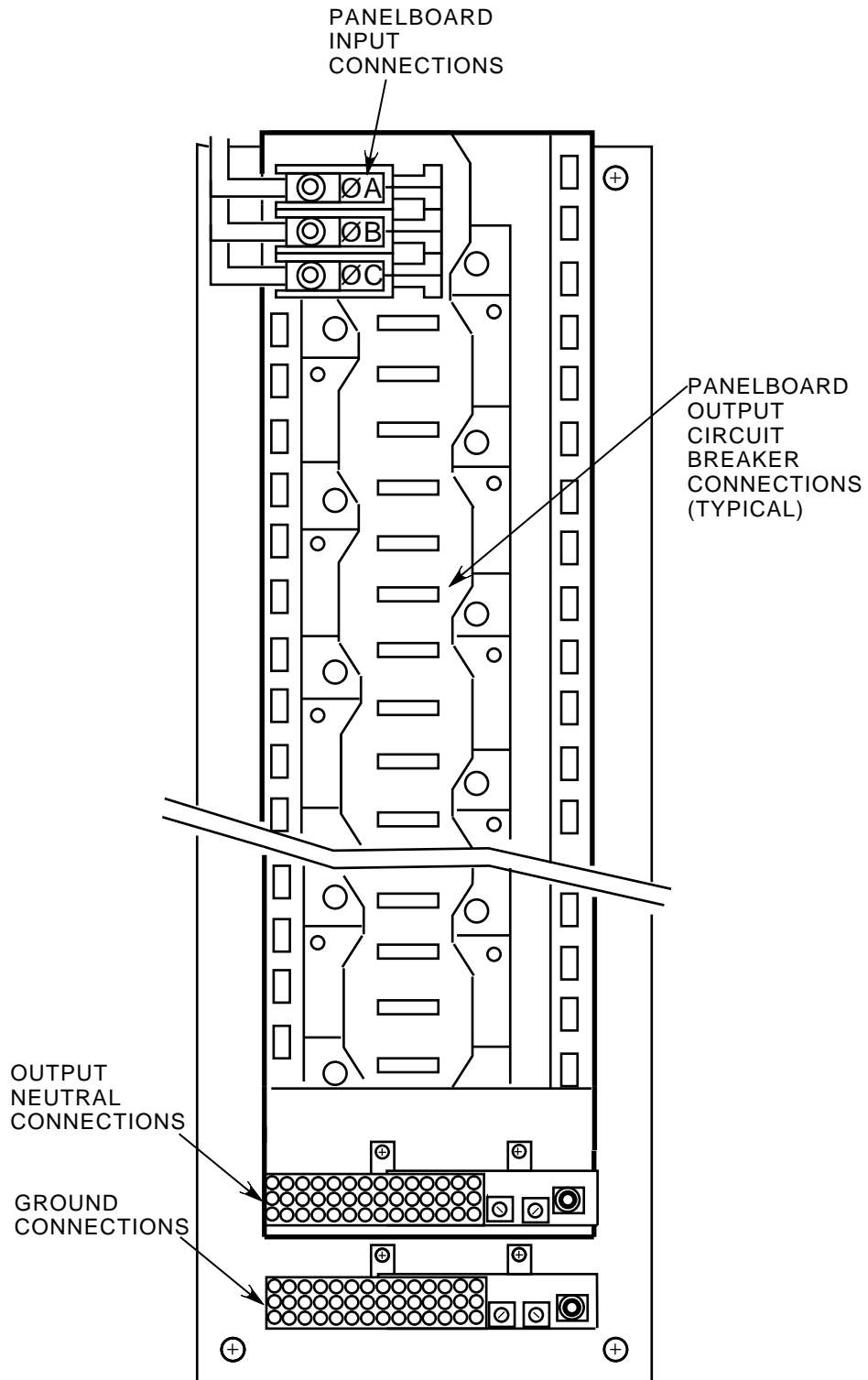

MKV-A2245-91

Figure 4-21 Bryant Distribution Panelboard

#### 4.6.3.2 Output Cable Installation

Follow the procedure below to install the output cables.

1. Remove the appropriately sized knockout plug from the conduit panel located below the panelboard.
2. Remove the locknut and bushing from the fitting at the end of the cable and use them to install the cable in the knockout hole, feeding the cable conductors through the hole.
3. Strip the insulation from the end of each cable wire, leaving 5/8-inch exposed copper wire.
4. Connect the cable wires to their respective terminations as shown in the following chart:

<b>Color</b>	<b>Signal</b>	<b>Termination</b>
White	Neutral	Neutral Bus
Black	Phase A	Top CB Terminal
Red	Phase B	Middle CB Terminal
Blue	Phase C	Bottom CB Terminal
Green	Ground	Ground Bus

#### **NOTE**

**Consult local electrical codes for color code variation.**

5. Check all connections for proper tightness.
6. Install all covers previously removed, using the original hardware.
7. **IDENTIFY THE OUTPUT CIRCUIT BREAKERS ON THE DISTRIBUTION COVER PANEL NAMEPLATE.**

#### 4.6.4 Non-Digital Output Cables

Digital employs a "Single Point Grounding Strategy" to provide a single point of reference for computing equipment. If the customer decides to purchase Digital's power distribution cable assemblies (UL Listed), the single point reference goal will be achieved by the very design and implementation of the cables.

The body of these cables are constructed of a liquid-tight flexible metal conduit. They employ an isolated ground type receptacle and a metal outlet box. The internal conductors provide the appropriate number of insulated phase conductors (receptacle dependent), an insulated neutral (receptacle dependent), and two insulated ground conductors. In the cable, one of these ground conductors is attached to the grounding lug on the receptacle and the other is attached to the metal outlet box. At the UPS Distribution Cabinet end of the cable, both ground wires are connected to the same ground busbar, the phase conductor(s) are connected to a circuit breaker, and the neutral wire is connected to the neutral busbar.

If an electrician constructs the power distribution cables, it is **HIGHLY RECOMMENDED** that these cables be of similar construction as those described in the previous paragraph to maintain Digital's "Single Point Grounding Strategy" for maximum computer system reliability.

#### **4.6.5 Checks After Installation**

After installing the UPS Distribution Cabinet, make the following checks:

1. Check that all power and control wires have been properly connected and securely tightened.
2. Verify that the input voltage to the HA32J/K UPS Distribution Cabinet is that shown on the UPS Distribution Cabinet nameplate located inside the right door of the UPS Distribution Cabinet.
3. Reinstall the distribution panel cover and the conduit cover panel.

## 4.7 HA320-AA/AB REMOTE STATUS PANEL

The Remote Status Panel allows monitoring of UPS system parameters and provides a display of alarms and diagnostic messages from up to 91.4 m (300 ft) away from the UPS cabinet.

A 7-conductor shielded cable assembly is provided with the Remote Status Panel and must be connected to TB3 in the UPS cabinet.

Use the following procedure to connect the power and control wires from the Remote Status Panel to TB3 in the UPS cabinet:

1. Route the shielded cable into the cable entry area of the UPS cabinet.
2. From the shielded cable jacket containing three 16 AWG wires, connect the green wire to TB3-1 in the UPS cabinet.
3. From the shielded cable jacket containing three 16 AWG wires, connect the white wire to TB3-3 in the UPS cabinet.
4. From the shielded cable jacket containing three 16 AWG wires, connect the black wire to TB3-2 in the UPS cabinet.
5. From the shielded cable jacket containing four (two twisted pair) 18 AWG wires, connect the black #1 wire to TB3-4 in the UPS cabinet.
6. From the shielded cable jacket containing four (two twisted pair) 18 AWG wires, connect the red #1 wire to TB3-5 in the UPS cabinet.
7. From the shielded cable jacket containing four (two twisted pair) 18 AWG wires, connect the black #2 wire to TB3-6 in the UPS cabinet.
8. From the shielded cable jacket containing four (two twisted pair) 18 AWG wires, connect the red #2 wire to TB3-7 in the UPS cabinet.

## **4.8 HA320-A3 REMOTE ALARM PANEL**

The Remote Alarm Panel allows the UPS system status to be monitored from a remote location. The unit is mounted on a wall using the four mounting holes located on the back of the unit.

For the installation of the Remote Alarm Panel option, six (6) control wires and two (2) power wires must be provided and installed by the customer's electrician.

Use the following procedure to connect the six control wires from TB3 in the Remote Alarm Panel to TB2 and TB3 in the UPS cabinet, and to connect the two power wires from a 120 Vac source to TB3 in the Remote Alarm Panel:

1. Connect a control wire from TB3-1 in the Remote Alarm Panel to TB3-12 in the UPS cabinet.
2. Connect a control wire from TB3-2 in the Remote Alarm Panel to TB2-1 in the UPS cabinet.
3. Connect a control wire from TB3-3 in the Remote Alarm Panel to TB3-9 in the UPS cabinet.
4. Connect a control wire from TB3-4 in the Remote Alarm Panel to TB2-4 in the UPS cabinet.
5. Connect a control wire from TB3-9 in the Remote Alarm Panel to TB2-2 in the UPS cabinet.
6. Connect a control wire from TB3-11 in the Remote Alarm Panel to TB3-11 in the UPS cabinet.
7. Connect the two power wires from a 120 Vac source to TB3-14 and TB3-15 in the Remote Alarm Panel.

## **4.9 HA320-C2 DC GROUND FAULT DETECTOR**

The DC Ground Fault Detector is mounted on the rear frame of the UPS Battery Cabinet.

The DC Ground Fault Detector requires two (2) control wires if it has been installed in the UPS Battery Cabinet.

Use the following procedure to connect the DC Ground Fault Detector control wires between the UPS Battery Cabinet and the UPS cabinet control wiring interface:

1. Connect a control wire from TB1-7 in the UPS Battery Cabinet to TB1-7 in the UPS cabinet.
2. Connect a control wire from TB1-8 in the UPS Battery Cabinet to TB1-8 in the UPS cabinet.

## **4.10 HA320-B1 SMOKE DETECTOR**

The Smoke Detector is mounted on the rear frame of the UPS Battery Cabinet.

The Smoke Detector requires four (4) control wires if it has been installed in the UPS Battery Cabinet.

Use the following procedure to connect the Smoke Detector control wires between the UPS Battery Cabinet and the UPS cabinet control wiring interface:

1. Connect a control wire from TB1-9 in the UPS Battery Cabinet to TB1-9 in the UPS cabinet.
2. Connect a control wire from TB1-10 in the UPS Battery Cabinet to TB1-10 in the UPS cabinet.
3. Connect a control wire from TB1-11 in the UPS Battery Cabinet to TB1-11 in the UPS cabinet.
4. Connect a control wire from TB1-12 in the UPS Battery Cabinet to TB1-12 in the UPS cabinet.



# A

## ELECTRICAL CONSIDERATIONS

---

### A.1 GENERAL

Proper grounding procedures are essential to the operation of an uninterruptible power system (UPS), personnel safety, and critical load protection. **It is the customer/customer electrician's responsibility to ensure compliance with the National Electrical Code (NEC, ANSI/NFPA 70) and applicable local codes.**

### A.2 TERMS AND DEFINITIONS

1. **Grounded conductor:** The branch of the circuit (usually the neutral) that is intentionally connected to ground. This grounded conductor is part of the current carrying circuit.
2. **Grounding conductor:** The conductor(s) that connects all exposed metal parts of the equipment to the ground. This grounding conductor is NOT part of the current carrying circuit.
3. **Separately derived source:** Article 250-5(d) of the NEC defines a separately derived source as:

A premises wiring system whose power is derived from generator, transformer, or converter windings and has no direct electrical connection, including a solidly connected grounded circuit conductor, to supply conductors originating in another system, if required to be grounded as in Article 250-5(a) or (b), shall be grounded as specified in Section 250-26.
4. **UPS classification:** Digital's UPS inverter is connected to an isolation transformer, where its secondary windings are connected in WYE configuration. The UPS requires the bypass ac input to be fed from a WYE-connected source. The neutral of this source is directly connected to the neutral of the output isolation transformer. So, the UPS may or may not be considered a separately derived source, depending on the arrangement of the bypass ac input neutral.
5. **Specific provision:** The NEC prohibits connecting the grounded circuit conductor (neutral) to the grounding conductor at more than one point. The reason is that if the neutral were connected to the grounding conductor at more than one point, some of the neutral current would be allowed to flow in the grounding conductor circuit between the points of connection. Besides being a safety hazard, this practice defeats ground fault protection schemes.



# B

## SPECIFICATIONS

---

The following are electrical and environmental specifications for the HA32A UPS.

### AC Input (MAINS1) Ratings

Refer to Table B-1 for nominal voltage (Vac) values available.

<b>Voltage:</b>	As specified, nominal +10%, -15%
<b>Frequency:</b>	Nominal, $\pm 5\%$
<b>Phases:</b>	Three-phase, phase rotation A, B, C
<b>Wires:</b>	Three, plus equipment ground
<b>Current:</b>	See Table B-2
<b>Power Factor:</b>	0.82 lagging minimum at full load output, nominal input voltage, and normal float voltage on the battery

### Bypass AC Input (MAINS2) Ratings

<b>Voltage:</b>	Must match UPS nominal output voltage $\pm 10\%$
<b>Frequency Window:</b>	Nominal, $\pm 0.25, 0.50, 0.75,$ or $1.0$ Hz. Standard setting for bypass input frequency window is $\pm 0.50$ Hz, unless otherwise specified when ordered. The frequency window can be changed after the unit is installed, but only an authorized Digital Services representative can modify the equipment.
<b>Phases:</b>	Three-phase, phase rotation A, B, C
<b>Wires:</b>	Four-wire Wye (the HA32A-Cx models do not require a Wye source or a neutral conductor)
<b>Current:</b>	See Table B-2
<b>Power Factor:</b>	Load-dependent

## B-2 SPECIFICATIONS

### Inverter AC Output Ratings

Refer to Table B-1 for nominal voltage (Vac) values available.

<b>Voltage:</b>	Nominal value $\pm 1\%$ for all conditions of line, load, and temperature
<b>Frequency:</b>	Normally synchronized to the bypass ac input source (when available); otherwise, the output frequency is the nominal value $\pm 0.1\%$
<b>Phases:</b>	Three-phase, phase rotation A, B, C
<b>Wires:</b>	Three or four. The UPS inverter output is normally a Wye configuration with the neutral grounded. A three-wire delta load can be connected to the UPS inverter output, but the phase connections cannot be grounded.
<b>Current:</b>	See Table B-2
<b>Power Factor:</b>	The UPS inverter output is rated at full kVA, 0.8 power factor lagging load
<b>Slew Rate:</b>	The rate of change of the UPS inverter output frequency, while tracking within the frequency window, when synchronizing to the bypass ac input source, or when going to a free-running condition after losing ac input power, is 1 Hz/second maximum
<b>Overload Characteristics:</b>	<p>Applies to the UPS output when operating from either the bypass ac input source or the UPS inverter output:</p> <p>125% for 10 minutes 150% for 1 minute</p> <p>Overloads in excess of 150% or exceeding the overload time periods previously indicated, will cause the load to be transferred from the UPS inverter output to the bypass ac input source, provided the sources are synchronized. Once the load is transferred to the bypass ac input source after exceeding the time periods previously indicated, the timed periods will start again for operation on the UPS static switch. If the load does not return to less than the unit's fill load rating prior to completing the timed overload periods, the load will be disconnected.</p>
<b>Dynamic Characteristics:</b>	<p>Peak voltage deviation on the UPS inverter output is listed below for the conditions indicated:</p> <p>50% step load change <math>\pm 3\%</math> maximum 100% step load change <math>\pm 5\%</math> maximum</p>
<b>Dynamic Response:</b>	The UPS inverter output voltage returns to $\pm 1\%$ of nominal within one cycle after experiencing a 100% step load change

### Battery Characteristics

<b>DC Voltage Range:</b>	325 Vdc minimum 436 Vdc maximum
<b>DC Current Required:</b>	See Table B-2

**Environmental Characteristics****Temperature:**

- **Operating Range:** 0° to 40°C (32° to 104°F), excluding battery
- **Nonoperating and Storage:** -25° to 70°C (-13° to 158°F)

**NOTE**

**Batteries should be stored only in a fully charged condition at temperatures not exceeding 25°C (77°F). Storage at higher temperatures will reduce storage life and may reduce battery life.**

**Relative Humidity:** 0 to 95%, noncondensing

**Recommended Environment:** Computer room or other temperature-controlled environment

**Recommended Temperature:** 20° to 30°C (68° to 86°F)  
Battery protection time is based on a 25°C (77°F) ambient temperature

**Recommended Relative Humidity:** 50%

## B-4 SPECIFICATIONS

The following tables contain the specifications for the HA32A UPS cabinet, the HA32B UPS Battery Cabinet, the HA32C/D/E UPS Auxiliary Cabinet, the HA33D/F UPS CSA Cabinet, and the HA32J/K UPS Distribution Cabinet.

**Table B-1 Standard HA32A UPS Models**

<b>Model Number</b>	<b>Output Rating kVA/kW</b>	<b>Nominal Input Voltage 3<math>\Phi</math> (Volts)</b>	<b>Input CB Rating (Amps)</b>	<b>Output Voltage 3<math>\Phi</math> (Volts)</b>	<b>Width mm/in</b>	<b>Approx. Weight kg/lbs</b>	<b>Heat Loss (Full Load) BTU/hr</b>
HA32A-AH	20/16	208	80	208Y/120	800/31.5	488/1,075	8,189
HA32A-DH	20/16	220	80	220Y/127	800/31.5	488/1,075	8,189
HA32A-BH	20/16	480	40	208Y/120	800/31.5	488/1,075	8,189
HA32A-CH	20/16	480	40	480Y/277	800/31.5	488/1,075	8,189
HA32A-AK	40/32	208	175	208Y/120	800/31.5	628/1,385	15,013
HA32A-DK	40/32	220	175	220Y/127	800/31.5	628/1,385	15,013
HA32A-BK	40/32	480	80	208Y/120	800/31.5	628/1,385	15,013
HA32A-CK	40/32	480	80	480Y/277	800/31.5	628/1,385	15,013
HA32A-AM	60/48	208	250	208Y/120	1,143/45.0	783/1,725	20,130
HA32A-DM	60/48	220	250	220Y/127	1,143/45.0	783/1,725	20,130
HA32A-BM	60/48	480	100	208Y/120	1,143/45.0	783/1,725	20,130
HA32A-CM	60/48	480	100	480Y/277	1,143/45.0	783/1,725	20,130
HA32A-AN	80/64	208	350	208Y/120	1,143/45.0	1,023/2,250	26,954
HA32A-DN	80/64	220	350	220Y/127	1,143/45.0	1,023/2,250	26,954
HA32A-BN	80/64	480	150	208Y/120	1,143/45.0	1,023/2,250	26,954
HA32A-CN	80/64	480	150	480Y/277	1,143/45.0	1,023/2,250	26,954

**Height, all models: 1,402 mm/55.18 in**  
**Depth, all models: 817 mm/32.18 in**

Table B-2 HA32A Currents

	HA32A-xH	HA32A-xK	HA32A-xM	HA32A-xN
<b>Output Power Rating</b>				
<b>kVA/kW</b>	20/16	40/32	60/48	80/64
<b>Unit Nominal AC Input Current (Amperes) @ Nominal Input Voltage</b>				
<b>208 Vac</b>	61.5	121.5	180.4	237.7
<b>220 Vac</b>	58.2	114.9	170.5	224.8
<b>480 Vac</b>	29.3	52.7	78.2	103.0
<b>Unit AC Output and Bypass AC Input Current (Amperes) @ Nominal Voltage (Note 1)</b>				
<b>Full Load Continuous</b>				
<b>208Y/120</b>	55.5	111.0	166.5	222.1
<b>220Y/127</b>	52.5	105.0	157.5	209.9
<b>480Y/277</b>	24.1	48.1	72.2	96.2
<b>125% Overload for 10 Minutes</b>				
<b>208Y/120</b>	69.4	138.8	208.2	277.6
<b>220Y/127</b>	65.6	131.2	196.8	262.4
<b>480Y/277</b>	30.1	60.1	90.2	120.3
<b>150% Overload for 1 Minute</b>				
<b>208Y/120</b>	83.3	166.5	249.8	333.1
<b>220Y/127</b>	78.7	157.5	236.2	314.9
<b>480Y/277</b>	36.1	72.2	108.3	144.3
<b>Maximum Battery Current (Note 2)</b>				
<b>Amperes</b>	54.6	109.2	163.9	218.5

**NOTES:**

1. As a minimum, bypass ac input (MAINS2) power should match the UPS output rating. The bypass ac input should have a continuous rating of 125% of the UPS output power rating to supply fault-clearing current.
2. Battery wiring should be sized to keep the total cable voltage drop to less than 0.5 Vdc at the current shown.

B-6 SPECIFICATIONS

**Table B-3 UPS Battery Cabinet Model Numbers**

<b>Model Number</b>	<b>kVA Rating</b>	<b>Nominal Protection in Minutes</b>	<b>Circuit Breaker (QF1) Rating in Amperes</b>	<b>Width of Battery Cabinet mm/in</b>	<b>Approx. Installed Weight kg/lbs</b>
HA32B-AH	20	5	90	800/31.5	530/1,169
HA32B-CH	20	15	90	800/31.5	530/1,169
HA32B-FH	20	30	90	1,143/45.0	905/1,995
HA32B-AK	40	5	125	800/31.5	530/1,169
HA32B-CK	40	14	125	1,143/45.0	905/1,995
HA32B-FK <sup>1</sup>	40	30	125	2 x 1,143/45.0	2 x 826/1,820
HA32B-AM	60	5	175	1,143/45.0	905/1,995
HA32B-CM <sup>1</sup>	60	10	175	2 x 1,143/45.0	2 x 826/1,820
HA32B-FM <sup>1</sup>	60	30	175	2 x 1,143/45.0	2 x 826/1,820
HA32B-AN	80	5	225	1,143/45.0	905/1,995
HA32B-CN <sup>1</sup>	80	14	225	2 x 1,143/45.0	2 x 826/1,820
HA32B-FN <sup>1</sup>	80	22	225	2 x 1,143/45.0	2 x 905/1,995

<sup>1</sup>Consists of two battery cabinets with same dimensions and weight.

**Depth of all models: 817 mm/32.18 in**  
**Height of all models: 1,402 mm/55.18 in**

**Table B-4 Maximum DC Current Requirements**

<b>UPS Battery Cabinet Model Number</b>	<b>Maximum DC Current (Amperes)</b>
HA32B-XH	54.6
HA32B-XK	109.2
HA32B-XM	163.9
HA32B-XN	218.5



**Table B-5 Interbattery Link Torque Values**

<b>Manufacturer</b>	<b>Model No.</b>	<b>Initial Torque Values</b>	<b>Subsequent Torque Values</b>
Yuasa	DM33-12	1.8 N·m (16.3 inch-pounds)	1.2 N·m (10.85 inch-pounds)
Yuasa	DM55-12	1.8 N·m (16.3 inch-pounds)	1.2 N·m (10.85 inch-pounds)
Yuasa	DM80-12	1.8 N·m (16.3 inch-pounds)	1.2 N·m (10.85 inch-pounds)
Johnson Controls	UPS12-95	3.9 N·m (35.0 inch-pounds)	3.4 N·m (30.0 inch-pounds)
Johnson Controls	UPS12-135	3.9 N·m (35.0 inch-pounds)	3.4 N·m (30.0 inch-pounds)
Johnson Controls	UPS12-225	3.9 N·m (35.0 inch-pounds)	3.4 N·m (30.0 inch-pounds)
Johnson Controls	JC12250	Not applicable	Not applicable

**Table B-6 UPS Auxiliary Cabinet Weights and Dimensions**

<b>Output Rating (kVA)</b>	<b>HA32D-XX Isolation Transformer Only (kg/lbs)</b>	<b>HA32E-PX Input Current Filter Only (kg/lbs)</b>	<b>HA32C-XX Isolation Transformer and Input Current Filter (kg/lbs)</b>
20	204/450	154/341	268/591
40	249/550	169/374	328/724
60	327/720	214/473	450/993
80	386/850	260/573	556/1,255

**Depth of all models: 817 mm/32.18 in**  
**Height of all models: 1,402 mm/55.18 in**  
**Width of all models: 477 mm/18.78 in**

**Table B-7 HA32C/D/E UPS Auxiliary Cabinet Electrical Specifications**

<b>Model Number</b>	<b>Output Rating (kVA)</b>	<b>Input Voltage (Vac)</b>	<b>Input Current (Amps)</b>	<b>Output Voltage (Vac)</b>	<b>Output Current (Amps)</b>	<b>Input CB Rating (Amps)</b>
<b>With Input Isolation Transformer and Harmonic Current Filter</b>						
HA32C-AH	20	208	62	208	62	90
HA32C-BH	20	480	30	208	62	40
HA32C-CH	20	480	30	480	30	40
HA32C-DH	20	220	59	220	59	90
HA32C-EH	20	600	24	208	62	40
HA32C-AK	40	208	122	208	122	175
HA32C-BK	40	480	53	208	122	90
HA32C-CK	40	480	53	480	53	90
HA32C-DK	40	220	115	220	115	175
HA32C-EK	40	600	43	208	122	60
HA32C-AM	60	208	181	208	181	250
HA32C-BM	60	480	79	208	181	100
HA32C-CM	60	480	79	480	79	100
HA32C-DM	60	220	171	220	171	250
HA32C-EM	60	600	63	208	181	80
HA32C-AN	80	208	238	208	238	350
HA32C-BN	80	480	103	208	238	150
HA32C-CN	80	480	108	480	103	150
HA32C-DN	80	220	225	220	225	350
HA32C-EN	80	600	93	208	238	100
<b>With Input Isolation Transformer Only</b>						
HA32D-AH	20	208	62	208	62	90
HA32D-BH	20	480	30	208	62	40
HA32D-CH	20	480	30	480	30	40

**NOTES:**

1. NA = Not Applicable
2. The Input Harmonic Current Filter option is not voltage dependent. It does not increase the input or output current.
3. The UPS Auxiliary Cabinet models with an Input Isolation Transformer (HA32C and HA32D) contain an input circuit breaker (CB1).

**Table B-7 (Cont.) HA32C/D/E UPS Auxiliary Cabinet Electrical Specifications**

<b>Model Number</b>	<b>Output Rating (kVA)</b>	<b>Input Voltage (Vac)</b>	<b>Input Current (Amps)</b>	<b>Output Voltage (Vac)</b>	<b>Output Current (Amps)</b>	<b>Input CB Rating (Amps)</b>
HA32D-DH	20	220	59	220	59	90
HA32D-EH	20	600	24	208	62	40
HA32D-AK	40	208	122	208	122	175
HA32D-BK	40	480	53	208	122	90
HA32D-CK	40	480	53	480	53	90
HA32D-DK	40	220	115	220	115	175
HA32D-EK	40	600	43	208	122	60
HA32D-AM	60	208	181	208	181	250
HA32D-BM	60	480	79	208	181	100
HA32D-CM	60	480	79	480	79	100
HA32D-DM	60	220	171	220	171	250
HA32D-EM	60	600	63	208	181	80
HA32D-AN	80	208	238	208	238	350
HA32D-BN	80	480	103	208	238	150
HA32D-CN	80	480	108	480	103	150
HA32D-DN	80	220	225	220	225	350
HA32D-EN	80	600	93	208	238	100
<b>With Harmonic Current Filter Only</b>						
HA32E-PH	20	NA	NA	NA	NA	NA
HA32E-PK	40	NA	NA	NA	NA	NA
HA32E-PM	60	NA	NA	NA	NA	NA
HA32E-PN	80	NA	NA	NA	NA	NA

**NOTES:**

1. NA = Not Applicable
2. The Input Harmonic Current Filter option is not voltage dependent. It does not increase the input or output current.
3. The UPS Auxiliary Cabinet models with an Input Isolation Transformer (HA32C and HA32D) contain an input circuit breaker (CB1).

**Table B-8 UPS CSA Cabinet Weights and Dimensions**

<b>Output Rating (kVA)</b>	<b>HA33D-XX Isolation/Step-Down Transformer and CSA Assembly (kg/lbs)</b>	<b>HA33F-XX CSA Assembly Only (kg/lbs)</b>
20	211/465	98/215
40	256/565	98/215
60	333/735	98/215
80	392/865	98/215

**Depth of all models: 817 mm/32.18 in**  
**Height of all models: 1,402 mm/55.18 in**  
**Width of all models: 477 mm/18.78 in**

**Table B-9 HA33D/F UPS CSA Cabinet Electrical Specifications**

<b>Model Number</b>	<b>Output Rating (kVA)</b>	<b>Input Voltage (Vac)</b>	<b>Output Voltage (Vac)</b>	<b>Input CB Rating (Amps)</b>
<b>With Input Isolation/Step-Down Transformer and CSA Assembly</b>				
HA33D-EH	20	600	208	40
HA33D-EK	40	600	208	60
HA33D-EM	60	600	208	80
HA33D-EN	80	600	208	100
<b>With CSA Assembly Only</b>				
HA33F-PH	20	NA	NA	NA
HA33F-PK	40	NA	NA	NA
HA33F-PM	60	NA	NA	NA
HA33F-PN	80	NA	NA	NA

**NOTES:**

1. NA = Not Applicable
2. The CSA assembly is not voltage dependent.
3. The UPS CSA Cabinet models with an Input Isolation/Step-Down Transformer (HA33D) contain an input circuit breaker (CB1).

**Table B-10 UPS Distribution Cabinet Specifications**

<b>Model Number</b>	<b>UPS Output Rating (kVA)</b>	<b>Input Voltage (Vac)</b>	<b>Maximum Input Current (Amps)</b>	<b>Output Voltage (Vac)</b>	<b>Maximum Output Current (Amps)</b>	<b>Weight (kg/lbs)</b>
HA32J-AT <sup>1</sup>	20 - 40	208/220	222	208/220	222	225/495
HA32K-AT <sup>1</sup>	60 - 80	208/220	222	208/220	222	239/525
HA32J-AH	20	208	55.5	208	55.5	352/775
HA32J-BH	20	480	24.1	208	55.5	352/775
HA32J-DH	20	220	55.5	220	55.5	352/775
HA32J-AK	40	208	111	208	111	389/855
HA32J-BK	40	480	48.1	208	111	389/855
HA32J-DK	40	220	111	220	111	389/855
HA32K-AK	40	208	111	208	111	399/880
HA32K-BK	40	480	48.1	208	111	399/880
HA32K-AM	60	208	166.5	208	166.5	461/1,015
HA32K-BM	60	480	72.2	208	166.5	461/1,015
HA32K-DM	60	220	166.5	220	166.5	461/1,015
HA32K-AN	80	208	222	208	222	516/1,135
HA32K-BN	80	480	96.2	208	222	516/1,135
HA32K-DN	80	220	222	220	222	516/1,135

<sup>1</sup>These models DO NOT contain an isolation/step-down transformer. The input voltage will equal the output voltage.

The HA32J-XX models contain one (1) 42-pole panelboard.

The HA32K-XX models contain two (2) 42-pole panelboards.

**Height, all models: 1,402 mm/55.18 in**  
**Depth, all models: 817 mm/32.18 in**  
**Width, all models: 800 mm/31.50 in**



## C

- Caster removal, 3–5
- Control wire connections
  - Battery Cabinet circuit breaker (QF1), 4–6
  - contact closure, 4–7
  - DC Ground Fault Detector, 4–6
  - Remote Alarm Panel, 4–7
  - Remote Status Panel, 4–7
  - Smoke Detector, 4–6
  - UPS Battery Cabinet, 4–5, 4–12
- Customer responsibilities, 1–1
  - delivery, 1–2
  - handling, 1–2
  - site preparation, 1–1

## D

- Digital Services responsibilities, 1–9
  - delivery, 1–10
  - handling, 1–10
  - initial startup, 1–10
  - site preparation, 1–9

## E

- Electrician responsibilities, 1–3
  - HA32A UPS Cabinet, 1–3
  - HA32B UPS Battery Cabinet, 1–4
  - HA32C/D/E UPS Auxiliary Cabinet, 1–5
  - HA32J/K UPS Distribution Cabinet, 1–7
  - HA33D/F UPS CSA Cabinet, 1–6
  - Remote Alarm Panel, 1–8

## H

- HA3000 storage, 2–1
- HA320-A3 Remote Alarm Panel
  - installation, 4–38
- HA320-AA/AB Remote Status Panel
  - installation, 4–37
- HA320-B1 Smoke Detector
  - installation, 4–40

- HA320-C2 DC Ground Fault Detector
  - installation, 4–39
- HA32A UPS
  - battery connections, 4–4
  - bypass ac input (MAINS2) connections, 4–4
  - installation, 4–1
  - main ac input (MAINS1) connections, 4–2
  - output load connections, 4–4
  - site preparation, 2–2
- HA32B UPS Battery Cabinet
  - installation, 4–9
  - power cable connections, 4–11
  - site preparation, 2–6
- HA32C/D/E UPS Auxiliary Cabinet
  - control wiring, 4–23
  - input harmonic current filter
    - connections, 4–21
    - installation, 4–14
  - power cable connections, 4–16
  - site preparation, 2–8
- HA32J/K UPS Distribution Cabinet
  - control wiring, 4–32
  - installation, 4–30
  - output cable installation, 4–35
  - output circuit breaker installation, 4–32
  - power cable connections, 4–31
  - site preparation, 2–12
- HA33D/F UPS CSA Cabinet
  - control wiring, 4–29
  - installation, 4–24
  - power cable connections, 4–26
  - site preparation, 2–10
- Handling, 3–2

## I

- Input harmonic current filter, 4–21
- Installation
  - HA320-A3 Remote Alarm Panel, 4–38
  - HA320-AA/AB Remote Status Panel, 4–37
  - HA320-B1 Smoke Detector, 4–40
  - HA320-C2 DC Ground Fault Detector, 4–39
  - HA32A UPS, 4–1

## 2 Index

### Installation (Cont.)

HA32B UPS Battery Cabinet, 4-9  
HA32C/D/E UPS Auxiliary Cabinet,  
4-14  
HA32J/K UPS Distribution Cabinet,  
4-30  
HA33D/F UPS CSA Cabinet, 4-24

HA32C/D/E UPS Auxiliary  
Cabinet, 1-5  
HA32J/K UPS Distribution  
Cabinet, 1-7  
HA33D/F UPS CSA Cabinet, 1-6  
Remote Alarm Panel, 1-8  
trucker/mover/rigger, 1-3

## R

Receiving, 3-1  
Responsibilities  
  customer, 1-1  
    delivery, 1-2  
    handling, 1-2  
    site preparation, 1-1  
Digital Services, 1-9  
  delivery, 1-10  
  handling, 1-10  
  initial startup, 1-10  
  site preparation, 1-9  
electrician, 1-3  
  HA32A UPS Cabinet, 1-3  
  HA32B UPS Battery Cabinet, 1-4

## S

Site preparation  
  HA32A UPS, 2-2  
  HA32B UPS Battery Cabinet, 2-6  
  HA32C/D/E UPS Auxiliary Cabinet,  
    2-8  
  HA32J/K UPS Distribution Cabinet,  
    2-12  
  HA33D/F UPS CSA Cabinet, 2-10

## T

Trucker/mover/rigger responsibilities, 1-3