

# **HA3000 20-80 kVA Uninterruptible Power System User Guide**

Order Number EK-HA32X-UG-002

**July 1991**

The information in this document is subject to change without notice and should not be construed as a commitment by Digital Equipment Corporation. Digital Equipment Corporation assumes no responsibility for any errors that may appear in this document.

Possession, use, duplication, or dissemination of the software described in this documentation is authorized only pursuant to a valid written license from Digital or the third-party owner of the software copyright.

No responsibility is assumed for the use or reliability of software on equipment that is not supplied by Digital Equipment Corporation.

Copyright © Digital Equipment Corporation 1991

All Rights Reserved.  
Printed in U.S.A.

The postpaid Reader's Comment Card included in this document requests the user's critical evaluation to assist in preparing future documentation.

**FCC NOTICE:** The equipment described in this manual generates, uses, and may emit radio frequency energy. The equipment has been type tested and found to comply with the limits for a Class A computing device pursuant to Subpart J of Part 15 of FCC Rules, which are designed to provide reasonable protection against such radio frequency interference when operated in a commercial environment. Operation of this equipment in a residential area may cause interference, in which case the user at his own expense may be required to take measures to correct the interference.

The DIGITAL logo is a trademark of Digital Equipment Corporation.

This document was prepared and published by Educational Services Development and Publishing, Digital Equipment Corporation.

# Contents

---

**About This Manual** vii

**Notes to the User** ix

**1 HA3000 SERIES UPS INTRODUCTION**

- 1.1 GENERAL ..... 1-1
- 1.2 SYSTEM DESCRIPTION ..... 1-2
  - 1.2.1 Rectifier/Battery Charger ..... 1-4
  - 1.2.2 Static Inverter ..... 1-4
  - 1.2.3 Static Switch ..... 1-4
  - 1.2.4 Manual Bypass ..... 1-4
- 1.3 PROGRAMMABLE CONTROLS AND INDICATORS ..... 1-6
- 1.4 BATTERY CABINET ..... 1-7
- 1.5 OPTIONS ..... 1-7
  - 1.5.1 UPS Auxiliary Cabinet ..... 1-7
  - 1.5.2 UPS CSA Cabinet (Canada Only) ..... 1-7
  - 1.5.3 UPS Distribution Cabinet ..... 1-8
  - 1.5.4 Remote Status Panel ..... 1-8
  - 1.5.5 Remote Alarm Panel ..... 1-8
  - 1.5.6 DC Ground Fault Detector ..... 1-9
  - 1.5.7 Smoke Detector ..... 1-9
  - 1.5.8 Remote Emergency Power Off (REPO) ..... 1-9

**2 HA32A UPS OPERATION**

- 2.1 GENERAL ..... 2-1
- 2.2 SYSTEM STATUS AND CONTROL PANEL (SS&CP) ..... 2-1
- 2.3 CONTROLS ..... 2-6
  - 2.3.1 Electromechanical Controls ..... 2-6
  - 2.3.2 Programmable Controls ..... 2-6
- 2.4 UPS MONITOR AND MENUS ..... 2-8
  - 2.4.1 START-UP Menu ..... 2-10
  - 2.4.2 INVERTER ON/OFF Menu ..... 2-12

2.4.3	DISPLAY CONTRAST Menu	2-14
2.4.4	BATT TRANS. TEST Menu	2-15
2.4.5	BYPASS PROCEDURE Menu	2-17
2.4.6	COMMANDS Menu	2-20
2.4.6.1	Rectifier/Battery Charger Start and Stop	2-20
2.4.6.2	Inverter Start and Stop	2-21
2.4.6.3	Resetting Faults Stored in Memory	2-21
2.4.6.4	Synchronous/Nonsynchronous Operation	2-21
2.4.6.5	Battery Boost Charge	2-22
2.4.6.6	Battery Equalization Charge	2-22
2.4.6.7	Language Selection	2-23
2.4.7	DIAGNOSIS Menu	2-24
2.4.8	PERSONALIZATION Menu	2-28
2.4.9	COMMUNICATION Menu	2-28
2.5	OPERATING MODES	2-29
2.5.1	Automatic Operating Sequences	2-29
2.5.1.1	Normal Operation	2-29
2.5.1.2	On Battery Operation	2-30
2.5.1.3	Input Power Restored/Battery Charging	2-31
2.5.1.4	UPS Inverter Shutdown or Major Overload	2-31
2.5.2	Manual Operating Sequences	2-32
2.5.2.1	Rectifier/Battery Charger Start or Stop	2-32
2.5.2.2	UPS Inverter Start or Stop	2-32
2.5.2.3	UPS Manual Bypass	2-33
2.5.2.4	Returning the UPS to Normal Operation from Manual Bypass	2-33
2.6	ALARMS	2-34
2.6.1	Minor Alarms	2-34
2.6.2	Major Alarms	2-35
2.6.2.1	Rectifier/Battery Charger Major Alarms	2-35
2.6.2.2	Inverter Major Alarms	2-36

### **3 HA32B UPS BATTERY CABINET**

3.1	INTRODUCTION	3-1
3.1.1	General Description	3-2
3.1.2	Specifications	3-2
3.1.3	Protection Period	3-2
3.2	OPERATION	3-3
3.2.1	Battery Disconnect Circuit Breaker QF1	3-3
3.2.1.1	Normal Operation	3-3
3.2.1.2	QF1 Trip	3-3
3.2.1.3	QF1 Reset	3-3
3.2.2	Emergency Power Off (EPO)	3-3

## 4 HA32C/D/E UPS AUXILIARY CABINET

4.1	INTRODUCTION .....	4-1
4.1.1	General Description .....	4-1
4.1.2	Input Circuit Breaker (CB1) .....	4-3
4.2	OPERATION .....	4-4
4.2.1	Input Circuit Breaker (CB1) .....	4-4
4.2.2	Input Isolation Transformer .....	4-4
4.2.3	Input Harmonic Current Filter .....	4-4

## 5 HA33D/F UPS CSA CABINET

5.1	INTRODUCTION .....	5-1
5.1.1	General Description .....	5-1
5.1.2	Contactor Control Switch (SW1) .....	5-2
5.1.3	Input Circuit Breaker (CB1) .....	5-2
5.2	OPERATION .....	5-3
5.2.1	Input Circuit Breaker (CB1) .....	5-3
5.2.2	Contactor Control Switch (SW1) .....	5-3
5.2.3	Input Isolation/Step-Down Transformer .....	5-3

## 6 HA32J/K UPS DISTRIBUTION CABINET

6.1	INTRODUCTION .....	6-1
6.1.1	System Description .....	6-2
6.2	OPERATION .....	6-3
6.2.1	Circuit Breaker(s) CB1, CB2, and CB3 .....	6-3
6.2.2	Output Circuit Breaker(s) .....	6-4

## A SPECIFICATIONS

## GLOSSARY

## Index

## Figures

1-1	HA32A UPS .....	1-1
1-2	HA3000 UPS Layout Diagram .....	1-2
1-3	HA32A UPS Single-Line Diagram .....	1-3
1-4	System Status and Control Panel (SS&CP) .....	1-6
2-1	System Status and Control Panel (SS&CP) .....	2-1
2-2	Voltage Measurements .....	2-3
2-3	Current Measurements .....	2-4
2-4	HA32A UPS .....	2-7
2-5	Normal Operation Power Flow .....	2-29

2-6	On Battery Operation Power Flow . . . . .	2-30
2-7	UPS Inverter Shutdown or Major Overload Power Flow . . . . .	2-31
2-8	UPS Manual Bypass Power Flow . . . . .	2-33
3-1	HA32B UPS Battery Cabinet . . . . .	3-1
4-1	UPS Input Isolation Transformer Configuration . . . . .	4-1
4-2	Bypass Input Isolation Transformer Configuration . . . . .	4-2
4-3	UPS Input and Bypass Input Isolation Transformer Configuration . . . . .	4-2
5-1	CSA Assembly Only Configuration . . . . .	5-1
5-2	CSA Assembly and Isolation/Step-Down Transformer Configuration . . . . .	5-2
6-1	HA32J/K UPS Distribution Cabinet . . . . .	6-1
6-2	HA32J/K and HA32A Single-Line Diagram . . . . .	6-2
6-3	HA32J/K Circuit Breaker Locations . . . . .	6-3

## Tables

2-1	Minor Alarm Messages . . . . .	2-34
2-2	Rectifier/Battery Charger Major Alarm Messages . . . . .	2-36
2-3	Inverter Major Alarm Messages . . . . .	2-36
A-1	Standard HA32A UPS Models . . . . .	A-4
A-2	HA32A Currents . . . . .	A-5
A-3	UPS Battery Cabinet Model Numbers . . . . .	A-6
A-4	Maximum DC Current Requirements . . . . .	A-6
A-5	Interbattery Link Torque Values . . . . .	A-7
A-6	UPS Auxiliary Cabinet Weights and Dimensions . . . . .	A-7
A-7	HA32C/D/E UPS Auxiliary Cabinet Electrical Specifications . . . . .	A-8
A-8	UPS CSA Cabinet Weights and Dimensions . . . . .	A-10
A-9	HA33D/F UPS CSA Cabinet Electrical Specifications . . . . .	A-10
A-10	UPS Distribution Cabinet Specifications . . . . .	A-11

## About This Manual

---

### OVERVIEW

This manual is intended for users of the HA3000 20-80 kVA series Uninterruptible Power System (UPS). It provides a general introduction to the UPS and available options, and detailed information on system controls and operation.

### WARNING

**This unit contains no user-serviceable parts. Only the key-locked doors should be opened to gain access to the circuit breakers. No other doors should be opened or covers removed, for any reason, by untrained personnel. If this unit is in need of repair, only qualified personnel familiar with safety procedures for electrical equipment and this product should access components inside the unit.**

### WARNING

**The HA32B UPS Battery Cabinet contains batteries that are wired together to produce a high voltage. Even with no external connections, hazardous voltage exists inside the UPS Battery Cabinet that can cause severe burns or death upon contact.**

### WARNING

**To stop this unit from delivering power in the event of an emergency, press both Emergency Power Off (EPO) keys simultaneously on the System Status and Control Panel. See Figure 2-1.**

The manual covers the following topics:

- Chapter 1 provides a general system description of the HA32A UPS and a description of the options available for use with the HA32A UPS.
- Chapter 2 provides detailed information on the operation of the system status and control panel, the electromechanical and programmable controls, the UPS monitor and available menus, the automatic and manual operating modes, and the alarm conditions and their causes.
- Chapter 3 provides a general description and operating procedures for the UPS Battery Cabinet.
- Chapter 4 provides a general description and operating information for the UPS Auxiliary Cabinet.
- Chapter 5 provides a general description and operating information for the UPS CSA Cabinet.
- Chapter 6 provides a general description and operating information for the UPS Distribution Cabinet.
- Appendix A provides specifications for the HA3000 series equipment.
- The Glossary provides a glossary of terms and abbreviations used in this manual.

#### RELATED DOCUMENTS

<b>Title</b>	<b>Part Number</b>
<i>HA3000 20-80 kVA Uninterruptible Power System Installation Manual</i>	EK-HA32X-IN
<i>HA3000 20-80 kVA Uninterruptible Power System Installation Drawings</i>	EK-HA32X-ID
<i>HA3000 20-80 kVA Uninterruptible Power System Handling Instructions</i>	EK-HA32X-HI



## Notes to the User

---

**The purpose of the HA3000 UPS is to provide short-term power outage protection for the critical load.**

**The protection time will vary depending upon the size of the load, the charge condition of the batteries, the temperature, and the amount of battery time purchased.**

**For extended power outages, operators wishing to initiate an orderly shutdown should be aware of the battery time available on their system. If an orderly shutdown is desired, ensure that the shutdown procedure is started with enough time left on battery operation to complete the shutdown.**

**Registered customers that need assistance with the operation of their HA3000 UPS can call 1-800-272-2001.**



# HA3000 SERIES UPS INTRODUCTION

---

## 1.1 GENERAL

This chapter introduces the HA3000 series of UPS products rated 20 to 80 kVA. It describes the UPS system, introduces controls and indicators, and describes available options. Figure 1-1 shows the HA32A UPS.

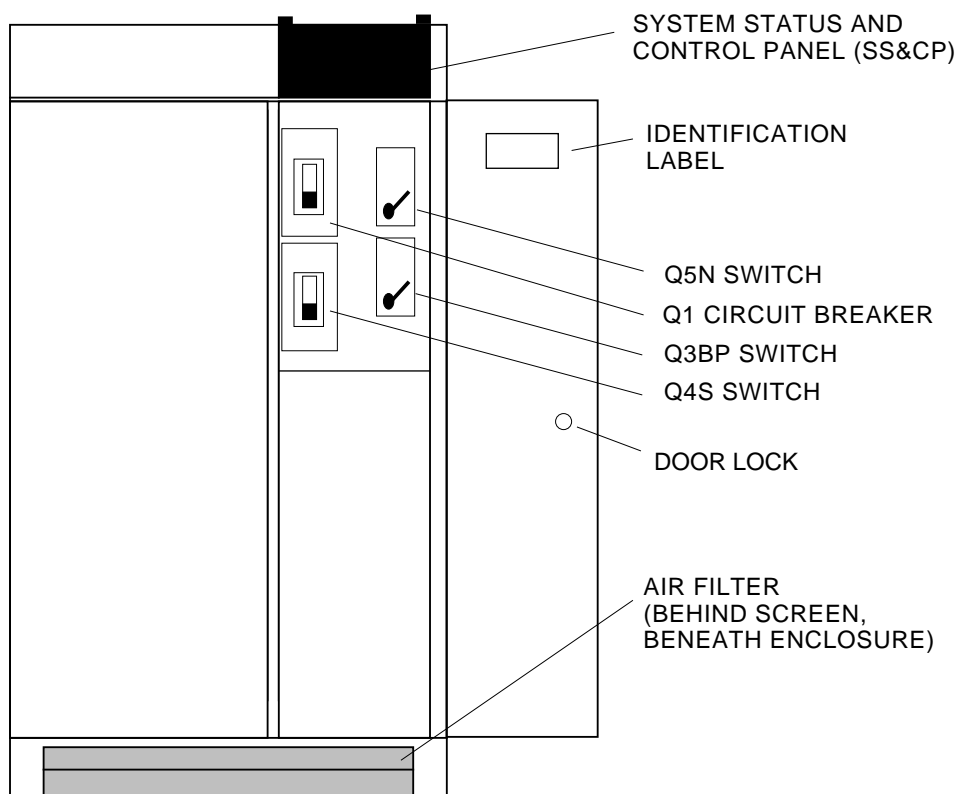

MKV-A2056-91

Figure 1-1 HA32A UPS

## 1.2 SYSTEM DESCRIPTION

The HA3000 series Uninterruptible Power System (UPS) is a three-phase on-line interface between a building's utility power distribution system and the customer's critical load. The UPS is designed to ensure a continuous flow of clean electrical power to critical loads by addressing common power problems associated with utility ac power. These problems include spikes, electrical noise, sags, brownouts, surges, dropouts, and frequency variations. In the event of a power outage, the UPS will provide battery power that is adequate to complete an orderly shutdown of equipment or to turn on a generator.

The HA3000 series UPS is available in kVA ratings of 20, 40, 60, and 80 kVA and can accept three-phase input power of 208, 220, 480, and 600 Vac.

The basic HA3000 series UPS consists of a HA32A UPS and a HA32B UPS Battery Cabinet. Options available to expand the HA3000 series UPS include the HA32C/D/E UPS Auxiliary Cabinet, the HA32J/K UPS Distribution Cabinet, the HA33D/F UPS CSA Cabinet, the HA320-Ax Remote Status Panel, the HA320-A3 Remote Alarm Panel, the HA320-B1 Smoke Detector, and the HA320-C2 DC Ground Fault Detector. Figure 1-2 shows a typical layout diagram of the HA3000 series UPS.

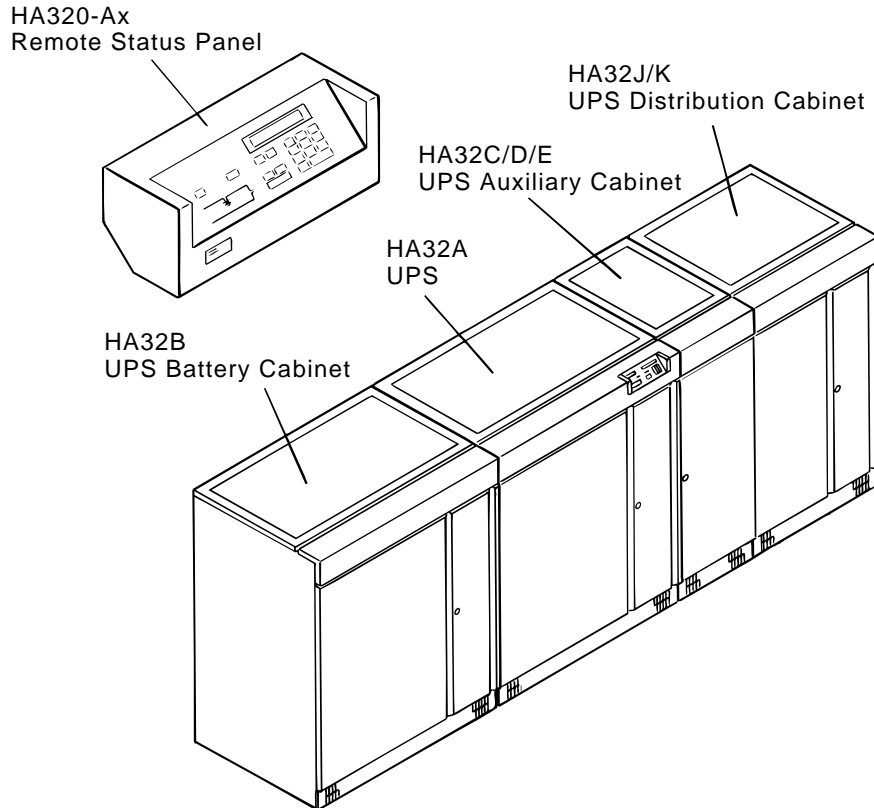

MKV-A2078-91

**Figure 1-2 HA3000 UPS Layout Diagram**

The HA32A UPS and its auxiliary equipment are listed by Underwriter's Laboratories, Inc. (UL). The addition of a CSA listed HA33D/F cabinet makes the HA32A UPS CSA compliant.

The major components of the HA32A UPS include:

- A rectifier/battery charger
- A transistorized pulse-width modulated (PWM) static inverter
- A continuous-duty rated static switch that automatically transfers the load to and from the bypass ac input source and the UPS inverter output
- An internal manual bypass function comprised of three separate switches that allows the critical load to be operated from the utility source
- A battery system housed in an external matching enclosure

The HA32A UPS uses microprocessors to control operation of the rectifier/battery charger; transistorized pulse-width modulated (PWM) static inverter; and continuous-duty rated static switch to ensure optimum performance for all line, load, and operating conditions. In addition, a microprocessor-based diagnostic system assists in troubleshooting faulty assemblies for replacement in order to minimize service time. Modular construction throughout the HA32A UPS facilitates maintenance of the system.

A system status and control panel (SS&CP) provides controls to select system operation, and indicators that allow system performance to be monitored. A liquid-crystal display (LCD) is used to display system operating parameters and step-by-step operating instructions to the system operator, and to provide a diagnostic capability to assist in troubleshooting. The built-in UPS monitor software is programmed to display messages in five languages—English, French, German, Spanish, and Italian.

A single-line diagram of the HA32A UPS is shown in Figure 1-3.

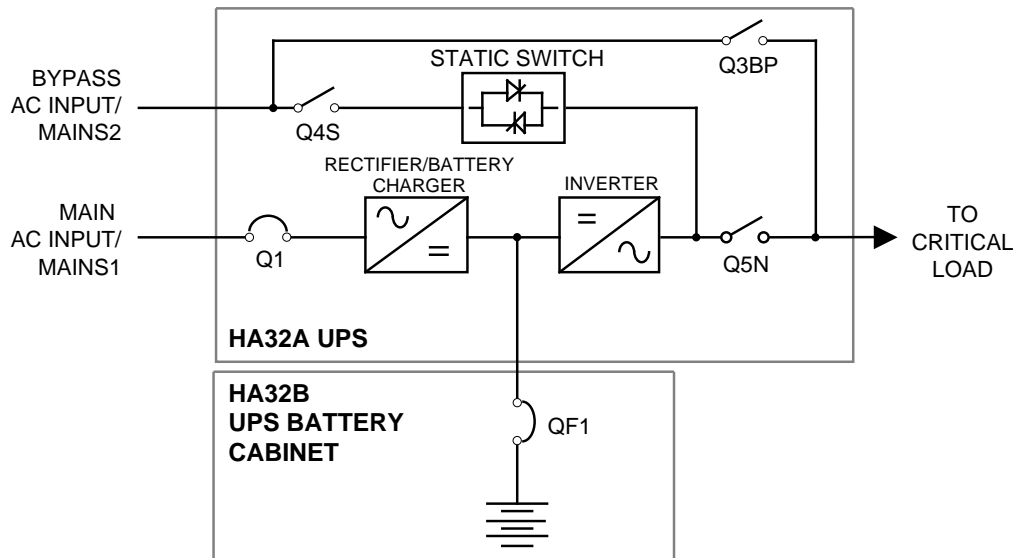

MKV-A2057-91

**Figure 1-3 HA32A UPS Single-Line Diagram**

### 1.2.1 Rectifier/Battery Charger

The rectifier/battery charger consists of:

- **AC Input Circuit Breaker (Q1):** The ac input circuit breaker provides mechanical isolation and electrical protection for the input of the UPS.
- **Input Autotransformer:** The input autotransformer is used to match the external ac input source to that required internally for the UPS.
- **Power Module:** The power module is a plug-in unit that converts incoming ac power to a regulated dc output voltage. The regulation is carried out by controlling the SCR conduction angles, allowing the rectifier/battery charger to supply a stable dc voltage ( $\pm 1\%$ ). The dc voltage is filtered by a capacitor bank.
- **DC Shunt:** The dc shunt is used to monitor the battery charge current and provide data for regulating the dc voltage at the desired level. Battery current is normally limited to  $0.1C_{10}$  (that is, 1/10th of the battery capacity specified for a 10-hour discharge rate).

### 1.2.2 Static Inverter

The static inverter consists of:

- **Power Module:** The power module is a plug-in unit, used to chop the dc voltage to obtain the PWM waveform at the primary of the output transformer. A single power module is used for UPS systems having an output rating of 20 kVA. UPS systems rated above 20 kVA use three power modules, one module per phase.
- **Inverter Transformer:** The inverter transformer is a full-isolation transformer that provides input/output electrical isolation for the UPS, the required output voltage, and the required inductance for the ac output filter.
- **AC Output Filter:** The ac output filter is used to achieve a computer-grade sine wave output voltage waveform, with a total harmonic distortion (THD) of 4% maximum (3% typical).

### 1.2.3 Static Switch

The static switch transfers the load from the UPS inverter output to the bypass ac input source or from the bypass ac input source to the UPS inverter output, without any interruption to the load (provided that the UPS inverter output is synchronized to the bypass ac input source). These transfers take place automatically upon inverter startup or shutdown. The static switch is rated for continuous duty, and is of plug-in construction for easy maintenance.

The delta-RC network protects the static switch against high-voltage spikes and surges by absorbing the excess energy. The delta-RC circuit network is protected by fuses, and any failure of these fuses is displayed on the SS&CP LCD.

### 1.2.4 Manual Bypass

The internal manual bypass function consists of three switches that, when operated as specified, provide a make-before-break transfer of the load from the UPS inverter output to the bypass ac input source or from the bypass ac input source to the UPS inverter output. This feature allows the critical load to be operated from the utility power source.

The three internal manual bypass nonautomatic switches are designated as:

- Bypass (MAINS2) Input (Q4S)
- UPS Output Isolation (Q5N)
- Manual Bypass (Q3BP)

For startup or shutdown of the equipment, correct operation of the three switches is shown on the liquid-crystal display (LCD), which is located on the system status and control panel (SS&CP).

### 1.3 PROGRAMMABLE CONTROLS AND INDICATORS

All HA32A programmable controls (excluding circuit breakers and nonautomatic switches) and indicators are located on the system status and control panel (SS&CP), which is shown in Figure 1-4. The SS&CP contains the elements listed below:

- Liquid-Crystal Display (LCD)
- Silence Audible Alarm Key
- Alarm LED
- Scroll Up Key
- Scroll Down Key
- Ten-Digit (0 to 9) Keypad
- Rectifier/Battery Charger LED
- Inverter LED
- Load On Bypass LED
- Voltage Measurement Key
- Current Measurement Key
- Main Menu Display Key
- Enter/Validation or Return To Menu Key
- Emergency Power Off (EPO) Keys

Detailed descriptions and uses of the SS&CP indicators are provided in Chapter 2.

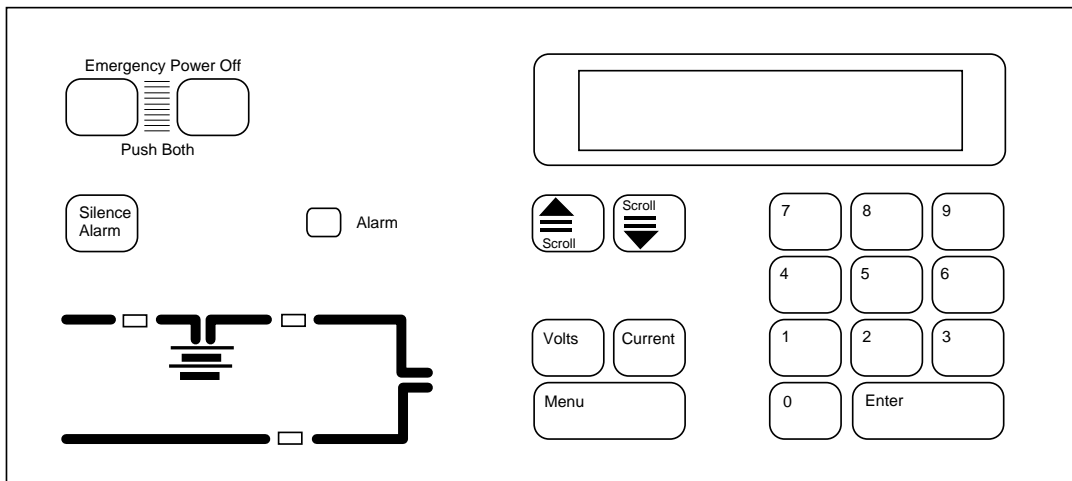

MKV-A2058-91

**Figure 1-4 System Status and Control Panel (SS&CP)**



## 1.4 BATTERY CABINET

Each HA32A UPS requires a separate HA32B UPS Battery Cabinet, which contains batteries having sufficient ampere-hour (A·h) capacity to support the UPS and its intended load for the protection time specified.

The UPS Battery Cabinet features sealed, maintenance-free, recombination type batteries. The batteries are maintenance-free because they *do not* require that the electrolyte level or the density of the electrolyte be checked periodically. The UPS Battery Cabinets *do* require that the interior of the assembly, including the exterior surfaces of the individual batteries, be kept clear of all foreign matter including dust. The integrity of the individual battery connections must be verified annually.

The HA32B series UPS Battery Cabinet is explained in Chapter 3.

## 1.5 OPTIONS

Section 1.5.1 through Section 1.5.8 introduce the options available for the HA32A UPS.

### 1.5.1 UPS Auxiliary Cabinet

The HA32C/D/E UPS Auxiliary Cabinet provides the means to incorporate two separate features into the HA3000 series UPS (see Chapter 4). The UPS Auxiliary Cabinet attaches to the right side of the HA32A UPS enclosure.

The UPS Auxiliary Cabinet enclosure will accommodate right-side cable entry when required, which may occur if the UPS is installed in an equipment room with limited space. The UPS Auxiliary Cabinet may include an input isolation transformer, an input harmonic current filter, or both, depending on which features are purchased. The input isolation transformer provides complete electrical isolation between the utility line and the input of the UPS (rectifier/battery charger and battery). It also provides extra protection against electrical noise and ground faults. The input harmonic current filter limits the amount of harmonic current fed back into the input ac power source to less than 10% when the HA32A UPS is operating at full load.

#### NOTE

**Systems with a 600 Vac input require an HA32C-Ex or HA32D-Ex UPS Auxiliary Cabinet or an HA33D-Ex UPS CSA Cabinet with an isolation/step-down transformer to step down the 600 Vac to 208 Vac for use with the HA32Ax UPS.**

### 1.5.2 UPS CSA Cabinet (Canada Only)

The HA33D/F UPS CSA Cabinet provides the means to make the HA3000 UPS compliant with Canadian Standard Association (CSA) requirements. This is done by providing a mechanical contactor that opens in case of a power failure. This prevents the flow of power from the inverter output to the bypass ac input branches in the event of a static switch SCR failure (short circuit). See Chapter 5 for more information on the HA33D/F UPS CSA Cabinet. The UPS CSA Cabinet attaches to the right side of the HA32A UPS enclosure or the right side of the HA32C/D/E UPS Auxiliary Cabinet enclosure.

The UPS CSA Cabinet enclosure will accommodate right-side cable entry when required, which may occur if the UPS is installed in an equipment room with limited space. The UPS CSA Cabinet may also include an input isolation/step-down transformer. The input isolation/step-down transformer is used for systems with a 600 Vac input. The

transformer secondary voltage is 208 Vac. The transformer supplies both the main ac input (MAINS1), and through the mechanical contactor, the bypass ac input (MAINS2). The transformer also provides complete electrical isolation between the utility line and the input of the UPS (rectifier/battery charger and battery). It also provides extra protection against electrical noise and ground faults.

#### NOTE

**Systems with a 600 Vac input require an HA32C-Ex or HA32D-Ex UPS Auxiliary Cabinet, or an HA33D-Ex UPS CSA Cabinet with an isolation/step-down transformer to step down the 600 Vac to 208 Vac for use with the HA32Ax UPS.**

### 1.5.3 UPS Distribution Cabinet

The HA32J/K UPS Distribution Cabinet provides the means for distributing power from the HA32A UPS system to the user's intended equipment (see Chapter 6). The UPS Distribution Cabinet is furnished in an enclosure matching the other HA3000 series UPS equipment. The UPS Distribution Cabinet attaches to the right side of the HA32A UPS enclosure, the right side of the UPS Auxiliary Cabinet, or the right side of the UPS CSA Cabinet.

### 1.5.4 Remote Status Panel

The Remote Status Panel option may be deskmounted or wallmounted, and uses the same SS&CP as the HA32A UPS (see Figure 1-4). The Remote Status Panel includes the mimic panel to indicate the flow of power; an LCD for display of status, alarms, and parameters measured; and keys for requesting voltage and current data. An interface cable between the Remote Status Panel and the HA32A UPS is included. The HA320-AA model has a 150-foot cable, and the HA320-AB model has a 300-foot cable.

### 1.5.5 Remote Alarm Panel

The HA320-A3 Remote Alarm Panel consists of a wallmounted panel with four indicating LEDs:

- A green UPS On Line LED
- A yellow Load On Bypass LED
- A yellow UPS On Battery LED
- A red Summary Alarm LED

The Remote Alarm Panel also includes:

- An Alarm Reset push button, to reset the latching alarm
- An Audible Alarm (horn), for alarm annunciation
- An Audio Reset push button, to reset the Audible Alarm

When an alarm occurs, the appropriate LED will stay on (latch) even if the alarm is corrected. This feature allows the operator to verify the occurrence of the alarm. Once the alarm has been corrected, the operator can silence the Audible Alarm by pressing the Audio Reset push button, and can reset the latching LEDs by pressing the Alarm Reset push button.

### **1.5.6 DC Ground Fault Detector**

The HA320-C2 DC Ground Fault Detector is used to detect current flowing from the battery terminals to ground. When a dc ground fault is detected, The UPS main ac input (MAINS1) circuit breaker (Q1) trips, shutting off the rectifier/battery charger, and initiates On Battery operation, which prevents any cascading failures. This fault is indicated by an "ENVIRONMENTAL FAULT" message on the UPS LCD display. The DC Ground Fault Detector is located inside the UPS Battery Cabinet.

### **1.5.7 Smoke Detector**

The HA320-B1 Smoke Detector is used to detect the presence of smoke within the UPS Battery Cabinet. When smoke is detected inside the UPS Battery Cabinet, an "ENVIRONMENTAL FAULT" message is displayed on the UPS LED display. The Smoke Detector is located inside the UPS Battery Cabinet.

### **1.5.8 Remote Emergency Power Off (REPO)**

The Remote Emergency Power Off (REPO) option is a wallmounted push button. The REPO feature performs the same function as the EPO (see Section 2.2) but from a remote location.



## HA32A UPS OPERATION

### 2.1 GENERAL

This chapter describes the HA32A system status and control panel (SS&CP), including programmable controls, electromechanical controls, the UPS monitor and available menus, operating modes, and alarm conditions.

### 2.2 SYSTEM STATUS AND CONTROL PANEL (SS&CP)

The SS&CP is located on the upper right portion of the HA32A UPS enclosure. The SS&CP is shown in Figure 2-1, and its elements are described in the following text.

#### NOTE

**When pressed, all of the keys on the SS&CP emit a short tone to indicate to the user that a key has been pressed.**

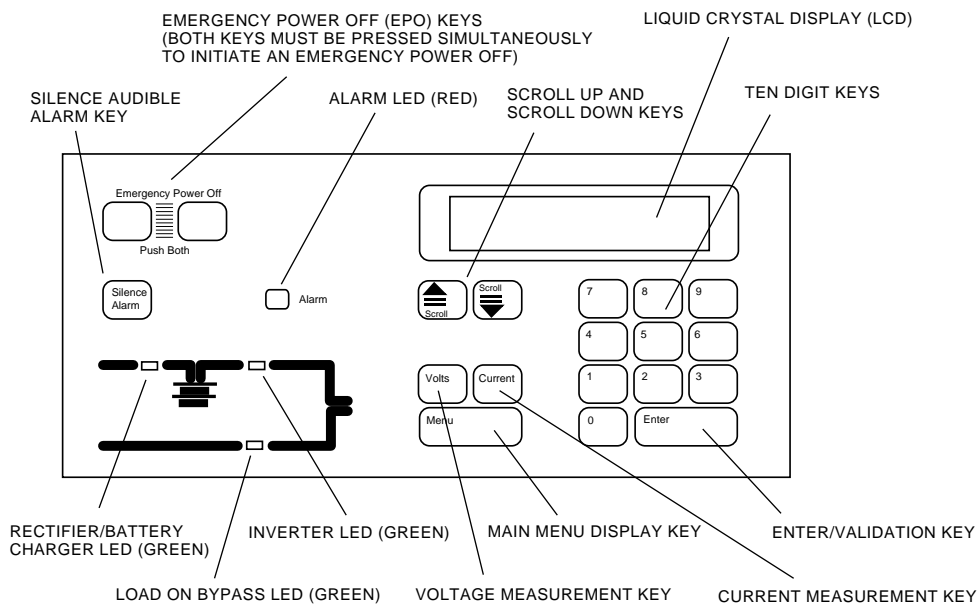

MKV-A2059-91

Figure 2-1 System Status and Control Panel (SS&CP)

### **Liquid-Crystal Display (LCD)**

The liquid-crystal display (LCD) consists of two lines, 20 characters per line. It is used to display measurements, startup and operating procedures, diagnostics, and alarm messages. The LCD contrast can be adjusted to suit the viewing environment by accessing the DISPLAY CONTRAST Menu (Section 2.4.3).

### **Silence Alarm Key**

The Silence Alarm key is used to silence the audible alarm.

### **Scroll Up/Down Keys**

The Scroll Up/Down keys allow the operator to scroll up or down menus on the LCD. When arrows appear on the left side of the LCD, additional text is available that can be viewed by pressing either the Scroll Up or Scroll Down key.

### **Ten Digit (0 to 9) Keys**

These ten digit keys are used to select menus, select items from menus, and to enter or change system settings. When the LCD prompt indicates that a number is to be entered, press the appropriate number key. The number appears on the right side of the LCD. All entries can be modified by re-entering the numbers as long as they have not been validated by pressing the Enter key. If the number has been validated by pressing the Enter key, then the operational sequence must be repeated to change the number.

**Volts Key**



The Volts key is used to display submenus that can be used to monitor:

- Main ac input voltage (MAINS1)—Phase 1 to 2, 2 to 3, and 3 to 1 input voltages
- UPS inverter voltage (UPS output)—Phase 1 to 2, 2 to 3, and 3 to 1 output voltages plus the inverter output frequency
- DC bus voltage (battery)—Battery voltage
- Bypass ac input voltage (MAINS2)—Phase 1 to 2, 2 to 3, and 3 to 1 input voltages plus the input voltage frequency

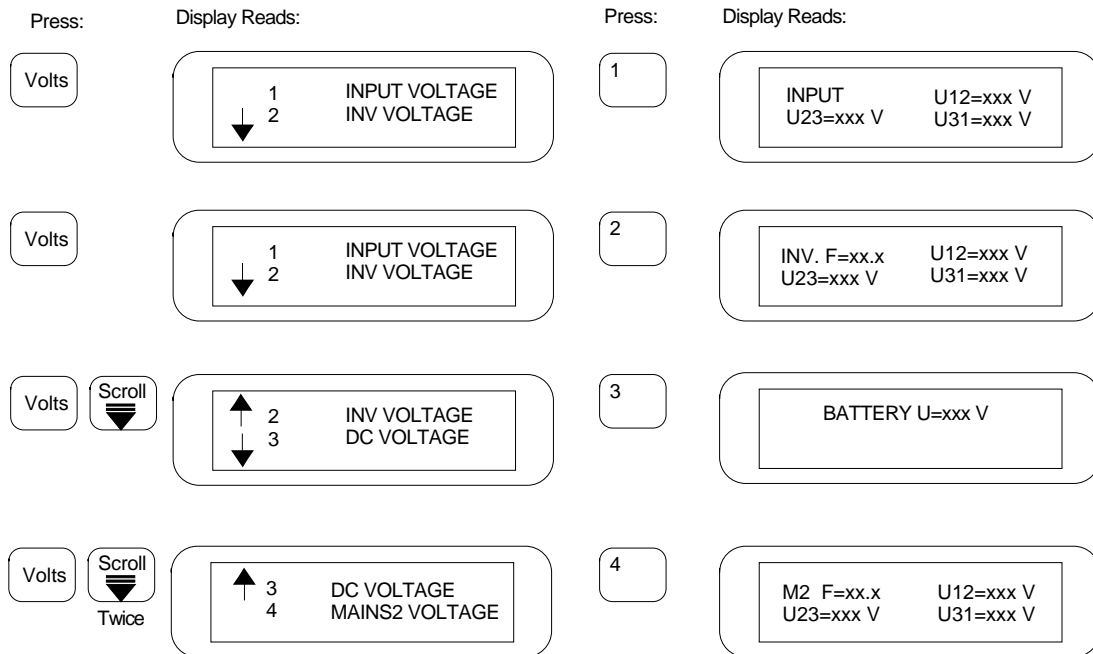
Figure 2-2 shows how to access the submenus and what data is displayed for each.

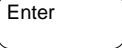

**NOTES:**

1. The desired menu must appear on the LCD before it can be selected for access.
2. Use the  and  keys for menu review.
3. By pressing the  key once, you will return to the place in the previous menu where you exited.

MKV-R5027-91

**Figure 2-2 Voltage Measurements**

### Current Key

The Current key is used to display submenus that can be used to monitor:

- Main ac input current (MAINS1)—Phase 1, 2, and 3 input currents
- UPS inverter current (UPS output)—Phase 1, 2, and 3 output currents plus the % load for the most heavily loaded phase
- Battery current—Negative current (-) indicates battery discharging; positive current (+) indicates battery charging
- Bypass ac input current (MAINS2)—Phase 1, 2, and 3 input currents plus the % load for the most heavily loaded phase

Figure 2-3 shows how to access the submenus and what data is displayed for each.

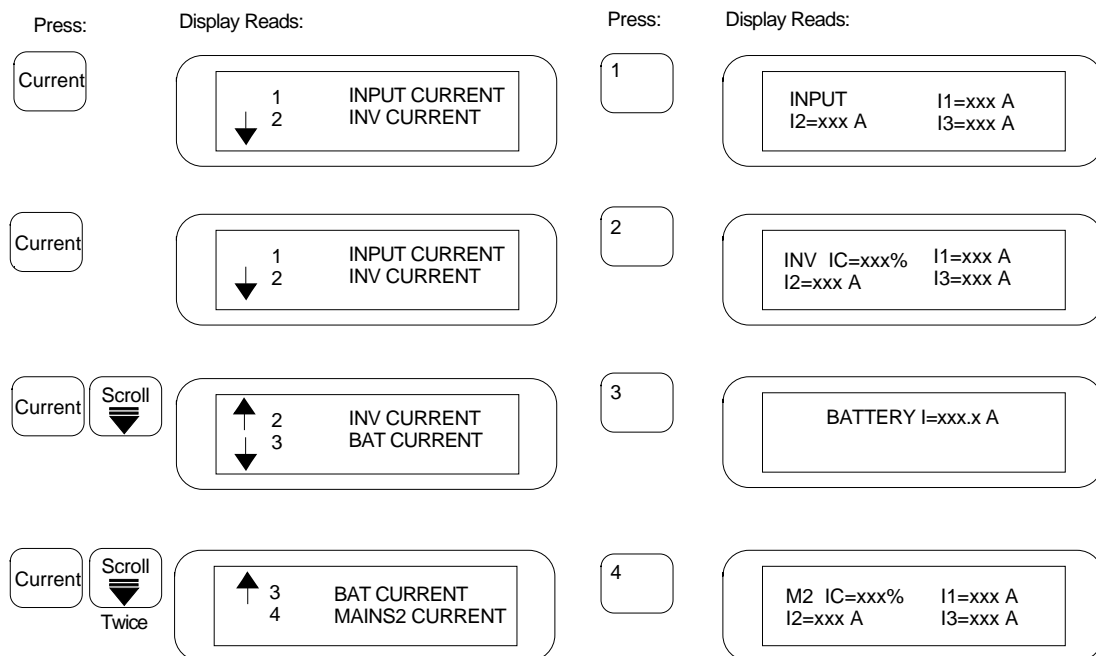

NOTES:

1. The desired menu must appear on the LCD before it can be selected for access.

2. Use the and keys for menu review.

3. By pressing the key once, you will

return to the place in the previous menu where you exited.

MKV-R5028-91

Figure 2-3 Current Measurements



### Menu Key

The Menu key is used to return the operator to the Main Menu display. If an error is made while working with the HA32A UPS, pressing the Menu key twice always returns the operator to the Main Menu.

### Enter Key

The Enter key is used to validate an entry or to return to the exited place in the previous menu.

### Emergency Power Off (EPO) Keys

The two EPO keys must be pressed simultaneously to initiate an EPO shutdown. When an EPO shutdown is initiated, the main ac input (MAINS1) circuit breaker (Q1) is opened, the bypass ac input (MAINS2) switch (Q4S) is turned off, the battery circuit breaker (QF1) located in the UPS Battery Cabinet is opened, and the load power is disconnected.

These keys should only be used for emergency situations. **DO NOT** use these keys for a normal shutdown sequence.

### WARNING

**If the HA32A UPS is in manual or maintenance bypass, the EPO keys will not remove the load power. In these situations, the load power can only be removed by locating and removing the input power source(s).**

### INDICATORS

There are four LED indicators on the SS&CP that are used to monitor the status of the HA32A UPS. The LED indicators and their functions are given below.

### WARNING

**These LEDs are mode indicators and do not indicate the absence or presence of voltage.**

**Alarm LED (Red)** - The red Alarm LED flashes to indicate that a major or minor alarm condition has occurred. The condition that caused the alarm is shown on the LCD. The Scroll Up and Scroll Down keys are used to review all alarm conditions.

**Rectifier/Battery Charger LED (Green)** - The green "rectifier/battery charger" LED is lit when the rectifier/battery charger is operating.

**Inverter LED (Green)** - The green "inverter" LED is lit when the inverter is supplying power to the load.

**Load On Bypass LED (Green)** - The green "load on bypass" LED is lit when the bypass ac input (MAINS2) source is supplying power to the load.

## 2.3 CONTROLS

There are two types of controls for the HA32A UPS: electromechanical and programmable.

### 2.3.1 Electromechanical Controls

The circuit designator for the five electromechanical controls of the HA32A UPS, and the function of each, are listed below. See Figure 2-4 for the location of these controls.

<b>Circuit Designator</b>	<b>Function</b>
Q1	Main ac input (MAINS1) circuit breaker. Applies input voltage to the rectifier/battery charger and provides input current protection.
Q3BP	Manual bypass nonautomatic switch. Allows the bypass ac input to bypass the UPS and is used in conjunction with Q4S and Q5N.
Q4S	Bypass ac input (MAINS2) ON/OFF switch. Applies power to or isolates the static switch. Used in conjunction with Q3BP and Q5N.
Q5N	UPS output isolation switch. Isolates the UPS output and is used in conjunction with Q4S and Q3BP.
K3N	Inverter output contactor. Mechanically isolates the UPS inverter from the static switch. When the static switch is ON, K3N is open. When the static switch is OFF, K3N is closed. This contactor makes a loud mechanical sound when it changes position.

### 2.3.2 Programmable Controls

The programmable controls are covered in detail in Section 2.4 and include such control functions as:

- Rectifier/battery charger start and stop
- Inverter start and stop
- Clearing faults
- Synchronized/nonsynchronized UPS inverter operation
- Output ac voltage adjustment
- DC voltage and battery charger current limit adjustments
- Boost or equalization charge on battery
- Selecting display language
- Diagnostic and test routines
- Adjusting display contrast

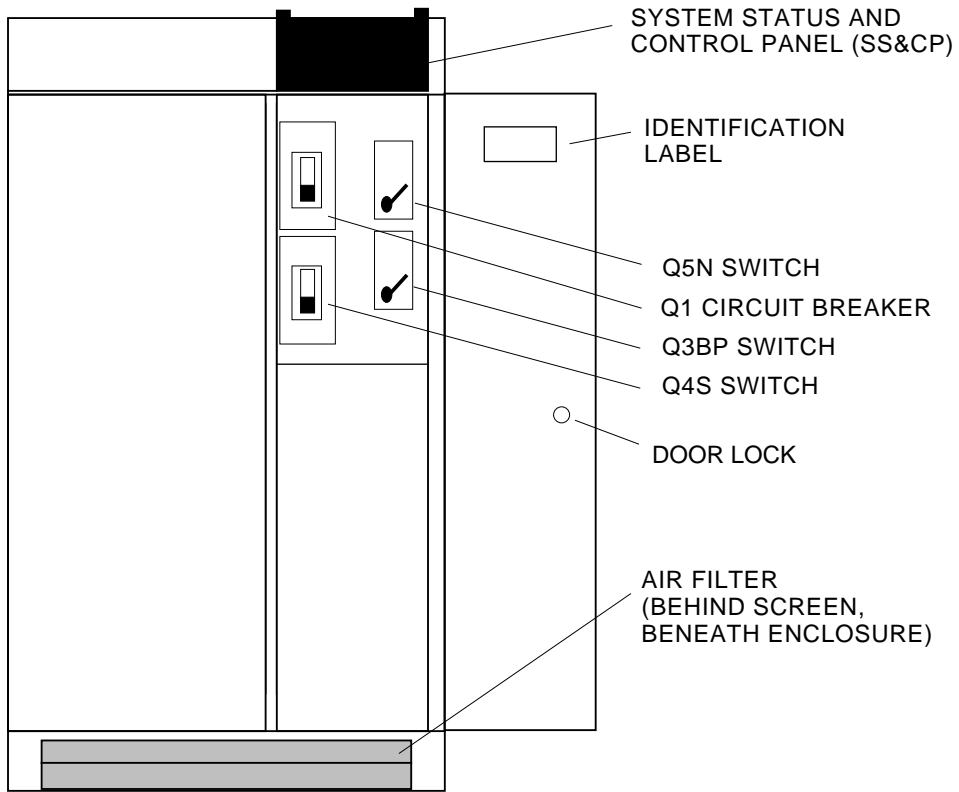

MKV-A2056-91

Figure 2-4 HA32A UPS

## 2.4 UPS MONITOR AND MENUS

The UPS monitor is a firmware package that allows the operator to interact with the HA32A UPS. The UPS monitor is menu driven to perform a function. The operator chooses the appropriate menu and then selects the desired function from the menu.

### NOTE

**If a UPS Auxiliary Cabinet with an input isolation transformer is installed, circuit breaker CB1 on the UPS Auxiliary Cabinet must be turned on before the UPS can be powered up.**

When the HA32A UPS is powered up, the following language selection screens scroll vertically on the LCD until one language is selected.

```
1 ENGLISH
2 FRANCAIS

2 FRANCAIS
3 DEUTSCH

3 DEUTSCH
4 ESPANOL

4 ESPANOL
5 ITALIANO
```

To select a language, press the number key that corresponds to the language desired (press the 1 key to select English). The desired language does not need to be shown on the LCD to make the selection, nor does the Enter key need to be pressed to validate the entry.

After the language selection is made, the LCD displays the following:

```
* * CHECKING * *
* * * * *
```

After a few seconds, the LCD automatically displays the following during startup:

```
↓ TEST POSITION
```

The UPS monitor consists of the nine menus that are listed below and described in the following sections.

- Menu 1 - START-UP
- Menu 2 - INVERTER ON/OFF
- Menu 3 - DISPLAY CONTRAST
- Menu 4 - BATT TRANS. TEST
- Menu 5 - BYPASS PROCEDURE
- Menu 6 - COMMANDS
- Menu 7 - DIAGNOSIS
- Menu 8 - PERSONALIZATION
- Menu 9 - COMMUNICATION

When the Menu key is pressed the first two menu items are displayed on the LCD. The Scroll Up and Scroll Down keys can be used to manually scroll through the available menus. To select a menu, press the number key that corresponds to the desired menu number (for example; press the 1 key for the START-UP menu) only when the desired menu is displayed on the LCD.

Use the following procedure to display and scroll through the available menu items.

1. Press the Menu key and the LCD displays the following:

```

      1   START-UP
      ↓ 2   INVERTER ON/OFF
  
```

2. Press the Scroll Down key twice and the LCD displays the following:

```

      ↑ 3   DISPLAY CONTRAST
      ↓ 4   BATT TRANS. TEST
  
```

3. Press the Scroll Down key twice more and the LCD displays the following:

```

      ↑ 5   BYPASS PROCEDURE
      ↓ 6   COMMANDS
  
```

4. Press the Scroll Down key twice more and the LCD displays the following:

```

      ↑ 7   DIAGNOSIS
      ↓ 8   PERSONALIZATION
  
```

5. Press the Scroll Down key once more and the LCD displays the following:

```

      ↑ 8   PERSONALIZATION
      9   COMMUNICATION
  
```

### 2.4.1 START-UP Menu

The START-UP menu is used to return the HA32A UPS to normal operation after it has been completely powered down.

The following procedure is for accessing and stepping through the START-UP menu.

1. Press the Menu key and the LCD displays the following:

```

      1   START-UP
      ↓ 2   INVERTER ON/OFF
  
```

2. Press the 1 key to select menu item number one, START-UP, and the LCD displays the following:

```

CLOSE OUTPUT SWITCH
ITEM: Q5N
  
```

3. Close the output isolation switch Q5N and the LCD displays the following:

```

CLOSE MAINS2 SWITCH
ITEM: Q4S
  
```

4. Close the bypass ac input (MAINS2) switch Q4S. The green "load on bypass" LED goes on and the LCD displays the following:

```

START THE CHARGER
1 = START _____
  
```

5. To start the rectifier/battery charger press the 1 key and then the Enter key. The following three screens are displayed on the LCD and the green "rectifier/battery charger" LED goes on when the third screen is displayed.

```

RESET FAULTS
  
```

```

* * CHECKING * *
* * * * *
  
```

```

COMMAND ACCEPTED
  
```

6. After the command to start the charger is accepted and the green "rectifier/battery charger" LED goes on, the LCD displays the following:

```

CLOSE BAT. BREAKER
ITEM: QF1
  
```

7. Close the battery circuit breaker QF1 located inside the UPS Battery Cabinet right door. The audible alarm sounds once every three seconds and the LCD displays the following:

```

START THE INVERTER
1 = START _____
  
```

8. To start the inverter press the 1 key and then the Enter key. The following five screens are displayed on the LCD:

RESET FAULTS

\* \* CHECKING \* \*  
\* \* \* \* \*

COMMAND ACCEPTED

END OF PROCEDURE

1     START-UP  
↓ 2     INVERTER ON/OFF

9. After the command to start the inverter is accepted, the inverter starts, the green "inverter" LED goes on, the green "load on bypass" LED goes off, the audible alarm silences, and the flashing red Alarm LED goes off.
10. Press the Enter key and the LCD displays the following screen to indicate that the HA32A UPS has been returned to its normal operating condition.

NORMAL OPERATION  
LOAD ON UPS

## 2.4.2 INVERTER ON/OFF Menu

The INVERTER ON/OFF menu is used to stop the inverter and force the static switch to transfer the load to the bypass ac input (MAINS2) power source, or to start the inverter and return the UPS from bypass to normal operation.

The following procedure is for accessing and going through the INVERTER ON/OFF menu.

1. Press the Menu key and the LCD displays the following:

```

1   START-UP
↓ 2   INVERTER ON/OFF

```

2. Press the 2 key to select menu item number two, INVERTER ON/OFF, and the LCD displays the following:

```

INVERTER
0=STOP  1=START  ____

```

3. To start the inverter, press the 1 key and then the Enter key. The following three screens are displayed on the LCD and the green "inverter" LED goes on when the second screen is displayed.

```

* * CHECKING * *
* * * * *

```

```

COMMAND ACCEPTED

```

```

INVERTER
0=STOP  1=START  ____

```

If the inverter is commanded to start with the rectifier/battery charger off, the LCD will display the following message and the rectifier/battery charger must be started (see Section 2.4.6) before the inverter can be started.

```

COMMAND REJECTED
CHARGER OFF

```

4. To stop the inverter, press the 0 key and then the Enter key. The following three screens are displayed on the LCD. The green "inverter" LED goes off and the green "load on bypass" LED goes on when the second screen is displayed.

```

* * CHECKING * *
* * * * *

```

```

COMMAND ACCEPTED

```

```

INVERTER
0=STOP  1=START  ____

```



If the inverter is commanded to stop during nonsynchronous operation, the LCD will display the following screens and the inverter must be forced off (see Section 2.4.6). The static switch is inhibited during nonsynchronous operation. When the inverter is forced off, the load will transfer to the bypass ac input (MAINS2) with a 200 to 800 millisecond break.

```
MAINS2 OUT OF SPEC  
INV STOP INHIBITED
```

```
INV FORCED STOP  
0=NO    1=YES    _____
```

5. Press the Enter key to return to the menu display.

### 2.4.3 DISPLAY CONTRAST Menu

The DISPLAY CONTRAST menu allows the operator to adjust the contrast of the LCD so that it can be easily read under different room lighting conditions.

The following procedure is for accessing and going through the DISPLAY CONTRAST menu.

1. Press the Menu key and the LCD displays the following:

```
  1  START-UP  
↓ 2  INVERTER ON/OFF
```

2. Press the Scroll Down key twice and the LCD displays the following:

```
↑ 3  DISPLAY CONTRAST  
↓ 4  BATT TRANS. TEST
```

3. Press the 3 key to select menu item number three, DISPLAY CONTRAST, and the LCD displays the following:

```
↑ -  CONTRAST  
↓ +
```

4. Press the Scroll Up key to decrease the contrast (lighten the LCD) or the Scroll Down key to increase the contrast (darken the LCD).
5. Press the Enter key to return to the menu display.

## 2.4.4 BATT TRANS. TEST Menu

The BATT TRANS. TEST menu allows the operator to simulate an input power failure by turning off the rectifier/battery charger and allowing the inverter to operate from battery power for two minutes, then returning the UPS to normal operation. This test should be performed periodically to ensure proper UPS operation.

This test is only possible if the battery has been charged for at least 10 hours. The bypass ac input (MAINS2) source frequency and voltage must also be within the prescribed limits for a no-break transfer to the bypass ac input (MAINS2) source in case of a battery problem.

After running this test, some period of time is required to recharge the batteries to their full rated capacity.

If this test is attempted and the battery has been discharged within the last 10 hours, the following message will be displayed on the LCD:

```
BATTERY RECHARGE
MINI AUTO = X MN
```

The following procedure is for accessing and going through the BATT TRANS. TEST menu.

1. Press the Menu key and the LCD displays the following:

```
1   START-UP
↓ 2   INVERTER ON/OFF
```

2. Press the Scroll Down key twice and the LCD displays the following:

```
↑ 3   DISPLAY CONTRAST
↓ 4   BATT TRANS. TEST
```

3. Press the 4 key to select menu item number four, BATT TRANS. TEST, and the LCD displays the following:

```
STOP THE CHARGER
0 = STOP _____
```

4. Press the 0 key and then the Enter key. The LCD displays the following screens:

```
* * CHECKING * *
* * * * *
```

```
COMMAND ACCEPTED
```

```
BATTERY TEST
AUTO=XX MN   Ub=XXX V
```

5. When the command to stop the rectifier/battery charger is accepted, the green "rectifier/battery charger" LED goes off and the time remaining on battery operation and the battery voltage are displayed on the LCD.

6. When the test has completed successfully the LCD displays the following:

BATTERY OK

RESET FAULTS

COMMAND ACCEPTED

\* \* CHECKING \* \*  
\* \* \* \* \*

↑ 3      DISPLAY CONTRAST  
↓ 4      BATT TRANS. TEST

## 2.4.5 BYPASS PROCEDURE Menu

The BYPASS PROCEDURE menu is used to manually transfer the load to the bypass ac input (MAINS2) source without interruption to the load, and for the reverse transfer of the load back to the UPS inverter output.

If the bypass ac input (MAINS2) source is out of tolerance, these transfers will result in a 200 to 800 millisecond load interruption and can be performed only with a FORCED STOP command (see Section 2.4.6.4). The FORCED STOP command can be issued only after entering the two-digit password.

The following procedure is for accessing and going through the BYPASS PROCEDURE menu.

1. Press the Menu key and the LCD displays the following:

```

1   START-UP
↓ 2   INVERTER ON/OFF

```

2. Press the Scroll Down key four times and the LCD displays the following:

```

↑ 5   BYPASS PROCEDURE
↓ 6   COMMANDS

```

3. Press the 5 key to select menu item number five, BYPASS PROCEDURE, and the LCD displays the following:

```

1   SW TO MAN BY-PASS
2   RETURN TO UPS

```

### To Transfer To Manual Bypass

4. To transfer to manual bypass, press the 1 key and the LCD displays the following:

```

STOP THE INVERTER
0 = STOP _____

```

5. Press the 0 key and then the Enter key. The LCD displays the following screens:

```

* * CHECKING * *
* * * * *

```

```

COMMAND ACCEPTED

```

```

CLOSE BY-PASS SW
ITEM: Q3BP

```

6. When the command to stop the inverter is accepted, the inverter turns off, the green "inverter" LED goes off, the green "load on bypass" LED goes on, the audible alarm activates, and the red Alarm LED flashes.
7. Close the manual bypass switch Q3BP. The LCD displays the following:

```

OPEN MAINS2 SWITCH
ITEM: Q4S

```

8. Open the bypass ac input (MAINS2) switch Q4S. The green "load on bypass" LED goes off and the LCD displays the following:

OPEN OUTPUT SWITCH  
ITEM: Q5N

9. Open the output isolation switch Q5N. The LCD displays the following:

END OF PROCEDURE

1 SW TO MAN BY-PASS  
2 RETURN TO UPS

### **WARNING**

**Manual bypass is not intended for maintenance procedures. Contact Digital Services for maintenance procedures.**

### **To Return To Inverter**

1. To return the UPS to normal (inverter) operation, press the 2 key and the LCD displays the following:

CLOSE OUTPUT SWITCH  
ITEM: Q5N

2. Close the output isolation switch Q5N. The LCD displays the following:

CLOSE MAINS2 SWITCH  
ITEM: Q4S

3. Close the bypass ac input (MAINS2) switch Q4S. The green "load on bypass" LED goes on and the LCD displays the following:

OPEN BY-PASS SWITCH  
ITEM: Q3BP

4. Open the manual bypass switch Q3BP. The audible alarm activates and the LCD displays the following:

START INVERTER  
1 = START \_\_\_\_\_

5. Press the 1 key and then the Enter key. The LCD displays the following screens:

```

RESET FAULTS

* * CHECKING * *
* * * * *

COMMAND ACCEPTED

END OF PROCEDURE

1   SW TO MAN BY-PASS
2   RETURN TO UPS

```

6. When the command to start the inverter is accepted, the inverter turns on, the green "inverter" LED goes on, the green "load on bypass" LED goes off, the audible alarm silences, and the red Alarm LED goes off.
7. Press the Enter key and the LCD displays the following:

```

↑ 5   BYPASS PROCEDURE
↓ 6   COMMANDS

```

8. Press the Enter key again and the LCD displays the following screen to indicate that the UPS has returned to normal operation:

```

NORMAL OPERATION
LOAD ON UPS

```

## 2.4.6 COMMANDS Menu

The COMMANDS menu is used to initiate the following operations:

- Rectifier/battery charger start and stop
- Inverter start and stop
- Reset faults stored in memory
- Synchronous/nonsynchronous UPS inverter operation
- Boost charging of the battery
- Equalization charging of the battery
- Selection of the display language

After accessing the COMMANDS menu, use the Scroll Up and Scroll Down keys to select the desired command. While the selected command is being executed, the LCD displays the following two screens:

```
* * CHECKING * *
* * * * *
```

```
COMMAND ACCEPTED
```

The following procedure is for accessing and going through the COMMANDS menu.

1. Press the Menu key and the LCD displays the following:

```
  1  START-UP
↓ 2  INVERTER ON/OFF
```

2. Press the Scroll Down key four times and the LCD displays the following:

```
↑ 5  BYPASS PROCEDURE
↓ 6  COMMANDS
```

3. Press the 6 key to select menu item number six, COMMANDS, and the LCD displays the first available command operation.

### 2.4.6.1 Rectifier/Battery Charger Start and Stop

Use the following procedure to access the rectifier/battery charger start and stop command.

1. When the COMMANDS menu is accessed by pressing the 6 key, the first command available is the rectifier/battery charger start and stop command, and the LCD displays the following:

```
CHARGER
↓ 0=STOP 1=START ____
```

2. To start the rectifier/battery charger, press the 1 key and then the Enter key. To stop the rectifier/battery charger, press the 0 key and then the Enter key.



#### 2.4.6.2 Inverter Start and Stop

Use the following procedure to access the inverter start and stop command.

1. After accessing the COMMANDS menu, press the Scroll Down key until the LCD displays the following:

```

↑  INVERTER
↓  0=STOP  1=START  ____

```

2. To start the inverter, press the 1 key and then the Enter key. To stop the inverter, press the 0 key and then the Enter key.

#### 2.4.6.3 Resetting Faults Stored in Memory

Use the following procedure to access the resetting faults stored in memory command.

1. After accessing the COMMANDS menu, press the Scroll Down key until the LCD displays the following:

```

↑  RESET FAULTS
↓  1=YES      ____

```

2. To reset faults stored in memory, press the 1 key and then the Enter key.

#### 2.4.6.4 Synchronous/Nonsynchronous Operation

Synchronizing and desynchronizing the inverter requires the entry of a two-digit password. If an error is made when entering the password, the UPS monitor will allow the password to be re-entered.

#### NOTE

**The two-digit password will not appear on the LCD.**

#### CAUTION

**The !LOAD INTERRUPT! message indicates that the load power will be interrupted for a minimum of 200 milliseconds. Be certain that the load can tolerate this interruption.**

#### NOTE

**When the UPS inverter is operated in nonsynchronous mode in relation to the bypass ac input (MAINS2) source, operation of the static switch is inhibited.**

Use the following procedure to access the synchronous/nonsynchronous operation command.

1. After accessing the COMMANDS menu, press the Scroll Down key until the LCD displays the following:

```

↑ MAINS2 UNSYNCHRON.
↓ PASSWORD?  _ _

```

2. Enter the password by pressing the 1 key, the 9 key, and then the Enter key. The LCD displays the following:

```

MAINS2 UNSYNCHRON.
0=NO 1=YES      ____

```

3. For synchronous operation, press the 0 key and then the Enter key. For nonsynchronous operation, press the 1 key and then the Enter key.
4. After the Unsync Decision screen appears, the LCD displays the following:

```

↑ MAINS2 UNSYNCHRON.
↓ PASSWORD?  _ _

```

#### 2.4.6.5 Battery Boost Charge

(Not an operator selectable command)

Use the following procedure to access the boost charging of the battery command.

1. After accessing the COMMANDS menu, press the Scroll Down key until the LCD displays the following:

```

↑ BAT BOOSTING
↓ 1=YES      ____

```

2. To apply boost charge voltage to the battery, press the 1 key and then the Enter key.

#### 2.4.6.6 Battery Equalization Charge

(Not an operator selectable operation)

Use the following procedure to access the equalization charging of the battery command.

1. After accessing the COMMANDS menu, press the Scroll Down key until the LCD displays the following:

```

↑ BATT. EQUALIZATION
↓ 0=NO 1=YES      ____

```

2. To continue without applying an equalization charge voltage to the battery, press the 0 key and then the Enter key.

- To apply an equalization charge voltage to the battery, press the 1 key and then the Enter key. Since the inverter must be shut down to apply an equalization charge voltage to the battery, the LCD displays the following.

```

STOP THE INVERTER
0=STOP      ____

```

- Press the 0 key and then the Enter key. The inverter stops and equalization charging of the battery begins.

#### 2.4.6.7 Language Selection

Use the following procedure to access the language selection command.

- After accessing the COMMANDS menu, press the Scroll Down key until the LCD displays the following:

```

↑ LANGUAGE?
↓ 1=ENGLISH ____

```

- To select English as the display language, press the 1 key and then the Enter key. If English is not the desired language, press the Scroll Down key and the LCD displays the following:

```

↑ LANGUAGE?
↓ 2=FRANCAIS ____

```

- To select French as the display language, press the 2 key and then the Enter key. If French is not the desired language, press the Scroll Down key and the LCD displays the following:

```

↑ LANGUAGE?
↓ 3=DEUTSCH ____

```

- To select German as the display language, press the 3 key and then the Enter key. If German is not the desired language, press the Scroll Down key and the LCD displays the following:

```

↑ LANGUAGE?
↓ 4=ESPANOL ____

```

- To select Spanish as the display language, press the 4 key and then the Enter key. If Spanish is not the desired language, press the Scroll Down key and the LCD displays the following:

```

↑ LANGUAGE?
↓ 5=ITALIANO ____

```

- To select Italian as the display language, press the 5 key and then the Enter key.

### 2.4.7 DIAGNOSIS Menu

The DIAGNOSIS menu is used to initiate the standard self-test routine that is built into the UPS.

The following procedure is for accessing and going through the DIAGNOSIS menu.

1. Press the Menu key and the LCD displays the following:

```

      1   START-UP
      ↓ 2   INVERTER ON/OFF
  
```

2. Press the Scroll Down key six times and the LCD displays the following:

```

      ↑ 7   DIAGNOSIS
      ↓ 8   PERSONALIZATION
  
```

3. Press the 7 key to select menu item number seven, DIAGNOSIS, and the LCD displays the following:

```

STOP THE INVERTER
FOR SELF-TEST
  
```

```

STOP THE INVERTER
0 = STOP      _____
  
```

4. Press the 0 key and then the Enter key. The LCD displays the following screens:

```

* * CHECKING * *
* * * * *
  
```

```

COMMAND ACCEPTED
  
```

5. When the command to stop the inverter is accepted, the inverter turns off, the green "inverter" LED goes off, the green "load on bypass" LED goes on, the audible alarm activates, the red Alarm LED flashes, and the LCD displays the following screens:

```

STOP THE CHARGER
FOR SELF-TEST
  
```

```

STOP THE CHARGER
0=STOP      _____
  
```

6. Press the 0 key and then the Enter key. The LCD displays the following screens:

```

* * CHECKING * *
* * * * *
  
```

```

COMMAND ACCEPTED
  
```

- When the command to stop the rectifier/battery charger is accepted, the rectifier/battery charger turns off, the green "rectifier/battery charger" LED goes off, and the LCD displays the following:

```
Q1 SWITCH CLOSED?
ITEM: Q1 OK=1  —
```

- If the main ac input (MAINS1) circuit breaker (Q1) is closed, press the 1 key and then the Enter key. The LCD displays the following:

```
Q4S SWITCH CLOSED?
ITEM: Q4S OK=1  —
```

- The five alarms shown in the following three LCD screens are normal alarm conditions that should appear for the present status of the UPS (both the inverter and rectifier/battery charger are off). If any other alarm conditions are displayed, immediate action should be taken. Write down all of the alarms and contact Digital Services for assistance at 1-800-272-2001. Have your access number available.

If the bypass ac input (MAINS2) switch (Q4S) is closed, press the 1 key and then the Enter key. The LCD displays the following:

```
NOTE THE ALARMS
THEN PUSH ON  ←
```

```
↓          ALARMS
          INVERTER OFF
```

- Press the Scroll Down key twice and the LCD displays the following:

```
↑          INVERTER OV OR UV
↓          K3N IS OPEN
```

- Press the Scroll Down key twice more and the LCD displays the following:

```
↑          CHARGER OFF
          INV PHASE OUT TOL
```

- After viewing all of the alarm conditions, press the Enter key. The LCD displays the following screens:

```
* * SELF-TESTING * *
* * * * *
```

```
SELF TEST RESULT:
LOGIC OK  ←
```

13. Press the Enter key and the LCD displays the following screens:

```
ANALOG TEST
PCB AQCX
```

```
ANALOG TEST
PCB AQOX
```

```
START THE CHARGER
1=START _____
```

14. Press the 1 key and then the Enter key to start the rectifier/battery charger. The LCD displays the following screens:

```
RESET FAULTS
```

```
* * CHECKING * *
* * * * *
```

```
COMMAND ACCEPTED
```

15. When the command to start the rectifier/battery charger is accepted, the rectifier/battery charger turns on, the green "rectifier/battery charger" LED goes on, and the LCD displays the following:

```
START THE INVERTER
1=START _____
```

16. Press the 1 key and then the Enter key to start the inverter. The LCD displays the following screens:

```
RESET FAULTS
```

```
* * CHECKING * *
* * * * *
```

```
COMMAND ACCEPTED
```

17. When the command to start the inverter is accepted, the inverter turns on, the green "inverter" LED goes on, the green "load on bypass" LED goes off, the audible alarm silences, the red Alarm LED goes off, and the LCD displays the following screens:

END OF PROCEDURE

↑ 6    COMMANDS  
↓ 7    DIAGNOSIS

18. Press the Enter key and the LCD displays the following screen to indicate that the UPS has returned to normal operation.

NORMAL OPERATION  
LOAD ON UPS

### **2.4.8 PERSONALIZATION Menu**

The PERSONALIZATION menu allows access to routines that tailor the operation of the UPS to the specific installation. This menu should be accessed by an authorized Digital Services representative.

### **2.4.9 COMMUNICATION Menu**

The COMMUNICATION menu is used to enter the RS-232 interface parameters when required, and should be accessed only by an authorized Digital Services representative.

The RS-232 port was designed for use with Digital's Remote Environmental Monitoring Software (REMS). Contact a Digital sales representative for more information on REMS.



## 2.5 OPERATING MODES

The HA32A UPS has both automatic and manual operating modes. These modes of operation are described in more detail in the following sections.

### 2.5.1 Automatic Operating Sequences

The four automatic operating sequences are described in the following sections.

#### 2.5.1.1 Normal Operation

Normal operation is when main ac input (MAINS1) power and bypass ac input (MAINS2) power are available and are within the prescribed tolerances. The critical load is being supplied by the inverter output, which is being supplied by the rectifier/battery charger output. The UPS Battery Cabinet is on float charge condition. The flow of power during normal operation is shown in Figure 2-5.

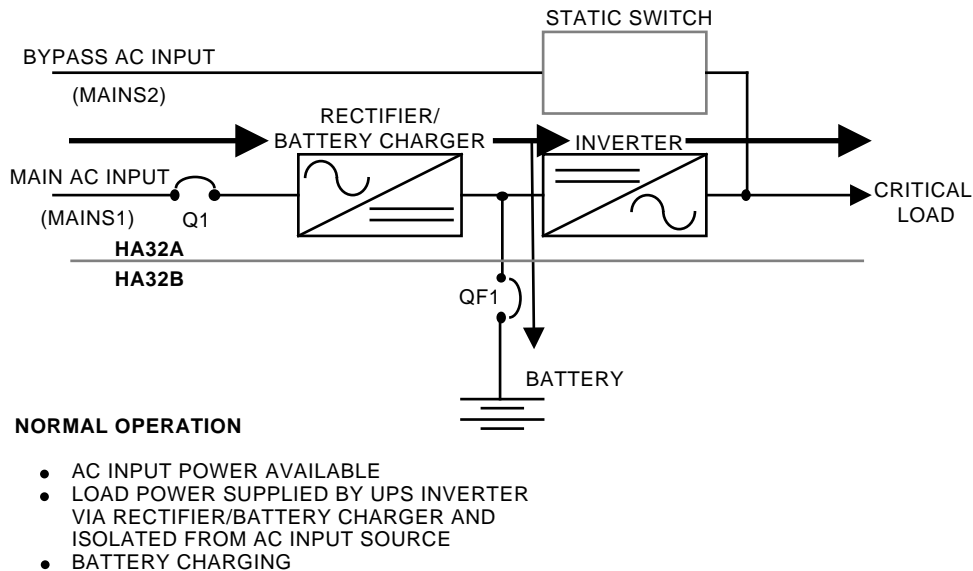

MKV-A2060-91

Figure 2-5 Normal Operation Power Flow

### 2.5.1.2 On Battery Operation

On battery operation occurs when main ac input (MAINS1) power is lost, if the main ac input (MAINS1) power drops more than 15% below nominal value, or if the rectifier/battery charger circuit fails. The flow of power during on battery operation is shown in Figure 2-6.

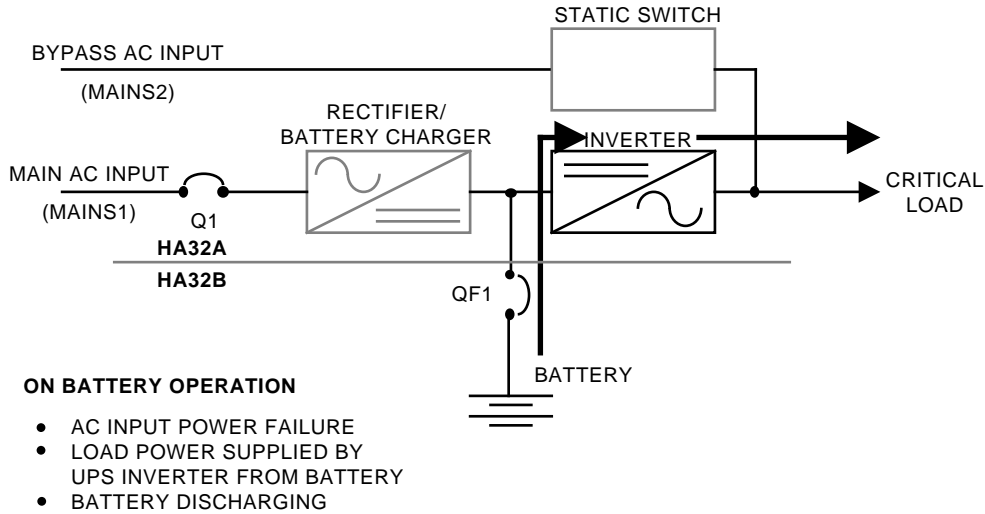

MKV-A2061-91

**Figure 2-6 On Battery Operation Power Flow**

Battery protection time depends on the the ampere-hour capacity of the installed batteries and the power consumed by the load. The specified nominal battery protection time for the installed UPS Battery Cabinet is the minimum duration when operating at 25°C (77°F) with the inverter output under full-rated load (rated kVA @ 0.8 Power Factor lagging). The actual protection time can be greater than the specified protection time if the inverter is operating at less than full load. During a main ac input (MAINS1) power failure, operation on battery power can be extended by reducing the load (noncritical equipment). This can be monitored by using the Volts key and selecting DC VOLTAGE (Figure 2-2).

The battery protection period ends when the battery voltage reaches the inverter cut-off voltage (325 Vdc). When the battery voltage is 10 Vdc above the inverter cutoff voltage, the LCD displays the message:

LOW BATTERY SHUTDOWN

This is a warning that the battery is approaching the end point of discharge and that the protection period has nearly expired.

### 2.5.1.3 Input Power Restored/Battery Charging

As soon as main ac input (MAINS1) power is restored, and the voltage and frequency are within specified tolerances, the UPS returns to normal operation (see Section 2.5.1.1). If the battery reaches its end point of discharge before the main ac input (MAINS1) power is restored, the UPS inverter will shut down and must be manually restarted by following the START-UP menu in Section 2.4.1.

Under normal circumstances the rectifier/battery charger immediately begins recharging the battery. Minimum battery recharge time (yielding 95% capacity) is ten times the discharge time.

#### Example:

A 5 minute discharge time will require 50 minutes of charge time to reach 95% capacity.

Twenty four hours is required for full recharge.

### 2.5.1.4 UPS Inverter Shutdown or Major Overload

In the event of a UPS inverter shutdown (either manually initiated by the user or caused by the UPS internal protective devices), the load is automatically transferred to the bypass ac input (MAINS2) power source without interruption of load power. The power flow for a UPS inverter shutdown or major overload is shown in Figure 2-7.

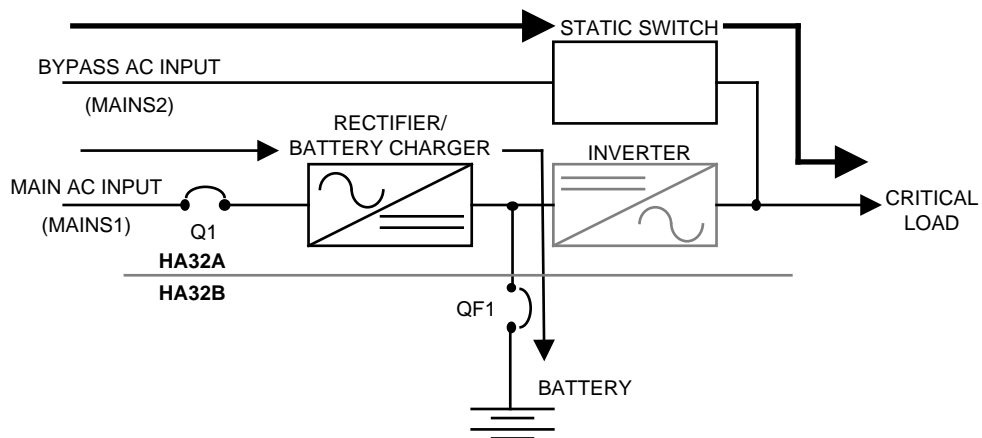

#### UPS INVERTER SHUTDOWN OR MAJOR OVERLOAD

- AC INPUT POWER AVAILABLE (1)
- OVERLOAD POWER SUPPLIED BY BYPASS AS INPUT (MAINS2) SOURCE VIA STATIC SWITCH
- INVERTER OFF
- INVERTER AUTOMATICALLY RESTARTS AS SOON AS OVERLOAD CLEARS
- TRANSFER OF LOAD TO AND FROM BYPASS AC INPUT (MAINS2) SOURCE OCCURS WITHOUT LOSS OF LOAD POWER

#### NOTE:

IN THE EVENT THAT AN OVERLOAD OCCURS WHEN THE BYPASS AC INPUT (MAINS2) SOURCE IS NOT AVAILABLE, THE UPS INVERTER WILL LIMIT THE OUTPUT CURRENT TO ITS 150% CURRENT RATING AT REDUCED VOLTAGE.

MKV-A2062-91

Figure 2-7 UPS Inverter Shutdown or Major Overload Power Flow

In the event of a major overload (inrush condition) on the output of the UPS inverter, an immediate transfer of the load to the bypass ac input (MAINS2) power source takes place. The load is automatically returned to the UPS inverter output without interruption when the inrush condition is over. This operating mode allows startup of load devices demanding short-term, high inrush currents, provided that the UPS inverter is synchronized to the bypass ac input (MAINS2) power source.

The UPS inverter output is synchronized to the bypass ac input (MAINS2) power source when the following conditions are satisfied.

- Bypass voltage must be within  $\pm 10\%$  of nominal value
- Bypass frequency must be within the frequency window selected ( $\pm 0.25$ ,  $\pm 0.5$ ,  $\pm 0.75$ , or  $\pm 1.0$  Hz)
- Bypass phase must be within  $3^\circ$  of the UPS inverter output

#### NOTE

**OUT OF SYNCHRONIZATION messages will be displayed on the LCD as minor alarms.**

If an overload condition occurs and the UPS inverter output is not synchronized to the bypass ac input (MAINS2) power source, the UPS inverter will limit the output current at 150% of its full-load current rating for 0.2 seconds before shutting down and forcing an interrupted transfer of the load to the bypass ac input (MAINS2) power source.

The UPS inverter provides full output voltage at 125% overload for 10 minutes or at 150% overload for 1 minute. If a 125% overload still exists after 10 minutes or a 150% overload still exists after 1 minute, the static switch will transfer the load to the bypass ac input (MAINS2) power source. If the 125% overload still exists after 10 minutes on bypass or the 150% overload still exists after 1 minute on bypass, the static switch will shut off and the load will be dropped.

## 2.5.2 Manual Operating Sequences

The six manual operating sequences are described in the following sections.

### 2.5.2.1 Rectifier/Battery Charger Start or Stop

This sequence is used to stop the rectifier/battery charger to force the UPS to on battery operation, and to start the rectifier/battery charger to return the UPS from on battery operation to normal operation. These operational sequences can be initiated by following the instructions in the Main Menu, item COMMANDS (see Section 2.4.6.1).

### 2.5.2.2 UPS Inverter Start or Stop

This sequence is used to stop the inverter to force the static switch to transfer the load to the bypass ac input (MAINS2) power source, and to start the inverter to return the UPS from bypass to normal operation. These operational sequences can be initiated by following the instructions in the Main Menu, item INVERTER ON/OFF (see Section 2.4.2).

### 2.5.2.3 UPS Manual Bypass

This sequence is used to manually transfer the load to the bypass ac input (MAINS2) power source to bypass the UPS circuits. This sequence should be initiated when problems with the rectifier/battery charger or static switch present the possibility of dropping power to the critical load. This operational sequence can be initiated by following the instructions in the Main Menu, item BYPASS PROCEDURE (see Section 2.4.5). The power flow for the UPS manual bypass is shown in Figure 2-8.

#### WARNINGS

**The EPO keys and the REPO push button will NOT remove output power from the UPS when the UPS is in manual bypass.**

**There are still high voltages present in the HA32A UPS cabinet with the UPS in manual bypass. DO NOT open the left door or remove any covers or protective panels when in manual bypass.**

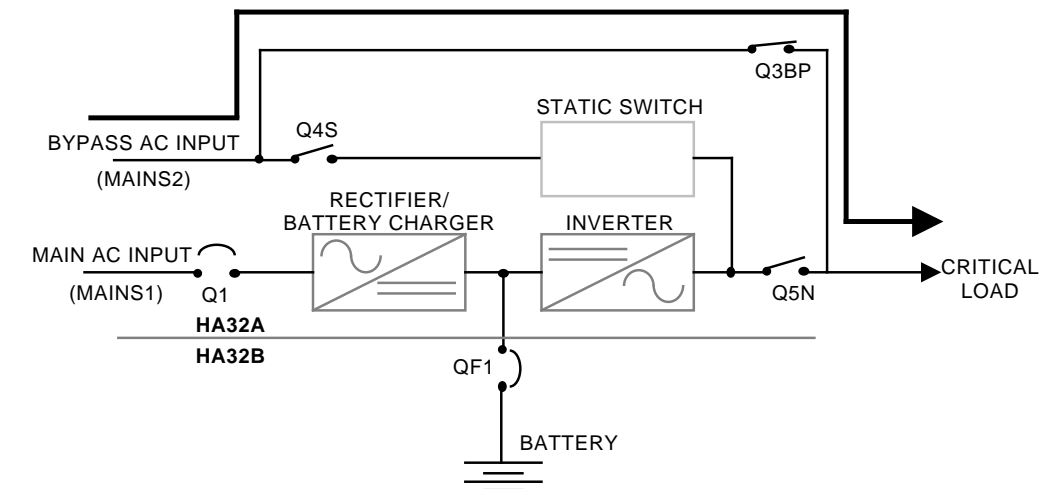

#### UPS MANUAL BYPASS

- AC INPUT POWER AVAILABLE
- LOAD POWER SUPPLIED BY BYPASS AS INPUT (MAINS2) POWER SOURCE

MKV-A2063-91

**Figure 2-8 UPS Manual Bypass Power Flow**

### 2.5.2.4 Returning the UPS to Normal Operation from Manual Bypass

To return to normal operation from manual bypass, press the Menu key and scroll down the menus available with the Scroll Down key until item number 5, BYPASS PROCEDURE, is displayed on the LCD. Press the 5 key and then select submenu number 2, RETURN TO UPS, by pressing the 2 key. Follow the instructions displayed on the LCD to transfer the UPS back on-line.

## 2.6 ALARMS

There are two types of alarms in the HA32A UPS; minor and major alarms. The following sections describe the minor and major alarms and contain tables listing the alarms and what they indicate.

There are no customer serviceable parts in the UPS equipment. For all repairs, call 1-800-272-2001 or your Digital Services office.

### 2.6.1 Minor Alarms

Minor alarms are those that occur during normal operation but do not interfere with the normal operation of the UPS. These alarms should be corrected as soon as possible. Minor alarms are indicated by the audible alarm sounding, the red Alarm LED flashing, and the following screen being displayed on the LCD:

↓                   ALARMS  
LOAD ON UPS

Table 2-1 contains minor alarm messages that could appear on the LCD after pressing the Scroll Down key and what each message indicates.

**Table 2-1 Minor Alarm Messages**

Alarm Message	Problem Indication
MAINS2 RC FU BLOWN	A bypass ac input (MAINS2) surge protector network fuse (F4, F5, or F6) has blown.
UPS FAN FAILURE	One of the two internal fans has failed.
OUTPUT OVERLOAD	One or more of the three output phases is providing more than 100% of the full load current rating of the UPS.
CHARGER CT FAULT	The input current sensing circuit (CT1 or CT2) is not operating correctly.
CHARG MODULE FAULT	A fault has occurred in the rectifier/battery charger module.
MAINS2 OV OR UV	The UPS inverter output is not synchronized to the bypass ac input (MAINS2) source because the bypass ac input voltage is not within $\pm 10\%$ of the nominal value. Operation of the static switch is inhibited.
MAINS2 OF OR UF	The UPS inverter output is not synchronized to the bypass ac input (MAINS2) source because the bypass ac input frequency is not within the selected frequency window (normally $\pm 0.5$ Hz). Operation of the static switch is inhibited.
MAINS2 UNSYNCHRON	The UPS inverter output is not synchronized to the bypass ac input (MAINS2) source because the phase differential between the two is greater than $3^\circ$ . Operation of the static switch is inhibited.

**Table 2-1 (Cont.) Minor Alarm Messages**

<b>Alarm Message</b>	<b>Problem Indication</b>
ENVIRONMENTAL FAULT	<p>This indicates that one of eight problems has occurred in the UPS Battery Cabinet, the UPS Auxiliary Cabinet, the UPS CSA Cabinet, or the UPS Distribution Cabinet:</p> <ol style="list-style-type: none"> <li>1. The Smoke Detector has detected smoke in the UPS Battery Cabinet.</li> <li>2. The DC Ground Fault Detector has detected battery currents flowing to ground in the UPS Battery Cabinet.</li> <li>3. The input circuit breaker CB1 in the UPS Auxiliary Cabinet has tripped.</li> <li>4. The input isolation transformer in the UPS Auxiliary Cabinet has overheated.</li> <li>5. One or more of the input harmonic current filter fuses (F1, F2, and F3) in the UPS Auxiliary Cabinet have blown.</li> <li>6. The isolation/step-down transformer in the UPS Distribution Cabinet has overheated.</li> <li>7. The isolation/step-down transformer in the UPS CSA Cabinet has overheated.</li> <li>8. The input circuit breaker CB1 in the UPS CSA Cabinet has tripped.</li> </ol>

## 2.6.2 Major Alarms

There are two types of major alarms in the HA32A UPS; rectifier/battery charger and inverter alarms. Major alarms are those that prevent normal operation of the UPS by causing the rectifier/battery charger or the inverter to shut down. These alarms should be corrected immediately.

The following sections describe the rectifier/battery charger and inverter major alarms and contain tables listing the alarms and what they indicate.

### 2.6.2.1 Rectifier/Battery Charger Major Alarms

Rectifier/battery charger major alarms occur when the rectifier/battery charger is not operating and load power is being provided by the batteries. These alarms are indicated by the audible alarm sounding, the red Alarm LED flashing, the UPS being on battery operation, and the following screen being displayed on the LCD:

```
INV ON BATTERY
MINI AUTO. = xxxMN
```

Table 2-2 contains the rectifier/battery charger major alarm messages that could appear on the LCD after pressing the Scroll Down key and what each message indicates.

**Table 2-2 Rectifier/Battery Charger Major Alarm Messages**

<b>Alarm Message</b>	<b>Problem Indication</b>
END OF AUTOMY	The battery has reached its end point of discharge and the inverter has turned off.
MAINS1 OV OR UV	The rectifier/battery charger has turned off because of an input ac over/undervoltage condition.
MAX BAT VOLTAGE	The rectifier/battery charger has turned off because of a high dc output voltage condition.
MAINS1 PH SEQ NOK	The rectifier/battery charger will not start because of an incorrect phase rotation sequence on the input.
CHARGER OFF	The rectifier/battery charger has been programmed OFF or turned off automatically.

### 2.6.2.2 Inverter Major Alarms

Inverter major alarms occur when the inverter is not operating and load power is being supplied by the bypass ac input (MAINS2) source after a successful static transfer. These alarms are indicated by the audible alarm sounding, the red Alarm LED flashing, the UPS being on bypass operation, and the following screen being displayed on the LCD:

↓                   ALARMS  
                          INVERTER OFF

Table 2-3 contains the inverter major alarm messages that could appear on the LCD after pressing the Scroll Down key and what each message indicates.

**Table 2-3 Inverter Major Alarm Messages**

<b>Alarm Message</b>	<b>Problem Indication</b>
INV FUSE BLOWN	One or more of the inverter output fuses (F1, F2, or F3) has blown.
TRANSFO OVERTEMP	The inverter transformer (T2) has an overtemperature condition.
INV LEG1 OVERTEMP	The inverter module for phase 1 has an overtemperature condition.
INV LEG2 OVERTEMP	The inverter module for phase 2 has an overtemperature condition.
INV LEG3 OVERTEMP	The inverter module for phase 3 has an overtemperature condition.
S.S. OVERTEMP	The static switch has an overtemperature condition.
LEG1 POW SUP FAULT	The inverter module for phase 1 has a power supply fault.
LEG2 POW SUP FAULT	The inverter module for phase 2 has a power supply fault.
LEG3 POW SUP FAULT	The inverter module for phase 3 has a power supply fault.
LEG1 DESATURATION	The inverter module for phase 1 is not operating in saturation.
LEG2 DESATURATION	The inverter module for phase 2 is not operating in saturation.



**Table 2-3 (Cont.) Inverter Major Alarm Messages**

<b>Alarm Message</b>	<b>Problem Indication</b>
LEG3 DESATURATION	The inverter module for phase 3 is not operating in saturation.
PCB POW SUP FAULT	Logic power supply board (ALIP) fault.
MIN BAT VOLTAGE	The inverter has turned off because of low battery voltage.
INV OV OR UV	The inverter has turned off because of an over/under output voltage condition.
THERM UPS OVERLOAD	The UPS has shut down because of an overtemperature condition.
INV CT FAULT	The inverter output current sensing circuits are not operating correctly.
MAINS2 PH SEQ NOK	The inverter has turned off and prevented a static switch transfer because of an incorrect phase sequence on the bypass ac input (MAINS2) source.
K3N IS OPEN	The inverter output contactor is open.
INV CURRENT LIMIT	The inverter has turned off because of an overload condition on the inverter output.
THERM S.S. OVERLOAD	The static switch has shut down due to an overload condition.



## HA32B UPS BATTERY CABINET

---

### 3.1 INTRODUCTION

This chapter provides a general description, a description of components, and the specifications of the UPS Battery Cabinet. Figure 3-1 depicts the HA32B UPS Battery Cabinet.

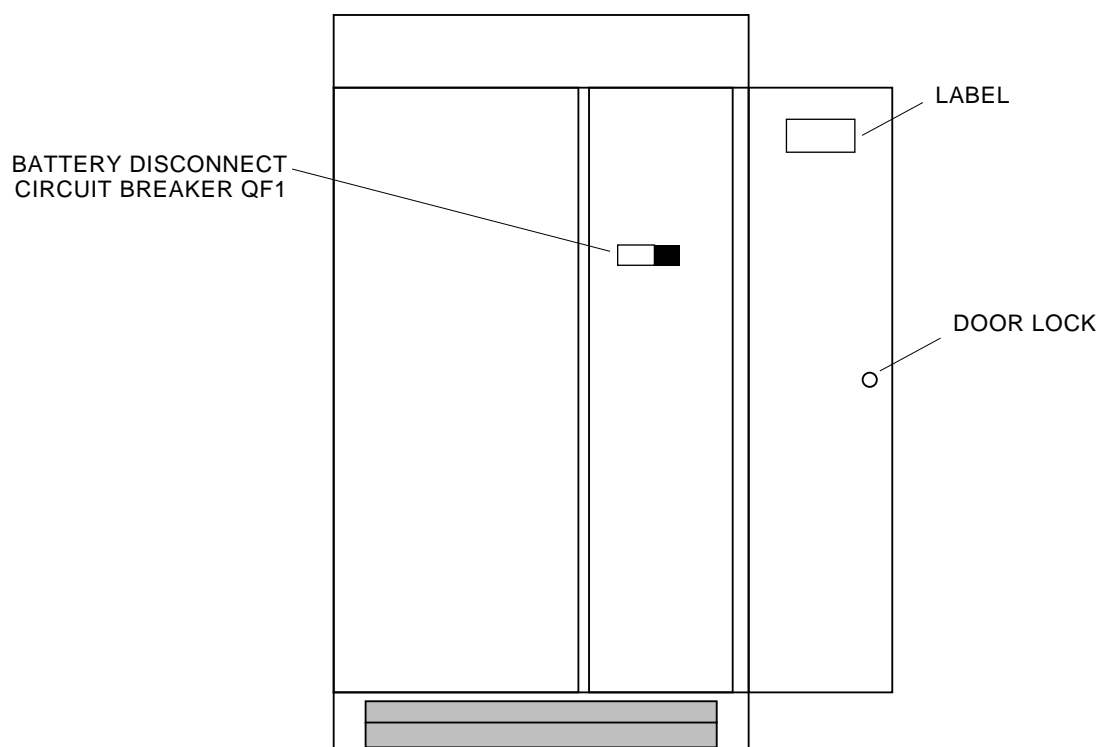

MKV-A2064-91

Figure 3-1 HA32B UPS Battery Cabinet

### 3.1.1 General Description

Each HA32A UPS requires a separate HA32B UPS Battery Cabinet(s), which contains batteries having sufficient ampere-hour (A·h) capacity to support the UPS and its intended load for the protection time specified.

The UPS Battery Cabinets are supplied in compact enclosures similar to the enclosures used for the HA32A UPS. They provide a convenient means of reducing expensive floor space requirements for uninterruptible power systems installations when compared with open-rack battery configurations. In addition to minimizing floor space requirements, installation time is drastically reduced.

The HA32B UPS Battery Cabinet features sealed, maintenance-free, recombination type batteries. The batteries are maintenance-free because they *do not* require that the electrolyte level or the density of the electrolyte be checked periodically. The UPS Battery Cabinets *do* require that the interior of the assembly, including the exterior surfaces of the individual batteries, be kept clear of all foreign matter including dust. The integrity of the individual battery connections must be verified on a yearly basis.

The batteries are sealed and do not release gas under normal operating conditions. They can be used practically anywhere. They operate on the principle of gas recombination within the battery itself. The batteries have a safe, low-pressure venting system that releases excess gas should the internal gas pressure rise to a level above the normal rate, then seals automatically when internal pressure returns to normal.

The batteries are designed for maximum life when operated within an ambient temperature range of 20° to 25°C (68° to 77°F). Operating in a warmer environment increases the ampere-hour capacity of the battery, which extends the protection period in the short run. Operating the batteries at warmer temperatures, however, reduces expected battery life. Conversely, operating in a cooler environment decreases the ampere-hour capacity of the battery, reducing the protection period in the short run, but extending expected battery life.

The HA32B UPS Battery Cabinet provides ready access to the internal batteries, which are rack mounted on easily accessible pull-out rack assemblies. The 31.5-inch cabinet has a single pull-out rack assembly on which the batteries are mounted. All 45-inch and 52-inch wide cabinets have two pull-out rack assemblies on which the batteries are mounted.

### 3.1.2 Specifications

The UPS Battery Cabinet is designed to accommodate multiple combinations of batteries in order to match the requirements of a particular load. A basic 12-volt battery, made up of six series-connected lead-calcium cells, forms the basic building block for all UPS Battery Cabinets. The batteries are series-connected to form a "string" of batteries that provides the required dc voltage level to operate with the HA32A UPS.

### 3.1.3 Protection Period

Each UPS Battery Cabinet is designed to provide a specified backup or protection time for the equipment with which it is designed to operate. This protection time is based on the equipment operating at rated load (full kVA rating at 0.8 power factor lagging) in an ambient temperature of 25°C (77°F). Operating at a warmer temperature extends this protection period but reduces expected battery life. Operating at a cooler temperature shortens this protection period but increases expected battery life.

## 3.2 OPERATION

This section describes standard operating procedures, including battery disconnect circuit breaker QF1 operation, normal operation, and emergency power off (EPO) operation.

The UPS Battery Cabinet should be kept in a charged condition for optimum performance over the extended life of the batteries. A discharged UPS Battery Cabinet should be recharged as soon as possible and should not be allowed to remain in a discharged state for an extended period of time (battery life could be significantly reduced).

If the equipment that the UPS Battery Cabinet is intended to protect is taken out of service for an extended period of time, the UPS Battery Cabinet should be left connected to the operating rectifier/battery charger in each system to maintain the batteries in an optimum condition.

### 3.2.1 Battery Disconnect Circuit Breaker QF1

QF1 allows you to manually connect or disconnect the UPS Battery Cabinet from its intended load, the HA32A UPS. QF1 also provides overload protection in the event that the intended load demands more current than the UPS Battery Cabinet can safely furnish. Each UPS Battery Cabinet has a battery disconnect circuit breaker QF1, therefore, if the system has two UPS Battery Cabinets, there are two QF1s.

#### 3.2.1.1 Normal Operation

Under normal operation, QF1 acts as an on/off switch to connect or disconnect the UPS Battery Cabinet from the HA32A UPS.

#### 3.2.1.2 QF1 Trip

The reasons that circuit breaker QF1 might trip include:

- Overload
- Low battery voltage
- Emergency power off (EPO) command from the HA32A UPS

#### 3.2.1.3 QF1 Reset

After correcting the condition that caused QF1 to trip, manually place QF1 to the off position, then place QF1 to the on position to reset it.

### 3.2.2 Emergency Power Off (EPO)

The UPS Battery Cabinet disconnect circuit breaker QF1 is connected to the UPS emergency power off system. The two EPO keys, located on the HA32A UPS SS&CP, are pushed simultaneously to initiate an emergency power off signal. When the UPS Battery Cabinet disconnect circuit breaker QF1 receives this signal, QF1 turns off and the UPS Battery Cabinet is disconnected from the UPS. The EPO keys should only be used for emergency situations. **DO NOT** use the EPO keys for a normal shutdown sequence.



## HA32C/D/E UPS AUXILIARY CABINET

### 4.1 INTRODUCTION

This section describes the HA32C/D/E UPS Auxiliary Cabinets, features, and options.

#### 4.1.1 General Description

The HA32C/D/E UPS Auxiliary Cabinet is available in three different configurations for use with the HA32A UPS. The configurations are:

1. Isolation Transformer (HA32D-xx)

The isolation transformer can be configured in one of three ways:

- a. UPS Input Isolation Transformer: The isolation transformer provides complete electrical isolation between the ac input source and the input of the UPS (rectifier/battery charger and battery). See Figure 4-1.

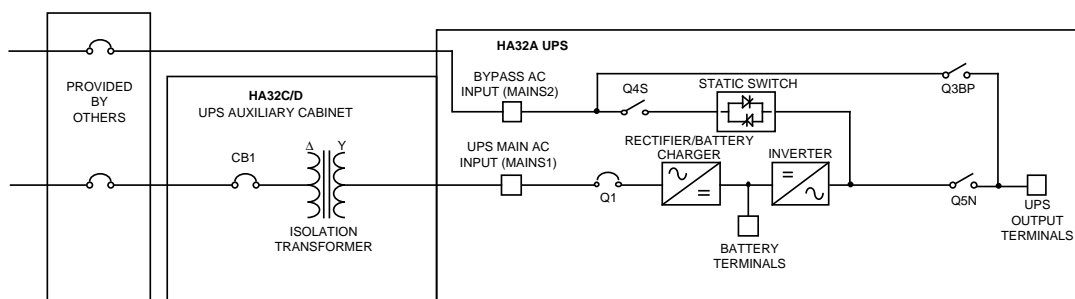

MKV-A2066-91

Figure 4-1 UPS Input Isolation Transformer Configuration

- b. Bypass Input Isolation Transformer: The isolation transformer provides complete electrical isolation between the ac input source and the critical load when the UPS is operated on static bypass or manual bypass. See Figure 4-2.

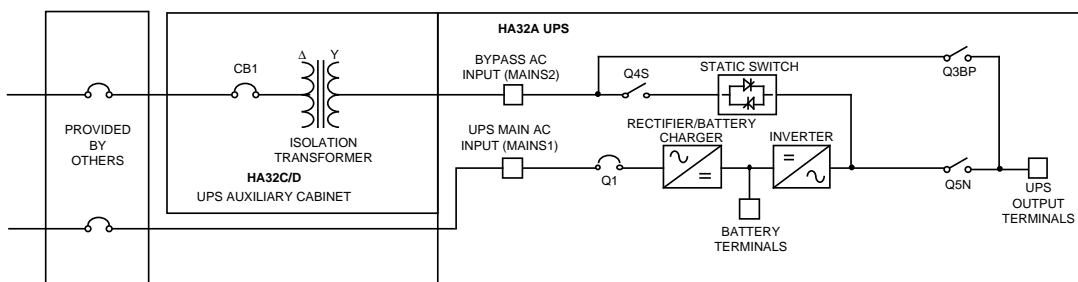

MKV-A2067-91

Figure 4-2 Bypass Input Isolation Transformer Configuration

- c. UPS Input and Bypass Input Isolation Transformer: The isolation transformer can be connected to provide electrical isolation for both the main ac input (MAINS1) and the bypass ac input (MAINS2) to the UPS. See Figure 4-3.

**NOTE**

To connect the isolation transformer described in configuration "c" above, the UPS main ac input (MAINS1) and bypass ac input (MAINS2) voltages must be from the same source. See Figure 4-3.

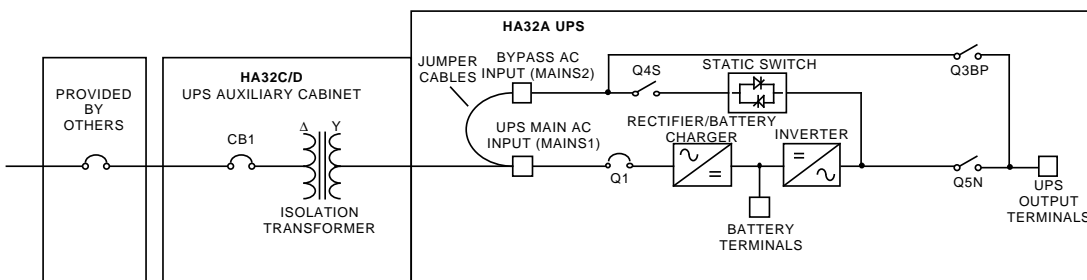

MKV-A2068-91

Figure 4-3 UPS Input and Bypass Input Isolation Transformer Configuration



2. UPS Input Harmonic Current Filter (HA32E-Px)

The input harmonic current filter limits the amount of current distortion fed back onto the ac input source to less than 10% when the HA32A UPS is operating at full load.

3. Isolation Transformer and UPS Input Harmonic Current Filter (HA32C-xx)

The UPS Auxiliary Cabinet can be supplied with both of these UPS options installed within the single Auxiliary Cabinet enclosure.

**NOTE**

**The HA32C-Ex or HA32D-Ex UPS Auxiliary Cabinet models or the HA33D-Ex UPS CSA Cabinet are required for use with the HA32A-Ax UPS for systems with a 600 Vac input. These UPS Auxiliary Cabinets and the UPS CSA Cabinets house the isolation/step-down transformer. The transformer secondary voltage is 208 Vac and the transformer supplies both the UPS main ac input (MAINS1) and the bypass ac input (MAINS2). See Figure 4-3.**

#### **4.1.2 Input Circuit Breaker (CB1)**

Each HA32C and HA32D UPS Auxiliary Cabinet is provided with an input circuit breaker (CB1). This breaker is located on the ac input source to the UPS Auxiliary Cabinet. It provides overcurrent protection and mechanical isolation for maintenance purposes.

## 4.2 OPERATION

This section describes standard operating procedures, including operation of the input circuit breaker (CB1), the input isolation transformer, and the input harmonic current filter.

### 4.2.1 Input Circuit Breaker (CB1)

CB1 allows you to manually connect or disconnect the input isolation transformer located inside the HA32C or HA32D UPS Auxiliary Cabinet. CB1 also provides extra protection against overload conditions. Overload conditions cause the input circuit breaker CB1 to trip.

The position of CB1 is monitored by the HA32A UPS. If CB1 trips, the LCD on the HA32A UPS will display: "ENVIRONMENTAL FAULT".

Check the position of circuit breaker CB1. If it is in the center position (trip condition), reset the circuit breaker by pushing down on the handle, then close the circuit breaker by pulling up on the handle.

When circuit breaker CB1 is opened or tripped, the rectifier/battery charger in the HA32A UPS will shut down, and the inverter will operate on battery if the UPS Auxiliary Cabinet is configured as shown in Figure 4-1 or Figure 4-3. If the UPS Auxiliary Cabinet is configured as shown in Figure 4-2, the HA32A UPS will remain on-line, but additional alarms will be generated.

### 4.2.2 Input Isolation Transformer

The input isolation transformer is protected against thermal overload and is continuously monitored by the HA32A UPS. Should the input isolation transformer overheat, the rectifier/battery charger will shut down and the inverter will operate on battery. The LCD on the HA32A UPS will display: "ENVIRONMENTAL FAULT".

### 4.2.3 Input Harmonic Current Filter

The input harmonic current filter is protected by three (3) fuses: F1, F2, and F3. Should one or more of these fuses open, the LCD on the HA32A UPS will display: "ENVIRONMENTAL FAULT".

The failure of these fuses will not cause the HA32A UPS rectifier/battery charger to shut down.

## HA33D/F UPS CSA CABINET

### 5.1 INTRODUCTION

This section describes the HA33D/F UPS CSA Cabinets, features, and options.

#### 5.1.1 General Description

The HA33D/F UPS CSA Cabinet is available in two different configurations for use with the HA32A UPS. The configurations are:

1. CSA Assembly Only (HA33F-Px)

A UPS CSA Cabinet with only a CSA assembly is used when 208 Vac utility power is available for the HA32A UPS. The UPS CSA Cabinet provides power from the ac input source for both the main ac input (MAINS1) and the bypass ac input (MAINS2) in the UPS.

The CSA assembly contains a mechanical contactor to provide feedback protection during a utility power outage if there is a shorted SCR in the static switch. See Figure 5-1.

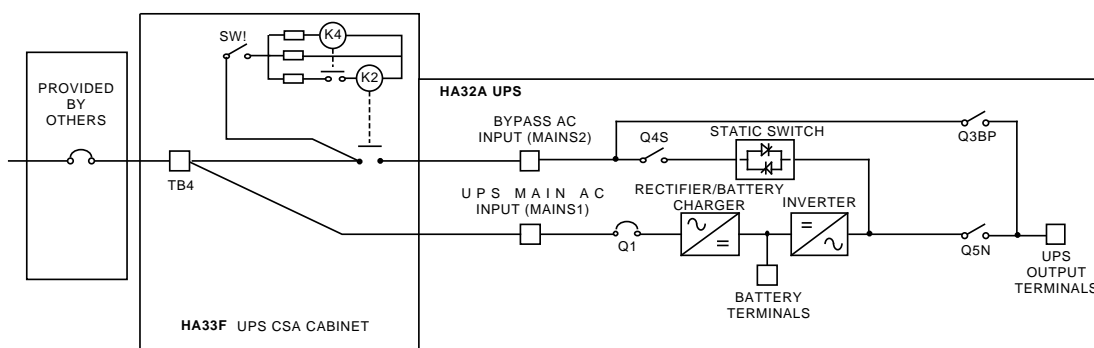

MKV-A2221-91

Figure 5-1 CSA Assembly Only Configuration

## 2. CSA Assembly and Isolation/Step-down Transformer Configuration (HA33D-Ex)

This configuration of the UPS CSA Cabinet is used when 600 Vac utility power is available for the HA32A UPS. The CSA assembly and the isolation/step-down transformer are both installed within the single UPS CSA Cabinet enclosure.

### NOTE

**The HA32C-Ex or HA32D-Ex UPS Auxiliary Cabinet models, or the HA33D-Ex UPS CSA Cabinet are required for use with the HA32A-Ax UPS for systems with a 600 Vac input. These UPS Auxiliary Cabinets and the UPS CSA Cabinets house the isolation/step-down transformer. The transformer secondary voltage is 208 Vac, and the transformer supplies both the UPS main ac input (MAINS1) and the bypass ac input (MAINS2). See Figure 5-2.**

The isolation/step-down transformer provides a step-down of 600 Vac to 208 Vac and electrical isolation for both the main ac input (MAINS1) and the bypass ac input (MAINS2) to the UPS. See Figure 5-2.

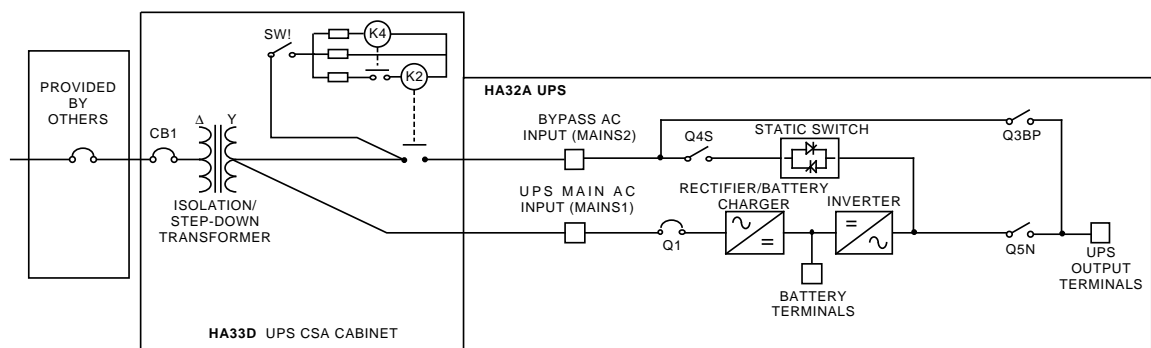

MKV-A2220-91

**Figure 5-2 CSA Assembly and Isolation/Step-Down Transformer Configuration**

### 5.1.2 Contactor Control Switch (SW1)

Each HA33D and HA33F UPS CSA Cabinet contains a contactor control switch (SW1). This switch is closed to allow the ac input source to energize the mechanical contactor which provides power to the bypass ac input (MAINS2) of the UPS.

Switch SW1 is used for maintenance purposes to electrically isolate the contactor control fuses (F4, F5, and F6) and the coils of contactors K2 and K4.

### 5.1.3 Input Circuit Breaker (CB1)

The HA33D UPS CSA Cabinets are provided with an input circuit breaker (CB1). This breaker is located on the ac input source to the UPS CSA Cabinet. It provides overcurrent protection and mechanical isolation for maintenance purposes.

## 5.2 OPERATION

This section describes standard operating procedures, including operation of the input circuit breaker (CB1), the contactor control switch (SW1), and the input isolation/step-down transformer.

During normal operation, the UPS inverter supplies power to the load while the static switch is off and in standby mode. The contactor control switch SW1 in the UPS CSA Cabinet is manually closed to allow the ac input source to energize contactor coils K2 and K4, causing their contacts to close. This allows the ac input source to be gated to the bypass ac input (MAINS2) of the UPS.

If the ac input source power fails, the contactor coils of K2 and K4 will deenergize causing their contacts to open. When the contacts of contactor K2 open, a mechanical isolation between the bypass ac input (MAINS2) in the UPS and the ac input source will exist. This will prevent the flow of power from the inverter output to the ac input source in the event of a static switch SCR failure (short circuit).

### 5.2.1 Input Circuit Breaker (CB1)

CB1 allows you to manually connect or disconnect the input isolation/step-down transformer located inside the HA33D UPS CSA Cabinet. CB1 also provides extra protection against overload conditions. Overload conditions cause the input circuit breaker CB1 to trip.

The position of CB1 is monitored by the HA32A UPS. If CB1 trips, the LCD on the HA32A UPS will display: "ENVIRONMENTAL FAULT".

Check the position of circuit breaker CB1. If it is in the center position (trip condition), reset the circuit breaker by pushing down on the handle, then close the circuit breaker by pulling up on the handle.

When circuit breaker CB1 is opened or tripped, the rectifier/battery charger in the HA32A UPS will shut down, and the inverter will operate on battery.

### 5.2.2 Contactor Control Switch (SW1)

The contactor control switch SW1 is closed during normal operation. This allows the ac input source to energize the K4 and K2 contactor coils and gate the ac input source to the bypass ac input (MAINS2) of the UPS. The contactor control circuit is protected by three 5 Amp fuses: F4, F5, and F6.

The failure of one or more of these fuses will deenergize the K2 contactor and disconnect the ac input source from the bypass ac input (MAINS2) of the UPS, but will not cause the HA32A UPS rectifier/battery charger to shut down.

Contactor control switch SW1 is used for maintenance purposes to electrically isolate the contactor control fuses (F4, F5, and F6) and the coils of contactors K2 and K4.

### 5.2.3 Input Isolation/Step-Down Transformer

The input isolation/step-down transformer is protected against thermal overload and is continuously monitored by the HA32A UPS. Should the input isolation/step-down transformer overheat, the rectifier/battery charger will shut down and the inverter will operate on battery. The LCD on the HA32A UPS will display: "ENVIRONMENTAL FAULT".



# 6

## HA32J/K UPS DISTRIBUTION CABINET

---

### 6.1 INTRODUCTION

This chapter introduces the HA32J/K UPS Distribution Cabinet. The equipment is described, followed by a description of available options. Figure 6-1 depicts the HA32J/K UPS Distribution Cabinet.

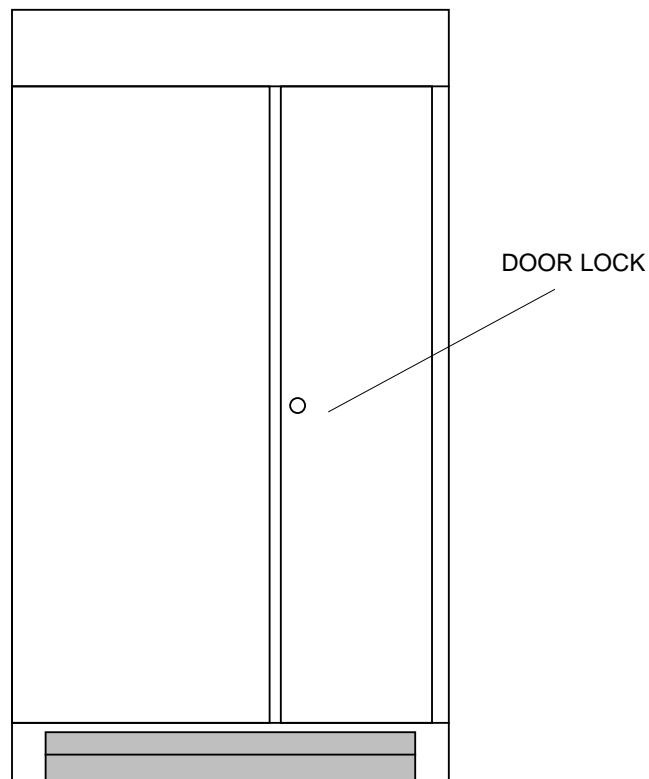

MKV-A2069-91

Figure 6-1 HA32J/K UPS Distribution Cabinet

### 6.1.1 System Description

The HA32J/K UPS Distribution Cabinet provides the means to distribute power from the HA32A UPS to the user's intended equipment. The HA32J/K UPS Distribution Cabinet is furnished in an enclosure matching the other HA3000 series equipment. The HA32J/K is designed to attach to the right side of the HA32A UPS, or to either the right side of the HA32C/D/E UPS Auxiliary Cabinet or the HA33D/F UPS CSA Cabinet if these options are purchased.

The HA32J is furnished with one 42-pole position, 225-ampere rated panelboard, and one 225-ampere rated branch circuit breaker. The HA32K is furnished with two 42-pole position, 225-ampere rated panelboards, and two 225-ampere rated branch circuit breakers.

A single-line diagram of the HA32A UPS and the HA32J/K UPS Distribution Cabinet is shown in Figure 6-2.

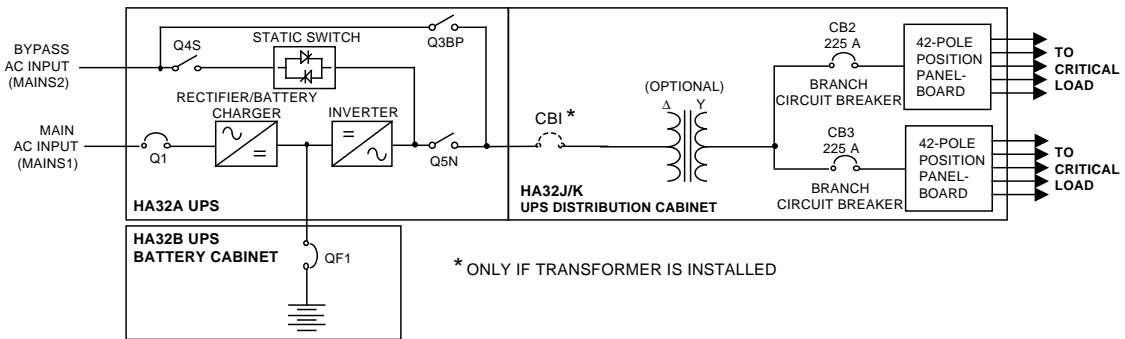

MKV-A2070-91

Figure 6-2 HA32J/K and HA32A Single-Line Diagram



## 6.2 OPERATION

This section describes the operation of circuit breaker(s) CB1, CB2, and CB3, and the operation of the output circuit breaker(s). Figure 6-3 shows the location of the circuit breakers.

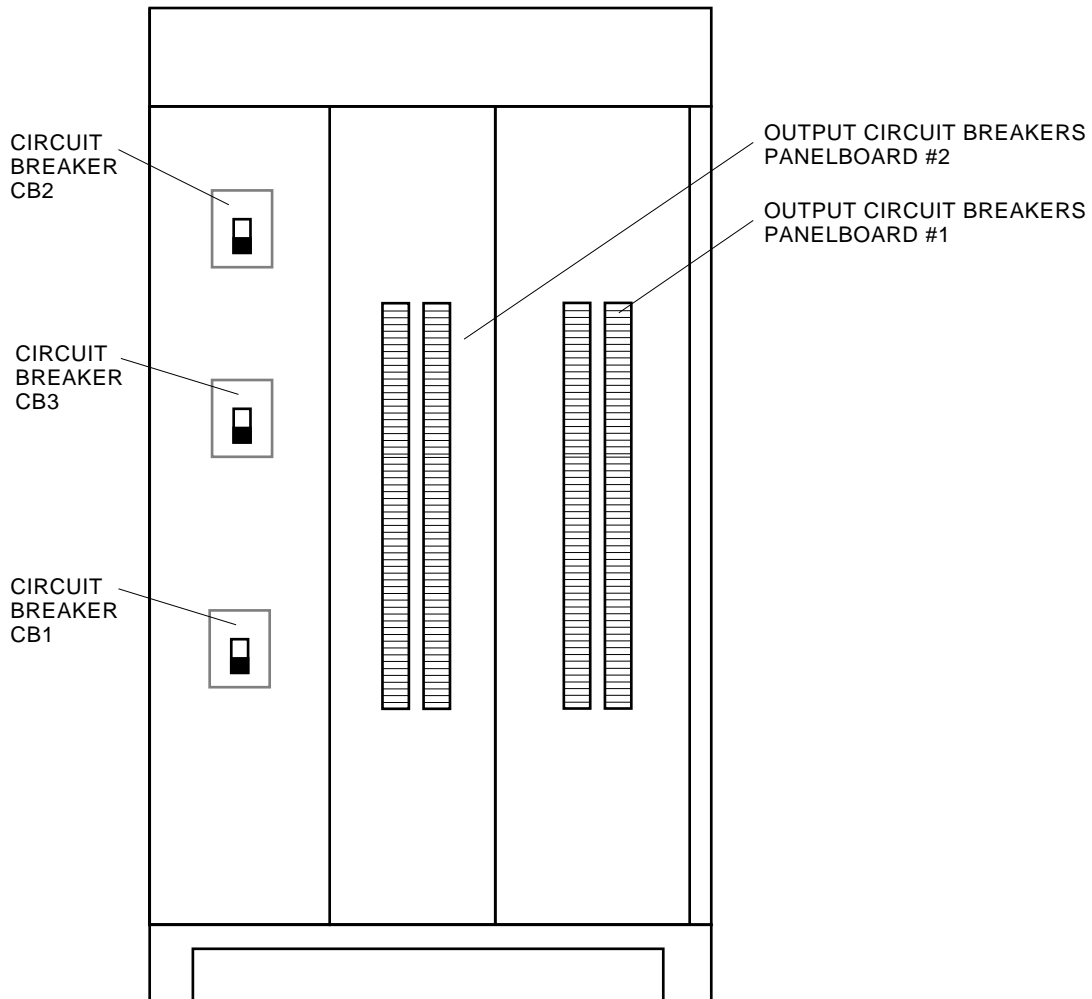

MKV-A2071-91

**Figure 6-3 HA32J/K Circuit Breaker Locations**

### 6.2.1 Circuit Breaker(s) CB1, CB2, and CB3

Circuit breaker CB1 is present in a UPS Distribution Cabinet with an isolation transformer. All power to a UPS Distribution Cabinet with an isolation transformer passes through CB1.

Circuit breakers CB2 and CB3 allow you to manually connect or disconnect the HA32J/K UPS Distribution Cabinet panelboards to the output of the HA32A UPS. They also provide extra protection against overload conditions. Overload conditions cause the branch circuit breaker(s) to trip.

The branch circuit breaker(s) handle has three positions:

1. OFF or circuit breaker open = handle in the bottom position
2. TRIP or circuit breaker open = handle in the middle position
3. ON or circuit breaker closed = handle in the top position

To reset the branch circuit breaker after it has tripped, push the handle down to the OFF position, then move the handle up to the ON position.

### **6.2.2 Output Circuit Breaker(s)**

The output circuit breaker(s) allow you to manually connect or disconnect each load connected to the output of the HA32J/K UPS Distribution Cabinet without affecting the other loads. The output circuit breaker(s) protects the individual loads against overload conditions. Overload conditions cause the output circuit breaker(s) to trip.

The output circuit breaker(s) handle has three positions:

1. OFF or circuit breaker open
2. TRIP or circuit breaker open
3. ON or circuit breaker closed

To reset an output circuit breaker after it has tripped, push the handle to the OFF position, then move the handle to the ON position.

# A

## SPECIFICATIONS

---

The following are electrical and environmental specifications for the HA32A UPS.

### AC Input (MAINS1) Ratings

Refer to Table A-1 for nominal voltage (Vac) values available.

<b>Voltage:</b>	As specified, nominal +10%, -15%
<b>Frequency:</b>	Nominal, $\pm 5\%$
<b>Phases:</b>	Three-phase, phase rotation A, B, C
<b>Wires:</b>	Three, plus equipment ground
<b>Current:</b>	See Table A-2
<b>Power Factor:</b>	0.82 lagging minimum at full load output, nominal input voltage, and normal float voltage on the battery

### Bypass AC Input (MAINS2) Ratings

<b>Voltage:</b>	Must match UPS nominal output voltage $\pm 10\%$
<b>Frequency Window:</b>	Nominal, $\pm 0.25$ , 0.50, 0.75, or 1.0 Hz. Standard setting for bypass input frequency window is $\pm 0.50$ Hz, unless otherwise specified when ordered. The frequency window can be changed after the unit is installed, but only an authorized Digital Services representative can modify the equipment.
<b>Phases:</b>	Three-phase, phase rotation A, B, C
<b>Wires:</b>	Four-wire wye
<b>Current:</b>	See Table A-2
<b>Power Factor:</b>	Load-dependent

**Inverter AC Output Ratings**

Refer to Table A-1 for nominal voltage (Vac) values available.

<b>Voltage:</b>	Nominal value $\pm 1\%$ for all conditions of line, load, and temperature
<b>Frequency:</b>	Normally synchronized to the bypass ac input source (when available); otherwise, the output frequency is the nominal value $\pm 0.1\%$
<b>Phases:</b>	Three-phase, phase rotation A, B, C
<b>Wires:</b>	Three or four. The UPS inverter output is normally a wye configuration with the neutral grounded. A three-wire delta load can be connected to the UPS inverter output, but the phase connections cannot be grounded.
<b>Current:</b>	See Table A-2
<b>Power Factor:</b>	The UPS inverter output is rated at full kVA, 0.8 power factor lagging load
<b>Slew Rate:</b>	The rate of change of the UPS inverter output frequency, while tracking within the frequency window, when synchronizing to the bypass ac input source, or when going to a free-running condition after losing ac input power, is 1 Hz/second maximum
<b>Overload Characteristics:</b>	<p>Applies to the UPS output when operating from either the bypass ac input source or the UPS inverter output:</p> <p>125% for 10 minutes 150% for 1 minute</p> <p>Overloads in excess of 150% or exceeding the overload time periods previously indicated, will cause the load to be transferred from the UPS inverter output to the bypass ac input source, provided the sources are synchronized. Once the load is transferred to the bypass ac input source after exceeding the time periods previously indicated, the timed periods will start again for operation on the UPS static switch. If the load does not return to less than the unit's fill load rating prior to completing the timed overload periods, the load will be disconnected.</p>
<b>Dynamic Characteristics:</b>	<p>Peak voltage deviation on the UPS inverter output is listed below for the conditions indicated:</p> <p>50% step load change <math>\pm 3\%</math> maximum 100% step load change <math>\pm 5\%</math> maximum</p>
<b>Dynamic Response:</b>	The UPS inverter output voltage returned to $\pm 1\%$ of nominal within one cycle after experiencing a 100% step load change

**Battery Characteristics**

<b>DC Voltage Range:</b>	325 Vdc minimum 436 Vdc maximum
<b>DC Current Required:</b>	See Table A-2

**Environmental Characteristics****Temperature:**

- **Operating Range:** 0° to 40°C (32° to 104°F), excluding battery
- **Nonoperating and Storage:** -25° to 70°C (-13° to 158°F)

**NOTE**

**Batteries should be stored only in a fully charged condition at temperatures not exceeding 25°C (77°F). Storage at higher temperatures will reduce storage life and may reduce battery life.**

**Relative Humidity:** 0 to 95%, noncondensing

**Recommended Environment:** Computer room or other temperature-controlled environment

**Recommended Temperature:** 20° to 30°C (68° to 86°F)  
Battery protection time is based on a 25°C (77°F) ambient temperature

**Recommended Relative Humidity:** 50%

## A-4 SPECIFICATIONS

The following tables contain the specifications for the HA32A UPS, the HA32B UPS Battery Cabinet, the HA32C/D/E UPS Auxiliary Cabinet, the HA33D/F UPS CSA Cabinet, and the HA32J/K UPS Distribution Cabinet.

**Table A-1 Standard HA32A UPS Models**

<b>Model Number</b>	<b>Output Rating kVA/kW</b>	<b>Nominal Input Voltage 3<math>\Phi</math> (Volts)</b>	<b>Input CB Rating (Amps)</b>	<b>Output Voltage 3<math>\Phi</math> (Volts)</b>	<b>Width mm/in</b>	<b>Approx. Weight kg/lbs</b>	<b>Heat Loss (Full Load) BTU/hr</b>
HA32A-AH	20/16	208	80	208Y/120	800/31.5	488/1,075	8,189
HA32A-DH	20/16	220	80	220Y/127	800/31.5	488/1,075	8,189
HA32A-BH	20/16	480	40	208Y/120	800/31.5	488/1,075	8,189
HA32A-CH	20/16	480	40	480Y/277	800/31.5	488/1,075	8,189
HA32A-AK	40/32	208	175	208Y/120	800/31.5	628/1,385	15,013
HA32A-DK	40/32	220	175	220Y/127	800/31.5	628/1,385	15,013
HA32A-BK	40/32	480	80	208Y/120	800/31.5	628/1,385	15,013
HA32A-CK	40/32	480	80	480Y/277	800/31.5	628/1,385	15,013
HA32A-AM	60/48	208	250	208Y/120	1,143/45.0	783/1,725	20,130
HA32A-DM	60/48	220	250	220Y/127	1,143/45.0	783/1,725	20,130
HA32A-BM	60/48	480	100	208Y/120	1,143/45.0	783/1,725	20,130
HA32A-CM	60/48	480	100	480Y/277	1,143/45.0	783/1,725	20,130
HA32A-AN	80/64	208	350	208Y/120	1,143/45.0	1,023/2,250	26,954
HA32A-DN	80/64	220	350	220Y/127	1,143/45.0	1,023/2,250	26,954
HA32A-BN	80/64	480	150	208Y/120	1,143/45.0	1,023/2,250	26,954
HA32A-CN	80/64	480	150	480Y/277	1,143/45.0	1,023/2,250	26,954

**Height, all models: 1,402 mm/55.18 in**  
**Depth, all models: 817 mm/32.18 in**

Table A-2 HA32A Currents

	HA32A-xH	HA32A-xK	HA32A-xM	HA32A-xN
<b>Output Power Rating</b>				
<b>kVA/kW</b>	20/16	40/32	60/48	80/64
<b>Unit Nominal AC Input Current (Amperes) @ Nominal Input Voltage</b>				
<b>208 Vac</b>	61.5	121.5	180.4	237.7
<b>220 Vac</b>	58.2	114.9	170.5	224.8
<b>480 Vac</b>	29.3	52.7	78.2	103.0
<b>Unit AC Output and Bypass AC Input Current (Amperes) @ Nominal Voltage (Note 1)</b>				
<b>Full Load Continuous</b>				
<b>208Y/120</b>	55.5	111.0	166.5	222.1
<b>220Y/127</b>	52.5	105.0	157.5	209.9
<b>480Y/277</b>	24.1	48.1	72.2	96.2
<b>125% Overload for 10 Minutes</b>				
<b>208Y/120</b>	69.4	138.8	208.2	277.6
<b>220Y/127</b>	65.6	131.2	196.8	262.4
<b>480Y/277</b>	30.1	60.1	90.2	120.3
<b>150% Overload for 1 Minute</b>				
<b>208Y/120</b>	83.3	166.5	249.8	333.1
<b>220Y/127</b>	78.7	157.5	236.2	314.9
<b>480Y/277</b>	36.1	72.2	108.3	144.3
<b>Maximum Battery Current (Note 2)</b>				
<b>Amperes</b>	54.6	109.2	163.9	218.5

**NOTES:**

1. As a minimum, bypass ac input (MAINS2) power should match the UPS output rating. The bypass ac input should have a continuous rating of 125% of the UPS output power rating to supply fault-clearing current.
2. Battery wiring should be sized to keep the total cable voltage drop to less than 0.5 Vdc at the current shown.

**Table A-3 UPS Battery Cabinet Model Numbers**

<b>Model Number</b>	<b>kVA Rating</b>	<b>Nominal Protection in Minutes</b>	<b>Circuit Breaker (QF1) Rating in Amperes</b>	<b>Width of Battery Cabinet mm/in</b>	<b>Approx. Installed Weight kg/lbs</b>
HA32B-AH	20	5	90	800/31.5	530/1,169
HA32B-CH	20	15	90	800/31.5	530/1,169
HA32B-FH	20	30	90	1,143/45.0	905/1,995
HA32B-AK	40	5	125	800/31.5	530/1,169
HA32B-CK	40	14	125	1,143/45.0	905/1,995
HA32B-FK <sup>1</sup>	40	30	125	2 x 1,143/45.0	2 x 826/1,820
HA32B-AM	60	5	175	1,143/45.0	905/1,995
HA32B-CM <sup>1</sup>	60	10	175	2 x 1,143/45.0	2 x 826/1,820
HA32B-FM <sup>1</sup>	60	30	175	2 x 1,143/45.0	2 x 826/1,820
HA32B-AN	80	5	225	1,143/45.0	905/1,995
HA32B-CN <sup>1</sup>	80	14	225	2 x 1,143/45.0	2 x 826/1,820
HA32B-FN <sup>1</sup>	80	22	225	2 x 1,143/45.0	2 x 905/1,995

<sup>1</sup>Consists of two battery cabinets with same dimensions and weight.

**Depth of all models: 817 mm/32.18 in**  
**Height of all models: 1,402 mm/55.18 in**

**Table A-4 Maximum DC Current Requirements**

<b>UPS Battery Cabinet Model Number</b>	<b>Maximum DC Current (Amperes)</b>
HA32B-XH	54.6
HA32B-XK	109.2
HA32B-XM	163.9
HA32B-XN	218.5



**Table A-5 Interbattery Link Torque Values**

<b>Manufacturer</b>	<b>Model No.</b>	<b>Initial Torque Values</b>	<b>Subsequent Torque Values</b>
Yuasa	DM33-12	1.8 N·m (16.3 inch-pounds)	1.2 N·m (10.85 inch-pounds)
Yuasa	DM55-12	1.8 N·m (16.3 inch-pounds)	1.2 N·m (10.85 inch-pounds)
Yuasa	DM80-12	1.8 N·m (16.3 inch-pounds)	1.2 N·m (10.85 inch-pounds)
Johnson Controls	UPS12-95	3.9 N·m (35.0 inch-pounds)	3.4 N·m (30.0 inch-pounds)
Johnson Controls	UPS12-135	3.9 N·m (35.0 inch-pounds)	3.4 N·m (30.0 inch-pounds)
Johnson Controls	UPS12-225	3.9 N·m (35.0 inch-pounds)	3.4 N·m (30.0 inch-pounds)
Johnson Controls	JC12250	Not applicable	Not applicable

**Table A-6 UPS Auxiliary Cabinet Weights and Dimensions**

<b>Output Rating (kVA)</b>	<b>HA32D-XX Isolation Transformer Only (kg/lbs)</b>	<b>HA32E-PX Input Current Filter Only (kg/lbs)</b>	<b>HA32C-XX Isolation Transformer and Input Current Filter (kg/lbs)</b>
20	204/450	154/341	268/591
40	249/550	169/374	328/724
60	327/720	214/473	450/993
80	386/850	260/573	556/1,255

**Depth of all models: 817 mm/32.18 in**  
**Height of all models: 1,402 mm/55.18 in**  
**Width of all models: 477 mm/18.78 in**

**Table A-7 HA32C/D/E UPS Auxiliary Cabinet Electrical Specifications**

<b>Model Number</b>	<b>Output Rating (kVA)</b>	<b>Input Voltage (Vac)</b>	<b>Input Current (Amps)</b>	<b>Output Voltage (Vac)</b>	<b>Output Current (Amps)</b>	<b>Input CB Rating (Amps)</b>
<b>With Input Isolation Transformer and Harmonic Current Filter</b>						
HA32C-AH	20	208	62	208	62	90
HA32C-BH	20	480	30	208	62	40
HA32C-CH	20	480	30	480	30	40
HA32C-DH	20	220	59	220	59	90
HA32C-EH	20	600	24	208	62	40
HA32C-AK	40	208	122	208	122	175
HA32C-BK	40	480	53	208	122	90
HA32C-CK	40	480	53	480	53	90
HA32C-DK	40	220	115	220	115	175
HA32C-EK	40	600	43	208	122	60
HA32C-AM	60	208	181	208	181	250
HA32C-BM	60	480	79	208	181	100
HA32C-CM	60	480	79	480	79	100
HA32C-DM	60	220	171	220	171	250
HA32C-EM	60	600	63	208	181	80
HA32C-AN	80	208	238	208	238	350
HA32C-BN	80	480	103	208	238	150
HA32C-CN	80	480	108	480	103	150
HA32C-DN	80	220	225	220	225	350
HA32C-EN	80	600	93	208	238	100
<b>With Input Isolation Transformer Only</b>						
HA32D-AH	20	208	62	208	62	90
HA32D-BH	20	480	30	208	62	40
HA32D-CH	20	480	30	480	30	40

**NOTES:**

1. NA = Not Applicable
2. The Input Harmonic Current Filter option is not voltage dependent. It does not increase the input or output current.
3. The UPS Auxiliary Cabinet models with an Input Isolation Transformer (HA32C and HA32D) contain an input circuit breaker (CB1).

**Table A-7 (Cont.) HA32C/D/E UPS Auxiliary Cabinet Electrical Specifications**

<b>Model Number</b>	<b>Output Rating (kVA)</b>	<b>Input Voltage (Vac)</b>	<b>Input Current (Amps)</b>	<b>Output Voltage (Vac)</b>	<b>Output Current (Amps)</b>	<b>Input CB Rating (Amps)</b>
HA32D-DH	20	220	59	220	59	90
HA32D-EH	20	600	24	208	62	40
HA32D-AK	40	208	122	208	122	175
HA32D-BK	40	480	53	208	122	90
HA32D-CK	40	480	53	480	53	90
HA32D-DK	40	220	115	220	115	175
HA32D-EK	40	600	43	208	122	60
HA32D-AM	60	208	181	208	181	250
HA32D-BM	60	480	79	208	181	100
HA32D-CM	60	480	79	480	79	100
HA32D-DM	60	220	171	220	171	250
HA32D-EM	60	600	63	208	181	80
HA32D-AN	80	208	238	208	238	350
HA32D-BN	80	480	103	208	238	150
HA32D-CN	80	480	108	480	103	150
HA32D-DN	80	220	225	220	225	350
HA32D-EN	80	600	93	208	238	100
<b>With Harmonic Current Filter Only</b>						
HA32E-PH	20	NA	NA	NA	NA	NA
HA32E-PK	40	NA	NA	NA	NA	NA
HA32E-PM	60	NA	NA	NA	NA	NA
HA32E-PN	80	NA	NA	NA	NA	NA

**NOTES:**

1. NA = Not Applicable
2. The Input Harmonic Current Filter option is not voltage dependent. It does not increase the input or output current.
3. The UPS Auxiliary Cabinet models with an Input Isolation Transformer (HA32C and HA32D) contain an input circuit breaker (CB1).

**Table A-8 UPS CSA Cabinet Weights and Dimensions**

<b>Output Rating (kVA)</b>	<b>HA33D-XX Isolation/Step-Down Transformer and CSA Assembly (kg/lbs)</b>	<b>HA33F-XX CSA Assembly Only (kg/lbs)</b>
20	211/465	98/215
40	256/565	98/215
60	333/735	98/215
80	392/865	98/215

**Depth of all models: 817 mm/32.18 in**  
**Height of all models: 1,402 mm/55.18 in**  
**Width of all models: 477 mm/18.78 in**

**Table A-9 HA33D/F UPS CSA Cabinet Electrical Specifications**

<b>Model Number</b>	<b>Output Rating (kVA)</b>	<b>Input Voltage (Vac)</b>	<b>Output Voltage (Vac)</b>	<b>Input CB Rating (Amps)</b>
<b>With Input Isolation/Step-Down Transformer and CSA Assembly</b>				
HA33D-EH	20	600	208	40
HA33D-EK	40	600	208	60
HA33D-EM	60	600	208	80
HA33D-EN	80	600	208	100
<b>With CSA Assembly Only</b>				
HA33F-PH	20	NA	NA	NA
HA33F-PK	40	NA	NA	NA
HA33F-PM	60	NA	NA	NA
HA33F-PN	80	NA	NA	NA

**NOTES:**

1. NA = Not Applicable
2. The CSA assembly is not voltage dependent.
3. The UPS CSA Cabinet models with an Input Isolation/Step-Down Transformer (HA33D) contain an input circuit breaker (CB1).

**Table A-10 UPS Distribution Cabinet Specifications**

<b>Model Number</b>	<b>UPS Output Rating (kVA)</b>	<b>Input Voltage (Vac)</b>	<b>Maximum Input Current (Amps)</b>	<b>Output Voltage (Vac)</b>	<b>Maximum Output Current (Amps)</b>	<b>Weight (kg/lbs)</b>
HA32J-AT <sup>1</sup>	20 - 40	208/220	222	208/220	222	225/495
HA32K-AT <sup>1</sup>	60 - 80	208/220	222	208/220	222	239/525
HA32J-AH	20	208	55.5	208	55.5	352/775
HA32J-BH	20	480	24.1	208	55.5	352/775
HA32J-DH	20	220	55.5	220	55.5	352/775
HA32J-AK	40	208	111	208	111	389/855
HA32J-BK	40	480	48.1	208	111	389/855
HA32J-DK	40	220	111	220	111	389/855
HA32K-AK	40	208	111	208	111	399/880
HA32K-BK	40	480	48.1	208	111	399/880
HA32K-AM	60	208	166.5	208	166.5	461/1,015
HA32K-BM	60	480	72.2	208	166.5	461/1,015
HA32K-DM	60	220	166.5	220	166.5	461/1,015
HA32K-AN	80	208	222	208	222	516/1,135
HA32K-BN	80	480	96.2	208	222	516/1,135
HA32K-DN	80	220	222	220	222	516/1,135

<sup>1</sup>These models DO NOT contain an isolation/step-down transformer. The input voltage will equal the output voltage.

The HA32J-XX models contain one (1) 42-pole panelboard.

The HA32K-XX models contain two (2) 42-pole panelboards.

**Height, all models: 1,402 mm/55.18 in**  
**Depth, all models: 817 mm/32.18 in**  
**Width, all models: 800 mm/31.50 in**



## GLOSSARY

---

/

Represents "and/or"

%

Percent; of each hundred.

°F

Degrees Fahrenheit

°C

Degrees Centigrade

±

Plus or minus

∅

Phase

Ω

Ohms

**A, B, C**

Normal sequence of phases in three phase power.

**AC or ac**

Alternating current.

**Ambient air temperature**

The temperature of the surrounding air.

**ANSI**

American National Standards Institute.

**AWG**

American Wire Gauge, formerly Brown & Sharp gauge; a standard for sizing cross-sectional area of wire conductors, and for measuring sheet metal thickness.

**B or BAT or BATT.**

Battery.

**BAT TRANS.TEST**

Battery Transfer Test; simulates a main input power failure and tests inverter operation on the battery for two minutes.

## GLOSSARY-2

### **BATTERY OV**

Battery overvoltage.

### **BATTERY UV**

Battery undervoltage.

### **BREAKER**

Circuit breaker.

### **British Thermal Unit**

A unit of heat equal to 252 calories (see Calories below). One British Thermal Unit is defined as the amount of energy required to raise the temperature of one pound of water by one degree Fahrenheit.

### **Btu**

British Thermal Unit.

### **Btu/Hr**

British Thermal Units per hour.

### **BYP**

Bypass.

### **BYPASS**

Manual Bypass; manual bypass without interruption to the load using the Bypass Circuit Breaker Q3BP in conjunction with Q4S and Q5N.

### **BYPASS AC INPUT**

The MAINS2 power source.

### **BYPASS PROCEDURE**

Main Menu selection for access to the procedure for manually transferring the load to the bypass ac input (MAINS2) source, and returning the load to the inverter output.

### **Calorie**

A unit of heat. One calorie is defined as the amount of energy required to raise the temperature of one gram of water by one degree Centigrade.

### **Carrier**

The company or individual responsible for delivering goods from one area to another.

### **CAPAC DISCHARGING**

Capacitors discharging; indicates that the capacitors are discharging. The voltage across the capacitor terminals is indicated on the next LCD line. When this indication appears on the LCD, wait until the capacitor voltage reaches zero before carrying out any operations on the equipment.

### **CB**

Circuit breaker.

### **CH**

(CHarger) rectifier/battery charger.



**CHANGE OK=1**

Prompt requesting replacement of subassembly indicated on the preceding LCD line. By entering 1, you indicate to the UPS Monitor that the change has been made.

**CHARG.**

(CHARGer) rectifier/battery charger.

**CHARGE I MAX**

Prompt for entry of the maximum battery charge current value.

**CHARGER ACQUISITION FAULT**

The rectifier/battery charger is not receiving information required for operation.

**CHARGER CT FAULT**

Indicates a fault on current transformer T1 or T2, which is installed on the rectifier/battery charger input lines.

**CHECK LOAD**

Transfer the load to the bypass ac input (MAINS2) source, and check to see that the currents of the three phases do not exceed the inverter current rating ( $I_n = P_n / 3U_n$ , where  $I_n$  = inverter nominal current rating in kVA,  $P_n$  = inverter current rating in kVA, and  $U_n$  = inverter line-to-neutral voltage).

**CHECK MAINS**

Measure the main ac input (MAINS1) voltages to ensure that they are within tolerance (+10%, -15%).

**CHGR.**

Rectifier/battery charger.

**COMMUNICATION**

Main Menu selection providing access to parameter programming for communication with a remote computer system.

**Conduit**

A flexible or rigid tube surrounding electrical conductors.

**CT**

Current transformer.

**Curr.**

Current.

**Current Rating**

The maximum current that a piece of electrical equipment was designed to carry.

**DC or dc**

Direct current.

**DC FAULT**

Indicates an internal fault at the dc voltage level (between the rectifier/battery charger, the inverter, and the battery).

**DESIG.**

Designation.

**DIAGNOSIS**

Main Menu selection providing access to UPS diagnostic routines for troubleshooting the HA32A UPS.

**Earth Ground**

A ground circuit that has contact with the earth.

**Electrician**

Refers to an installation electrician qualified to install heavy-duty electrical components in accordance with national and local codes and regulations. Not qualified to maintain or repair electrical or electronic equipment; compare with Technician.

**EPO**

Emergency power off.

**FAN FAILURE**

Failure of a UPS enclosure cooling fan. For normal room temperatures, the remaining fan is sufficient for continued UPS operation.

**FAULT CLEAR**

Clearing of memorized faults after the condition(s) causing the fault(s) has been corrected.

**FORCED OFF**

Inverter shutdown, with an 0.8 second load interruption caused by incorrect bypass ac input (MAINS2) characteristics.

**FORCE ON**

Load transferred to inverter with an 0.8 second interruption.

**FORCE TRANSFER**

Prompt requesting password entry to obtain load transfer to inverter after an interruption of 0.8 seconds.

**FREE RUNNING**

Indicates that the inverter frequency is stable and independent of the bypass ac input (MAINS2) frequency.

**FREQ**

Frequency.

**Fusible**

Capable of being melted with heat.

**GEN SET DESYNCHRO**

Inverter frequency desynchronization action with respect to the bypass ac input (MAINS2) source upon transfer to a motor-generator set.

**GEN SET POW LIM**

Motor-generator set power limit; reducing the power consumed by the rectifier/battery charger during operation of the UPS on a motor-generator set.

**GND**

Ground.

**GRAD CH STOP**

Gradual rectifier/battery charger shutdown; a gradual shutdown of the rectifier/battery charger initiated by the closure of an external contact.

**Hz**

Hertz; one cycle per second equals one Hertz.

**I**

Current.

**I SENSOR FAULT**

Indicates a fault on the inverter output current sensor.

**Input Branch Circuit**

The input circuit from the building power panel circuit breaker to the UPS module.

**INV**

Inverter.

**INV FUSE BLOWN**

Inverter fuse(s) blown; indicates that fuse F1, F2, or F3 has blown on the inverter output.

**INV LEG THERMO**

Indicates overtemperature on the transistors of the inverter leg.

**INV NON SYNC**

Indicates that the phase shift between the inverter and the bypass ac input (MAINS2) source is outside of tolerance ( $\pm 3^\circ$ ). Transfer of the load without an interruption is not possible.

**INV STOP DISABLED**

Indicates that the inverter cannot be stopped using the INVERTER STOP command because the bypass ac input (MAINS2) characteristics are incorrect, which would lead to an 0.8 second interruption to the load if the inverter were stopped.

**INVERT 2 PHASES**

The main ac input (MAINS1) or bypass ac input (MAINS2) connections are incorrect. Swap any two phases to correct the phase sequence.

**INVERTER ACQUISITION FAULT**

Indicates that the inverter is not receiving information required for operation.

**INVERTER FORCED**

Load supplied by the inverter regardless of circumstances [transfer to bypass ac input (MAINS2) source is locked out].

**INVERTER RETURN**

Prompt requesting entry of the number 2 for access to the load return to inverter procedure from maintenance bypass status.

**I/P**

Input.

**kVA**

Kilovolt-amperes; a measure of apparent power.

## GLOSSARY-6

### **KW**

Kilowatt; a measure of real power.

### **LCD**

Liquid-crystal display.

### **LED**

Light-emitting diode.

### **LEG**

Inverter phase.

### **LEG DESATURATION**

Indicates that the inverter power transistors are not operating in saturation.

### **LEG POWER SUP FAULT**

Inverter leg power supply fault; indicates a power supply fault on the PC board controlling the transistors of the inverter leg.

### **Load**

The equipment being protected by the UPS.

### **!LOAD INTERRUPT!**

Warning that impending action will cause an 0.8 second load interruption.

### **MAINS1**

Main ac input power source.

### **MAINS2**

Bypass ac input power source.

### **MAINS2 FU RC BLOWN**

Indicates blown fuses on the voltage surge suppression circuit connected to the bypass ac input (MAINS2) power source.

### **MAINS2 NOT OK**

Indicates that the bypass ac input (MAINS2) voltage or frequency is outside tolerance limits ( $\pm 10\%$  and  $\pm 0.5\%$  of nominal, respectively).

### **MAINS2 PHASING**

Indicates zero volts on one phase of the bypass ac input (MAINS2) power source.

### **MAINS PH SEQ NOK**

Mains phase sequence not okay; indicates that the phase rotation is incorrect. Swap any two phases to correct this situation.

### **MAX**

Maximum.

### **MCM**

Thousand circular mil; wire sizing method for multiple stranded conductors over 4/0 AWG in diameter. M is for the Roman Numeral symbol for 1,000.

### **MG**

Motor-generator set; an alternator (generator) driven by an electric motor.

**MOV**

Metal-oxide varistor; a device used to suppress voltage transients (spikes) on an electrical line.

**NEC**

National Electrical Code, ANSI/NFPA 70 (latest issue).

**NFPA**

National Fire Protection Association.

**NO. or No.**

Part number.

**NOK**

Not okay.

**OF**

Overfrequency.

**OF/UF**

Over- or underfrequency.

**O.T.**

Out of tolerance.

**OUTPUT OVERLOAD**

Indicates that an overload (110%) has occurred.

**OUTSIDE CONTACT**

An external contact supplied by the user that: initiates independent inverter frequency, initiates a reduction in the power consumed on the main ac input (MAINS1) power source, forces the load to be supplied by the inverter, or initiates a gradual rectifier/battery charger shutdown.

**OV**

Overvoltage.

**OV/UV**

Over- or undervoltage.

**Packing List**

The list of articles included in a given shipment.

**PCB**

Printed circuit board; refers to the electronic cards used in the equipment.

**PERSONALIZATION**

Main menu heading for access to the programming of nonstandard equipment characteristics.

**P.F.**

Power factor.

**PH**

Phase.

## GLOSSARY-8

### **PIA**

Plug-in assembly.

### **Power Factor**

The ratio (decimal) of real power to apparent power, with current specified as leading or lagging voltage.

### **POWER SUPPLY FAULT**

Indicates a fault on the control electronics power supply board ALIP.

### **Q1**

UPS main ac input (MAINS1) circuit breaker designation.

### **Q3BP**

Manual bypass circuit breaker designation.

### **Q4S**

Bypass ac input (MAINS2) circuit breaker designation.

### **Q5N**

UPS output isolation circuit breaker designation.

### **QF1**

UPS Battery Cabinet circuit breaker designation.

### **Remote Emergency Power Off**

A switch used to shut down electrical equipment from a location away from the equipment.

### **REPO**

Remote emergency power off.

### **REP**

Replacement.

### **SCR**

Silicon-controlled rectifier.

### **SEQ**

Sequence.

### **S.G.**

Specific gravity.

### **Shipping Damage**

Any damage done to an article while it is in transit.

### **Shipping Pallet**

A platform on which articles are fixed for shipping.

### **Specific Gravity**

The ratio of the weight of a given volume of one substance (such as battery electrolyte) to that of an equal volume of a reference substance (such as water).

**SPEED = BAUDS**

Programming of the transmission speed in bits per second (baud rate).

**S.S. or STATIC SW**

Static switch; used to transfer the load to the bypass ac input (MAINS2) power source without interruption to the load.

**S.S. PROTECTIVE DEVICE FAULT**

Indicates a fault on the voltage surge protection circuit connected to the bypass ac input (MAINS2) power source.

**S.S. THERMO**

Indicates an overtemperature condition on the SCRs of the static switch assembly.

**SS&CP**

System status and control panel; the front panel of the UPS that contains the controls and indicators.

**SYNC. or SYNCHRO**

Synchronization.

**SW**

Switch.

**SW TO MAN BY-PASS**

Switch to manual bypass.

**Technician**

Refers to an electronic technician qualified to maintain and repair electronic equipment. Not qualified to install electrical wiring. Compare with Electrician.

**Temp.**

Temperature.

**TEST POSITION**

Indicates that the inverter has been stopped and is not available. The load is on manual bypass (Q4S is open, Q5N is open, and Q3BP is closed).

**THERMAL OVERLOAD**

Indicates that an overload (between 120% and 150%) has occurred.

**THERMO**

Abbreviation for overtemperature.

**TRANSF.**

Transfer.

**TRANSFO**

Transformer.

**TRANSFO THERMO**

Indicates an overtemperature condition on the inverter output transformer T5.

**U**

Voltage.

## GLOSSARY-10

**UF**

Underfrequency.

**UL**

Underwriter's Laboratories, Inc.

**UPS**

Uninterruptible power system.

**UV**

Undervoltage.

**Vac**

Volts of alternating current.

**Vb**

Battery voltage (in volts).

**Vdc**

Volts of direct current.

**Via**

By way of.

**VPC**

Volts per cell; the measure of the electrical potential of a storage cell, such as a battery.

**W/O**

Without.

**XFMR**

Transformer.



# Index

---

## A

Alarms, 2-34  
  major, 2-35  
  minor, 2-34

## B

Battery disconnect circuit breaker QF1,  
  3-3  
Battery transfer test, 2-15  
BATT TRANS. TEST menu, 2-15  
BYPASS PROCEDURE menu, 2-17

## C

COMMANDS menu, 2-20  
  battery boost charge, 2-22  
  battery equalization charge, 2-22  
  inverter start and stop, 2-21, 2-32  
  language selection, 2-23  
  rectifier/battery charger start and stop,  
    2-20, 2-32  
  resetting faults stored in memory, 2-21  
  synchronous/nonsynchronous operation,  
    2-21  
COMMUNICATION menu, 2-28  
Controls  
  electromechanical, 2-6  
  programmable, 2-6

## D

DC Ground Fault Detector, 1-9  
DIAGNOSIS menu, 2-24  
DISPLAY CONTRAST menu, 2-14

## H

HA320-A3 Remote Alarm Panel, 1-8  
HA320-AA/AB Remote Status Panel, 1-8  
HA320-B1 Smoke Detector, 1-9  
HA320-C2 DC Ground Fault Detector,  
  1-9  
HA32A UPS

HA32A UPS (Cont.)  
  manual bypass, 1-4, 2-33  
  system status and control panel  
    (SS&CP), 2-1

HA32B UPS Battery Cabinet, 1-7, 3-1  
HA32C/D/E UPS Auxiliary Cabinet, 1-7,  
  4-1

HA32J/K UPS Distribution Cabinet, 1-8,  
  6-1

HA33D/F UPS CSA Cabinet, 1-7, 5-1

## I

INVERTER ON/OFF menu, 2-12  
Inverter start and stop, 2-21, 2-32

## M

Major alarms, 2-35  
  inverter, 2-36  
  rectifier/battery charger, 2-35  
Manual bypass, 1-4, 2-33  
Menus, 2-8  
  BATT TRANS. TEST menu, 2-15  
  BYPASS PROCEDURE menu, 2-17  
  COMMANDS menu, 2-20  
  COMMUNICATION menu, 2-28  
  DIAGNOSIS menu, 2-24  
  DISPLAY CONTRAST menu, 2-14  
  INVERTER ON/OFF menu, 2-12  
  PERSONALIZATION menu, 2-28  
  START-UP menu, 2-10  
Minor alarms, 2-34

## O

Operating modes  
  automatic, 2-29  
    input power restored/battery  
      charging, 2-31  
    inverter shutdown or major  
      overload, 2-31  
    normal operation, 2-29  
    on battery operation, 2-30  
  manual, 2-32  
    inverter start and stop, 2-32  
    manual bypass, 2-33

## 2 Index

### Operating modes

- manual (Cont.)
  - rectifier/battery charger start and stop, 2-32
  - return to normal operation from manual bypass, 2-33

### Options

- DC Ground Fault Detector, 1-9
- Remote Alarm Panel, 1-8
- Remote Emergency Power Off (REPO), 1-9
- Remote Status Panel, 1-8
- Smoke Detector, 1-9
- UPS Auxiliary Cabinet, 1-7
- UPS CSA Cabinet, 1-7
- UPS Distribution Cabinet, 1-8

### UPS Distribution Cabinet (Cont.)

- input circuit breakers, 6-3
- output circuit breakers, 6-4

## P

- PERSONALIZATION menu, 2-28
- Programmable controls and indicators, 1-6

## R

- Rectifier/battery charger, 1-4
- Rectifier/battery charger start and stop, 2-20, 2-32
- Remote Alarm Panel, 1-8
- Remote Emergency Power Off (REPO), 1-9
- Remote Status Panel, 1-8
- Return to normal operation from manual bypass, 2-33

## S

- Smoke Detector, 1-9
- Specifications, A-1
- START-UP menu, 2-10
- Static inverter, 1-4
- Static switch, 1-4
- System description, 1-2
- System status and control panel (SS&CP), 2-1

## U

- UPS Auxiliary Cabinet, 1-7, 4-1
  - input circuit breaker CB1, 4-3, 4-4
  - input harmonic current filter, 4-4
  - input isolation transformer, 4-4
- UPS Battery Cabinet, 1-7, 3-1
- UPS CSA Cabinet, 1-7, 5-1
  - contactor control switch (SW1), 5-2, 5-3
  - input circuit breaker CB1, 5-2, 5-3
  - input isolation/step-down transformer, 5-3
- UPS Distribution Cabinet, 1-8, 6-1