



# Expansion Storage Pedestal

---

User's Guide

Order Number: EK-SMCPA-UG. C01

**Digital Equipment Corporation  
Maynard, Massachusetts**

---

Third Edition, January 1995

The information in this document is subject to change without notice and should not be construed as a commitment by Digital Equipment Corporation. Digital Equipment Corporation assumes no responsibility for any errors that may appear in this document.

Restricted Rights: Use, duplication, or disclosure by the U.S. Government is subject to restrictions as set forth in subparagraph (c) (1) (ii) of the Rights in Technical Data and Computer Software clause at DFARS 252.227-7013.

Digital Equipment Corporation does not give a warranty of any kind regarding the fitness or applicability of the information content for a particular purpose. The user assumes all responsibility for understanding the interrelationships of this enclosed information with other affected software or system products.

The disclosure of this information does not grant to the user a license under any patents, pending patents, trademarks, or copyrights or other rights of Digital Equipment Corporation, or of any third party.

FCC Notice: This equipment generates, uses, and may emit radio frequency energy. The equipment has been type tested and found to comply with the limits for a Class A computing device pursuant to Subpart J of Part 15 of FCC Rules, which are designed to provide reasonable protection against such radio frequency interference when operated in a commercial environment. Any changes or modifications made to this equipment may void the user's authority to operate the equipment. Operation of this equipment in a residential area may cause interference, in which case the user, at his own expense, may be required to take measures to correct the interference.

Copyright © Digital Equipment Corporation 1993, 1995  
All Rights Reserved

Printed in U. S. A

The following are trademarks of Digital Equipment Corporation:  
StorageWorks, and the Digital Logo.

All other trademarks and registered trademarks are the property of their respective owners.

# Contents

---

<b>Revision Record</b> .....	vii
<b>About This Guide</b> .....	ix
<b>1 Introduction</b>	
1.1 Product Description.....	1-1
1.2 Pedestal Features.....	1-2
1.3 Pedestal Component Description.....	1-2
1.3.1 StorageWorks Building Blocks (SBBs) .....	1-2
1.3.2 Blower Unit .....	1-3
1.3.3 Pedestal Cabinet.....	1-3
<b>2 Installation</b>	
2.1 Introduction.....	2-1
2.2 Unpacking.....	2-1
2.3 SCSI Cables and Connectors .....	2-1
2.3.1 Low-Density and High-Density SCSI Connectors .....	2-1
2.3.2 SCSI Connector Securing Mechanisms .....	2-2
2.3.3 Storage Pedestal SCSI Connectors .....	2-3
2.3.4 SCSI "A" Cable .....	2-3
2.4 Connecting the Pedestal to the Host System .....	2-3
2.4.1 SCSI "A" Cable Connections .....	2-3
2.4.1.1 Routing SCSI Cable under Rear Bezel .....	2-4
2.4.1.2 Routing SCSI Cable through Removable Tab.....	2-4
2.4.2 Power Cable Connection.....	2-6
2.4.3 Installing Devices.....	2-7
2.5 Power-On Test.....	2-9
<b>3 Pedestal Configuration Rules</b>	
3.1 Device Addresses .....	3-1
3.1.1 Setting the Address of Storage Devices .....	3-2
3.2 Pedestal Power .....	3-2
3.3 StorageWorks Building Blocks (SBBs) .....	3-3
3.4 SCSI Bus .....	3-4
3.4.1 SCSI Bus Length inside the Pedestal.....	3-4
3.4.2 Reconfiguring the Pedestal for Two SCSI Buses .....	3-4
3.4.3 Configuring Two Pedestals for a Single SCSI Bus .....	3-6

## 4 Maintenance

4.1	Pedestal Indicators.....	4-1
4.1.1	Pedestal Status .....	4-1
4.1.2	Power Supply LEDs.....	4-1
4.1.3	Battery Backup Unit LEDs.....	4-3
4.1.4	SBB Status LEDs.....	4-3
4.2	Replacing a Storage SBB .....	4-5
4.3	Replacing a Power SBB .....	4-6
4.3.1	Replacing a Primary Pedestal (Non-Redundant) Power Supply .....	4-6
4.3.2	Replacing a Redundant Power Supply .....	4-7
4.3.3	Replacing a Pedestal BBU .....	4-7
4.4	Replacing a Fan Assembly (Blower).....	4-8
4.5	Remove/Install Front/Rear Bezel.....	4-9
4.5.1	Remove Front/Rear Bezel .....	4-9
4.5.2	Install Front/Rear Bezel .....	4-10
4.6	Troubleshooting the Pedestal.....	4-11

## Chapter 5 Illustrated Parts

### Appendix A StorageWorks Product Specifications

A.1	Input Power Requirements .....	A-1
A.2	Power Units .....	A-1
A.3	Physical Specifications .....	A-2
A.4	Environmental Specifications .....	A-3
A.5	Environmental Stabilization .....	A-4

### Appendix B Manufacturer's Declarations

Glossary .....	Glossary-1
----------------	------------

Index .....	Index-1
-------------	---------

Reader Comment Form .....	Inside Back Cover
---------------------------	-------------------

### Figures

1-1	StorageWorks Expansion Storage Pedestal .....	1-1
1-2	Expansion Storage Pedestal Components (Typical Configuration).....	1-3
1-3	Pedestal Slot Locations .....	1-4
2-1	50-Pin Low-Density Connector .....	2-2
2-2	50-Pin High-Density Connector.....	2-2
2-3	Pedestal-to-Host Connection Diagram .....	2-4
2-4	Routing SCSI Cable under Rear Bezel.....	2-5
2-5	Routing SCSI Cable through Side Filler Panel .....	2-5
2-6	Power Cable Connection .....	2-7
2-7	Installing Storage Devices .....	2-8
2-8	Power Supply SBB LEDs.....	2-9
2-9	Storage SBB LEDs.....	2-10
3-1	Typical StorageWorks Modular Pedestal - Device Addresses .....	3-1

**Figures (cont'd)**

3-2	5.25 and 3.5-inch Device Address Switch Locations.....	3-2
3-3	Typical 3.5-inch SBB.....	3-3
3-4	Typical 5.25-inch SBB.....	3-3
3-5	Backplane Configuration for Two SCSI Buses.....	3-5
3-6	Pedestal-to-Host Connections for Two SCSI Buses.....	3-5
3-7	Configuring Two Pedestals for a Slow, Single SCSI Bus.....	3-6
4-1	Power Supply LEDs.....	4-2
4-2	Battery Backup Unit (BBU) LEDs.....	4-3
4-3	3.5-inch SBB LEDs.....	4-4
4-4	5.25-inch SBB LEDs.....	4-4
4-5	Removing a Storage Device.....	4-6
4-6	Removing a Blower.....	4-9
4-7	Removing Front/Rear Bezel.....	4-10
4-8	Installing Front/Rear Bezel.....	4-10
5-1	Pedestal Field Replaceable Parts.....	5-1

**Tables**

2-1	SCSI Connector Securing Mechanisms.....	2-2
2-2	SCSI "A" Cables.....	2-3
2-3	Country-Specific Power Cords.....	2-6
3-1	Storage Device Address Switch Settings.....	3-2
3-2	SCSI Bus Lengths.....	3-4
4-1	Pedestal and Single Power Supply Status LEDs.....	4-2
4-2	Pedestal and Dual Power Supply LEDs.....	4-2
4-3	Battery Backup Unit (BBU) Status LEDs.....	4-3
4-4	SBB Status LEDs.....	4-5
5-1	Pedestal Field Replaceable Parts.....	5-2
A-1	StorageWorks Power Units.....	A-1
A-2	StorageWorks Expansion Storage Pedestal Physical Specifications.....	A-2
A-3	Environmental Specifications.....	A-3
A-4	Thermal Stabilization Specifications.....	A-4

# Revision Record

---

*This Revision Record provides a concise publication history of this guide. It lists the manual revision levels, release dates, and reasons for the revisions. It also describes how the changes to affected pages are marked in the guide.*

---

The following revision history lists all revisions of this publication and their effective dates. The publication part number is included in the *Revision Level* column, with the last entry denoting the latest revision. This publication supports the StorageWorks Expansion Storage Pedestal.

<b>Revision Level</b>	<b>Date</b>	<b>Summary of Changes</b>
EK-SMCPA-UG. A01	September 1993	Original release
EK-SMCPA-UG. B01	December 1993	Adds a procedure to configure two pedestals for a single SCSI bus. Also corrects Figure 3-2 to show proper orientation of 5 1/4" SBB, and makes a power cord part number correction to Table 2-3.
EK-SMCPA-UG. C01	January 1995	Covers move of key lock from bezel door to inside front/rear bezel and move of bezel door hinges from left to right. Adds Figures 4-7 and 4-8. Revises Figures 1-1, 1-2, 2-5, 2-7, and 4-5. Revises Paragraph 4-5 and adds Paragraph 4-6. Corrects jumper and terminator listing in Table 5-1. Incorporates editing changes in Glossary.

# About This Guide

---

*This section identifies the users of this guide and describes the contents and structure. In addition, it includes the conventions used in this guide.*

---

This guide provides installation and maintenance information for the StorageWorks Expansion Storage Pedestal.

## Intended Audience

This guide is intended for people who will install, operate, and maintain StorageWorks Expansion Storage Pedestals.

### NOTE

Installing the StorageWorks Expansion Storage Pedestal requires a general understanding of SCSI devices and basic hardware installation procedures. Otherwise, contact your service representative for installation assistance. If you are unfamiliar with the components of the base subsystem, it is recommended that you review Section 1.3 before proceeding with the installation of your pedestal.

## Document Structure

This guide contains the following chapters:

### Chapter 1: Introduction

**Introduction** gives an overview of the StorageWorks Expansion Storage Pedestal, describes its components, and discusses the pedestal's features.

### Chapter 2: Installation

**Installation** describes unpacking, SCSI cables and connectors, the SCSI cable connection between the pedestal and the host system, the power cable connection, and how to install the components of the pedestal. The chapter also discusses the pedestal power-on test.

### Chapter 3 Pedestal Configuration Rules

**Pedestal Configuration Rules** describes pedestal device addresses, pedestal power, rules for configuring the StorageWorks Building Blocks (SBBs), the SCSI bus, and how to reconfigure the SCSI bus from one to two buses. It also describes how to configure two pedestals for a single SCSI bus.

### Chapter 4 Maintenance

**Maintenance** describes the pedestal SBB LED indicators and how to use them to monitor pedestal operation, how to replace an SBB, the front/rear bezel, and a blower. There is also a brief troubleshooting tip.

### Chapter 5 Illustrated Parts

**Illustrated Parts** shows an exploded view of the pedestal with a related table which lists the part numbers of field replaceable parts.

### Appendix A: StorageWorks Product Specifications

**StorageWorks Product Specifications** list the power, physical, and environmental specifications for the pedestal.

### Appendix B: Manufacturer's Declarations

**Manufacturer's Declarations** describes the Radio Frequency Interference (RFI) and acoustic noise declarations for the pedestal.

## Conventions

This guide uses the following conventions:

### Documentation Conventions

Style	Meaning
boldface type	For emphasis
<i>italic type</i>	<i>For emphasis and manual titles</i>



## Introduction

---

*This chapter provides an overview of the Expansion Storage Pedestal, outlines its features, and describes the system components and options available to the user.*

---

### 1.1 Product Description

The StorageWorks Expansion Storage Pedestal offers a low cost, mass storage solution, and configuration flexibility by allowing you to design your storage array. The pedestal product line consists of a vertical free standing modular storage cabinet with an integral SCSI bus backplane that can be configured for either one or two SCSI buses. The optional modular components available for the pedestal are referred to as StorageWorks Building Blocks (SBBs) which are packaged in 3.5 and 5.25-inch form factors containing devices such as disk, tape, and optical drives, power supplies, and Battery Backup Units (BBUs). Figure 1-1 illustrates a typical pedestal configuration equipped with two 3.5-inch SCSI drives, one 5.25-inch SCSI drive, and a dc power supply.

**Figure 1-1 StorageWorks Expansion Storage Pedestal**

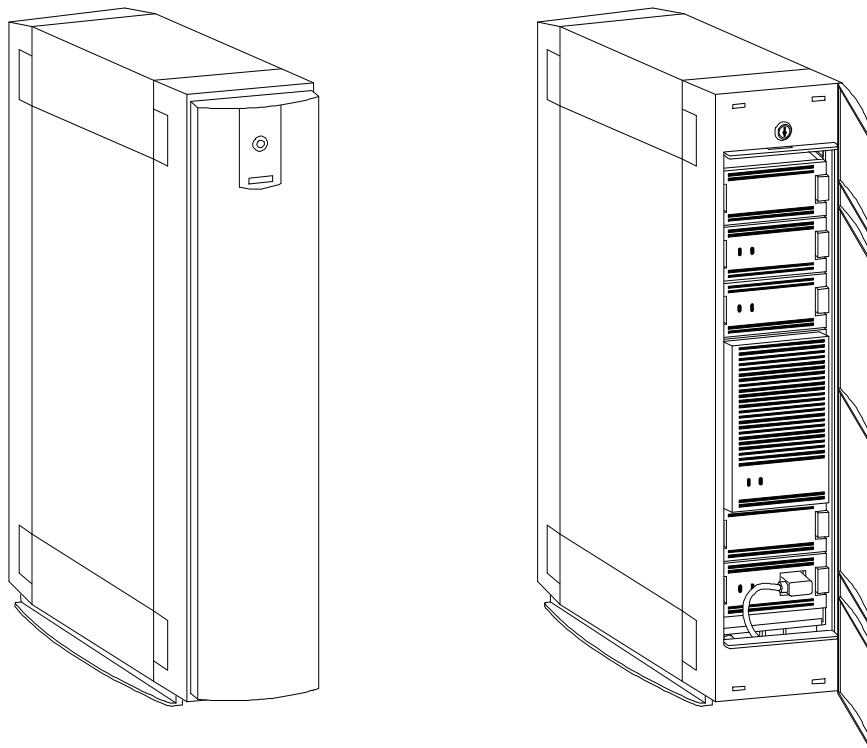

ESP-01

## 1.2 Pedestal Features

The StorageWorks expansion storage pedestal offers the following features:

- Low-cost Small Computer System Interface (SCSI) device storage subsystems
- Snap-in devices for instant installation and removal
- The ability to mix 3.5-inch and 5.25-inch devices
- The freedom to design your own system
- A redundant power option
- Redundant cooling
- Visual fault indicators
- The ability to warm swap SBBs without powering down the pedestal
- Configurable as one or two SCSI buses
- Front and rear bezels that can be locked in place
- Active SCSI bus termination provided
- Pedestals can be "daisy chained" together

## 1.3 Pedestal Component Description

The components of the expansion storage pedestal include the following:

- StorageWorks Building Blocks
  - Disk, tape, and optical devices
  - Industry standard 3.5 and 5.25-inch form factor devices
  - Power supplies and Battery Backup Units
- Fan assemblies (blowers)

Figure 1–2 identifies the components of the expansion storage pedestal configured with a 5.25 and two 3.5-inch disk drives.

### 1.3.1 StorageWorks Building Blocks (SBBs)

All storage devices and power units are mounted inside modular carriers which plug into slots in the pedestal. Each SBB can be removed and replaced without powering down the pedestal. In addition, each SBB has visual status indicator LEDs which are used to determine whether devices are functioning properly.

The 3.5-inch SBB has guides that mate with the grooves in the pedestal slot and ensure that the connector at the rear properly mates with the pedestal connector. When the SBB is fully inserted into the pedestal, the side mounted tabs expand and engage the pedestal to securely mount the SBB. To remove the SBB, you press and hold the two mounting tabs and slide the device out of the pedestal.

The 5.25-inch SBB requires three pedestal slots for mounting. There are guides that mate with the grooves in the pedestal to ensure that the connector at the rear properly mates with the pedestal connector. The insertion and removal of the 5.25-inch SBB is the same as the 3.5-inch device described above. The 5.25-inch SBB contains a switchbank at the

rear of the unit to set the SCSI address of the device manually or automatically to the pedestal's slot number at the user's option.

### 1.3.2 Blower Unit

The expansion storage pedestal contains two blowers for cooling purposes. The blowers are mounted at the rear of the pedestal and obtain their power through a connector on the backplane. The blowers are secured by two "press-to-release" mounting tabs and a single screw in the corner of each blower unit.

**Figure 1–2 Expansion Storage Pedestal Components (Typical Configuration)**

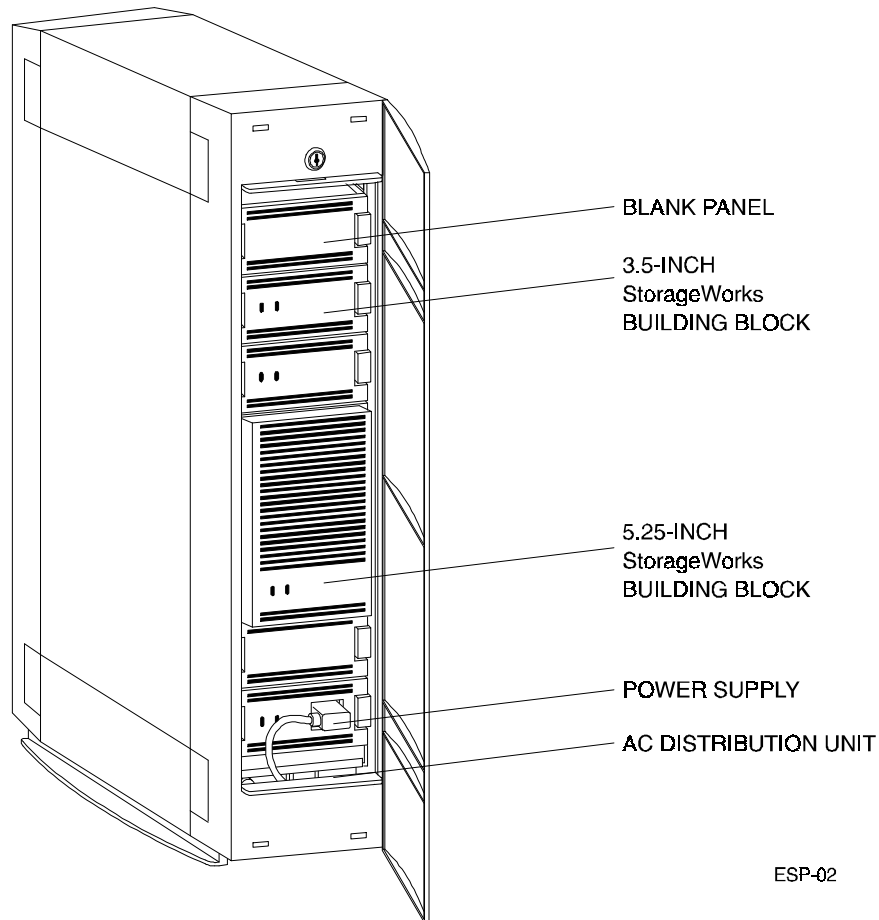

### 1.3.3 Pedestal Cabinet

The floor-mounted pedestal cabinet is a modular storage cabinet that is completely self-contained with its own 3.5-inch SBB power supply, two blowers, and two SCSI cable connectors. The characteristics of the pedestal are outlined below (refer to Figures 1–2 and 1–3).

- The capacity of the pedestal is eight 3.5-inch SBBs
- The pedestal slots are numbered 0 through 7 from top to bottom

- There are seven SCSI bus device addresses (target IDs) 0 through 6 which can be assigned to either 3.5-inch or 5.25-inch SBBs
- The slot numbers and the default SCSI device addresses are the same for slots 0 through 6 (slot 7 is reserved for the power supply and does not have a device address)
- There are two 50-pin, high-density female SCSI connectors on the backplane directly above slot 0
- The ac distribution unit controls prime power (switches) to the power supply installed in slot 7 and the optional redundant power supply in slot 6
- Slot 6 can be used for either a storage SBB, a redundant power supply, or a battery backup unit (BBU)
- The pedestal has two, redundant, replaceable blowers mounted at the rear

**Figure 1–3 Pedestal Slot Locations**

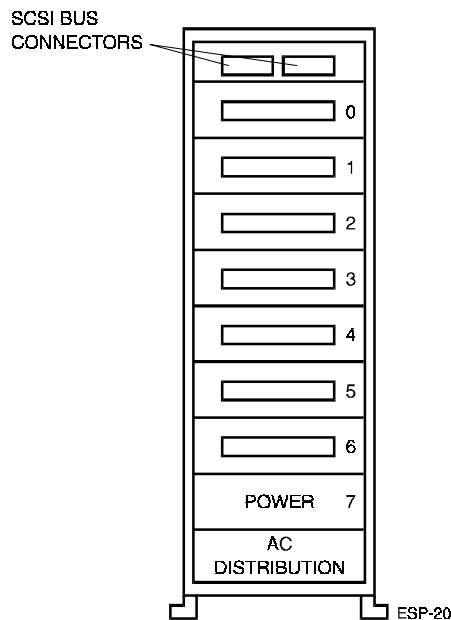

# Installation

---

*This chapter describes the installation procedures required to connect the pedestal to the host, identifies the SCSI cables and connectors, and contains a power-on test to ensure the pedestal is functioning properly.*

---

## 2.1 Introduction

This chapter contains a description of SCSI cables and connectors required to connect the pedestal to the host system and of the power-on test to ensure your storage pedestal installation is functioning properly. The information is divided into the following sections:

- Unpacking
- SCSI cables and connectors
- Connecting the pedestal to the host system
- Power-on test

## 2.2 Unpacking

Before unpacking the expansion storage pedestal or its components, check all packing slips to ensure the correct equipment has been shipped. Also, inspect the shipping containers for damage (crushed corners, punctures, and so forth). All boxes and packing material should be retained at the installation site for reshipment, if necessary.

## 2.3 SCSI Cables and Connectors

SCSI connectors are used on the ends of SCSI cables and on the equipment to which these cables connect. This section discusses the following SCSI connector topics:

- Low-density and high-density SCSI connectors
- SCSI connector securing mechanisms
- Expansion storage pedestal SCSI connectors

### 2.3.1 Low-Density and High-Density SCSI Connectors

There are two types of SCSI cable connectors used at the host end of the SCSI "A" cable which connects the storage pedestal to the host system. The first version of the cable is a 50-pin, low-density connector as shown in Figure 2–1. The second is a smaller 50-pin high-density connector as shown in Figure 2–2. Always determine which type of connector your host system uses before ordering your SCSI cable.

**Figure 2–1 50-Pin Low-Density Connector**

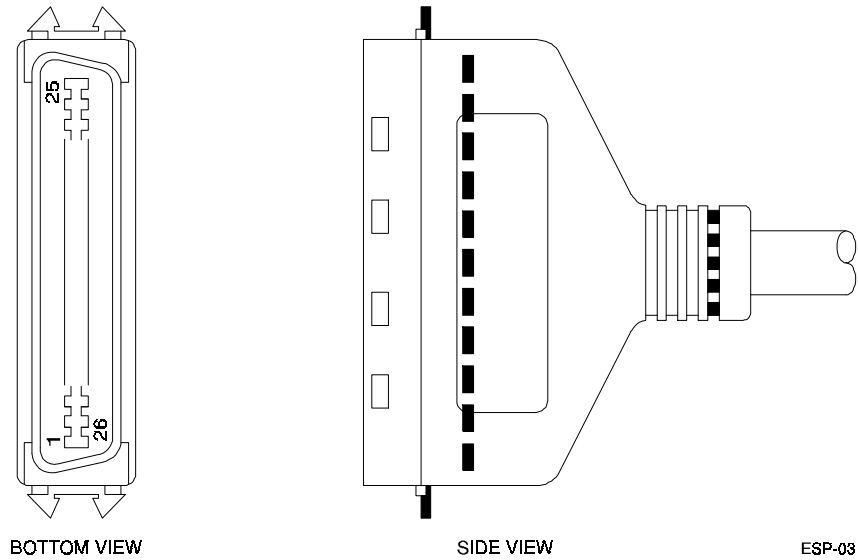

**Figure 2–2 50-Pin High-Density Connector**

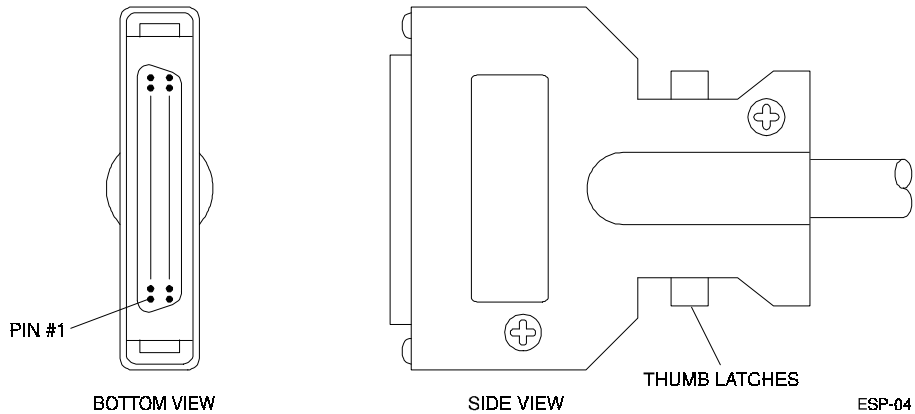

**2.3.2 SCSI Connector Securing Mechanisms**

Table 2–1 describes the various securing mechanisms used with the StorageWorks expansion storage pedestal SCSI connectors.

**Table 2–1 SCSI Connector Securing Mechanisms**

Connector Type	Straight Connector	Right Angle Connector
50-pin, low-density	Bail locks	Not applicable
50-pin, high density	Thumb Latches	Screw fasteners

### 2.3.3 Storage Pedestal SCSI Connectors

The pedestal has a SCSI bus in its backplane that supports the SCSI devices that plug into the slots. The pedestal backplane is preconfigured at the factory with one SCSI bus, but can be reconfigured to support two SCSI buses if desired. Two SCSI connectors are located at the top of the backplane. One is used to connect the pedestal to the host system SCSI bus; the other is used when supporting two buses or extending a SCSI bus from one pedestal to another or to another SCSI device.

### 2.3.4 SCSI "A" Cable

The SCSI "A" cable is designed for 8-bit, single-ended communications. Eight-bit refers to the 8-bit wide data bus; single-ended refers to a single-wire-driven signal on the cable as opposed to a differential wire-pair-driven signal. Table 2–2 describes the three types of SCSI "A" cables used with the pedestal.

**Table 2–2 SCSI "A" Cables**

Cable	Host Connector	Expansion Pedestal Connector
BN21H	50-pin, high-density, male, straight thumb latches.	50-pin, high-density, male, straight thumb latches.
BN21J	50-pin, high-density, male, right angle 2-56 jackscrews.	50-pin, high-density, male, straight thumb latches.
BN23G	50-pin, low-density, male, bail locks.	50-pin, high-density, male, straight thumb latches.

## 2.4 Connecting the Pedestal to the Host System

The pedestal-to-host connection procedure consists of installing the SCSI "A" cable between the pedestal SCSI backplane connector and the SCSI connector on the host system, and then powering on and verifying the visual status of SBB LED indicators to ensure the SCSI connection and the pedestal are operating properly. The information in this section is divided as follows:

- SCSI "A" cable connections
- Power cable connection
- Pedestal power-on test

### 2.4.1 SCSI "A" Cable Connections

Connecting the expansion pedestal to a host system requires the use of one of the SCSI "A" cables listed in Table 2–2. The cable can be routed through the rear of the pedestal behind the bezel, or through one of the four removable filler tabs on each side of the pedestal at your option. Figure 2–3 is a connection diagram showing the SCSI "A" cable connection between the pedestal and the host system. Figures 2–4 and 2–5 show two of the optional routing paths for the SCSI "A" cable. If the shorter three meter cable is used, it may be more convenient to route the SCSI cable from the pedestal to the host directly through one of the upper rear filler tabs on the left or right side of the pedestal depending on the location of your workstation. The following cable routing procedures apply to the longer six meter cable which can be routed through the rear or through one of the filler tabs on each side of the pedestal at your option.

**Figure 2–3 Pedestal-to-Host Connection Diagram**

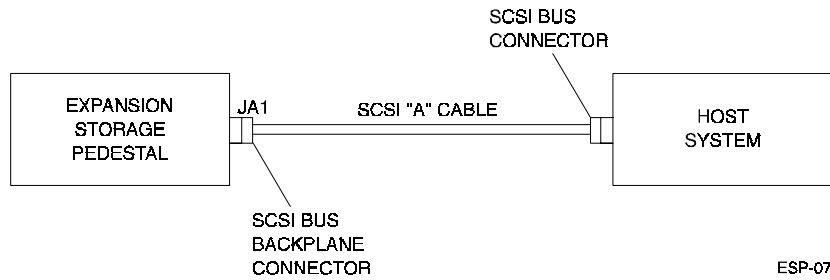

#### 2.4.1.1 Routing SCSI Cable under Rear Bezel (Figure 2–4)

1. Remove both bezels from pedestal as described in Paragraph 4.5.1.
2. Thread one end of straight connector of SCSI "A" cable under rear handle of pedestal base, and through opening at top of pedestal to front of unit.
3. Remove filler panel or SBB from slot 0 of pedestal.
4. Loop SCSI cable down below divider plate and connect cable connector to SCSI connector JA1 (left connector when viewed from front) on backplane of pedestal.
5. Replace SBB or filler panel in slot 0, then replace front and rear bezels as described in Paragraph 4.5.2.
6. Connect other end of SCSI "A" cable to host system.

#### 2.4.1.2 Routing the SCSI Cable through Removable Tab (Figure 2–5)

**NOTE**

The following procedure routes the SCSI "A" cable through the removable filler tab at the right rear of the pedestal. If an alternate path is desired, remove the appropriate tab and follow the same cable path as closely as possible.

1. Remove both bezels from pedestal as described in Paragraph 4.5.1.
2. Feed one end of straight connector of SCSI "A" cable through opening above divider plate to front of pedestal.
3. Remove filler panel or SBB from slot 0 of pedestal.
4. Loop SCSI "A" cable down below divider plate and connect cable connector to connector JA1 (left connector when viewed from front) on backplane.
5. Replace SBB or filler panel in slot 0.
6. Take either bezel and slide out filler tab at lower right corner (as viewed from inside bezel).
7. Route SCSI "A" cable down behind pedestal, then bend cable to left (as viewed from behind pedestal).



8. Take bezel with removed filler tab and install it at rear of pedestal as described in Paragraph 4.5.2, routing SCSI "A" cable through notch created by removed filler tab, then install remaining bezel at front of pedestal.
9. Connect free end of SCSI "A" cable to host system.

**Figure 2-4 Routing SCSI Cable under Rear Bezel**

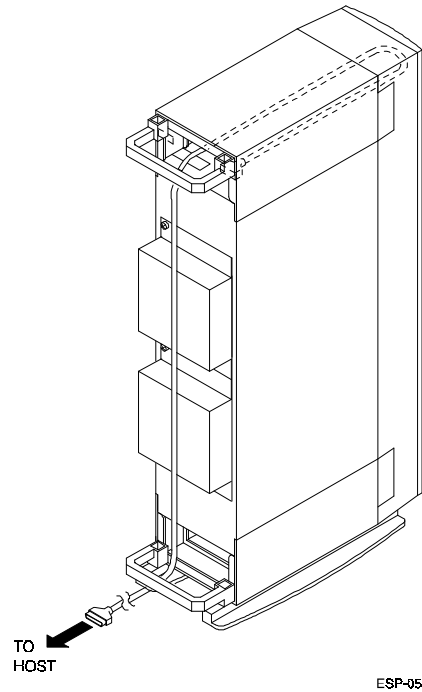

**Figure 2-5 Routing SCSI Cable through Side Filler Panel**

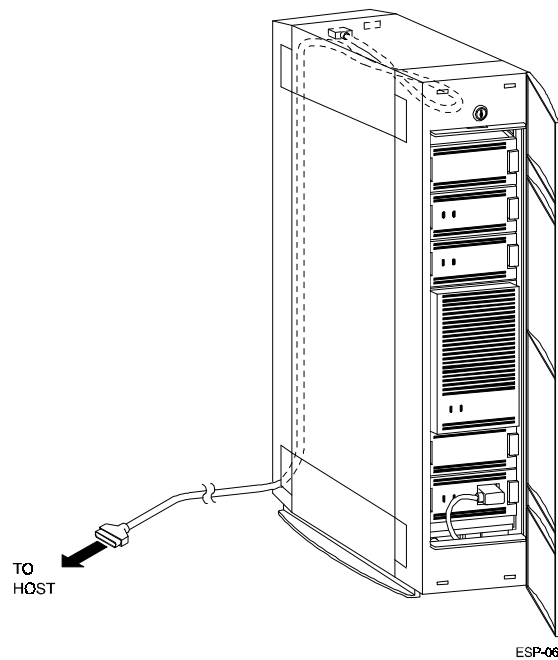

## 2.4.2 Power Cable Connection (Figure 2–6)

The pedestal is equipped with an ac distribution unit that provides switched-controlled ac power to the pedestal power supply. The ac distribution unit also contains a switched ac outlet which can be used to connect a second pedestal ac distribution unit or an optional redundant power supply in the pedestal. In either case, you must install an ac line power cord for connection to 125 or 250 volt line power. Table 2–3 lists the power cords available for the ac distribution unit. Since these power cords are country specific, ensure that your power cord matches those listed in Table 2–3 for your installation.

### NOTE

The ac distribution unit is equipped with three short power plugs, two at the front of the unit and one at the rear. One of the front plugs is connected to the pedestal power supply at the factory. The second front plug is disconnected and available to plug into and power a redundant power supply. The plug at the rear of the distribution unit is disconnected and available to supply power to a second pedestal if desired.

In general, the power cords listed in Table 2–3 have the following characteristics:

- Rated at 10 amps at the specified operating voltage
- 2.5 meters (8.2 feet) in length
- Have a country-specific plug
- Have an IEC 320 C-14 compatible connector

The only exception is the BN27S-03 power cord used in Japan and the United States; it is rated at 15 amps and is three meters (9.8 feet) long.

**Table 2–3 Country-Specific Power Cords**

Country	Voltage	Plug	Length meters (ft.)	Part No,
Australia	250 Vac	AS 3112 - 1981	2.5 (8.2)	BN19H-2E
Central Europe	250 Vac	CEE 7/7 (Schuko)	2.5 (8.2)	BN19C-2E
Denmark	250 Vac	Afsnit	2.5 (8.2)	BN19K-2E
India	250 Vac	BS 546	2.5 (8.2)	BN19S-2E
Ireland	250 Vac	BS 1363	2.5 (8.2)	BN19A-2E
Israel	250 Vac	SI 32	2.5 (8.2)	BN18L-2E
Italy	250 Vac	CEI 213-16/VII	2.5 (8.2)	BN19M-2E
Japan	125 Vac	NEMA 5-15	3.0 (9.8)	BN27S-03 <sup>1</sup>
New Zealand	250 Vac	AS 3112 - 1981	2.5 (8.2)	BN19H-2E
South Africa	250 Vac	BS 546	2.5 (8.2)	BN19S-2E
Switzerland	250 Vac	SEV 1011	2.5 (8.2)	BN19E-2E
United Kingdom	250 Vac	BS 1363	2.5 (8.2)	BN19A-2E
United States	125 Vac	NEMA 5-15	3 (9.8)	BN27S-03 <sup>1</sup>
1. This power cord is rated at 15 amps.				

To connect the power cord to the pedestal refer to Figure 2–6 and proceed as follows:

1. Open the door on the front bezel and ensure the power switch on the ac distribution unit is set to off.
2. Remove the rear bezel as described in Paragraph 4.5.1.
3. Route the female end of the power cord under the handle of the pedestal base and connect the cord to the ac receptacle on the ac distribution unit.
4. Replace the rear bezel as described in Paragraph 4.5.2.
5. Close the door on the rear bezel and connect the other end of the power cord to an ac outlet.
6. If installing SBBs, proceed to Section 2.4.3. If the pedestal is configured as ordered, proceed to the power-on test in Section 2.5.

**Figure 2–6 Power Cable Connection**

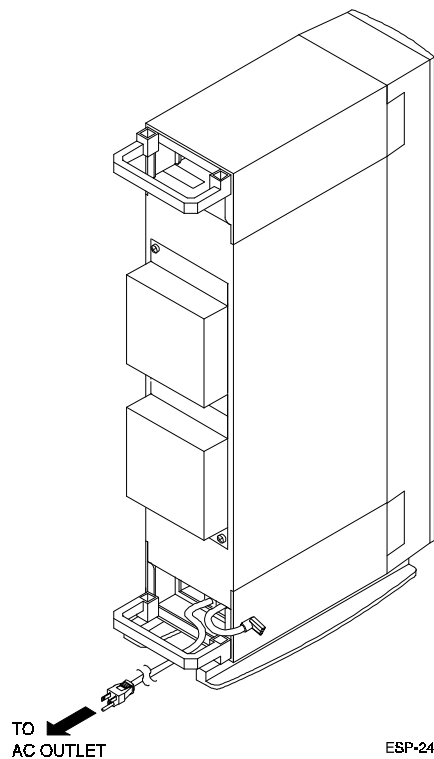

### 2.4.3 Installing Devices

The SBB can be installed with pedestal power on (warm installation) or off (cold installation) at your discretion. Figure 2–7 shows the installation of a 3.5-inch SBB. Since a 5.25-inch SBB requires three pedestal slots, you must remove three adjacent filler panels to install the device. To install an SBB, complete the following procedure:

#### CAUTION

Ensure the SCSI ID address of the device being installed does not conflict with any other devices on the bus.

**NOTE**

If the SBB does not have a SCSI address switch, the SCSI address is the same as the slot number in the pedestal. Refer to Section 3.1.1 for those SBBs that have SCSI switches mounted at the rear of the SBB.

1. Remove the front bezel from the pedestal as described in Paragraph 4.5.1.
2. Remove the filler panel(s) from the desired slot(s) by squeezing the side mounting tabs.
3. Insert the device into the guide grooves and push it in until the tabs lock into place.
4. Set the power switch on the ac distribution unit to on and observe the LEDs on the device to ensure the unit is operating properly (refer to power-on test in Section 2.5 below).
5. After verifying that the device is functioning properly, refer to the procedure in Paragraph 4.5.2 to install the front bezel.

**Figure 2-7 Installing Storage Devices**

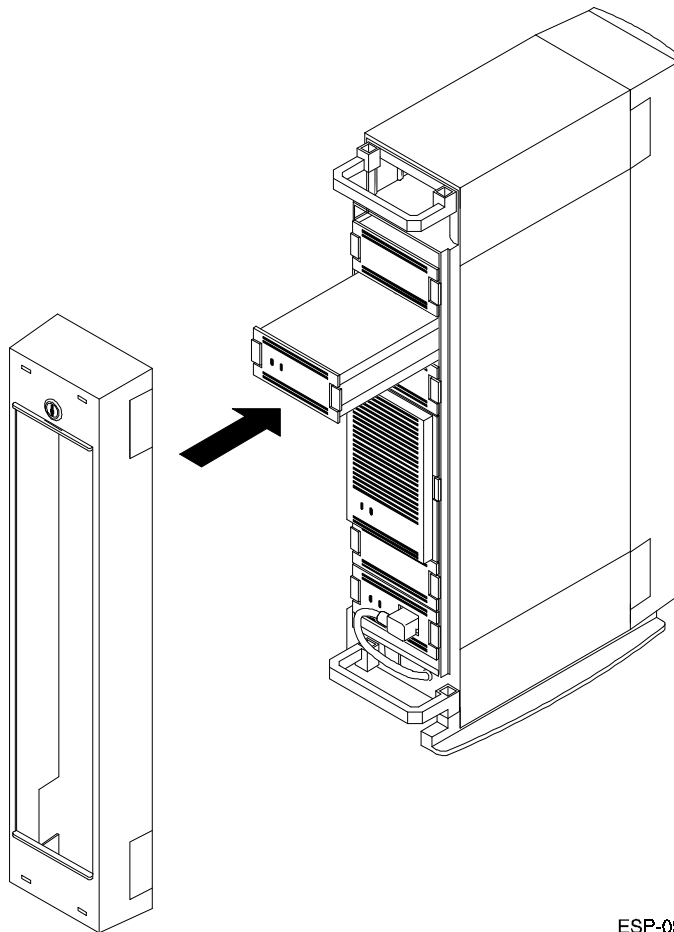

ESP-09

## 2.5 Power-on Test

### CAUTION

Care must be taken when spinning up the drives not to exceed the current capacity of the power supply. It is recommended that the devices spin-up sequentially.

### NOTE

The pedestal SBB LED indicators quickly flash on and off in the following test. **Before powering on the pedestal, read through the procedure to locate the LEDs (Figures 2–8 and 2–9) and familiarize yourself with the normal power-on sequence.** You may power the pedestal on and off to recheck the power-on test if necessary.

1. Verify that the ac power switch on the ac distribution unit (bottom module in the pedestal) is in the off position.
2. Verify that the ac input power and the SCSI cable connections between the pedestal and the host are firmly seated and secure.
3. Turn on the ac power switch on the ac distribution unit and verify the following for each supply:
  - The right LED indicator on all of the power supply SBBs (Figure 2–8) lights first, then both LEDs on the supply remain on
  - All drive SBB activity LEDs (Figure 2–9) initially flash on and then go off

### NOTE

If the drive SBB fault LEDs remain on, this may not necessarily represent a fault condition. It may be necessary to wait until the SBBs have been initialized by the host software.

**Figure 2–8 Power Supply SBB LEDs**

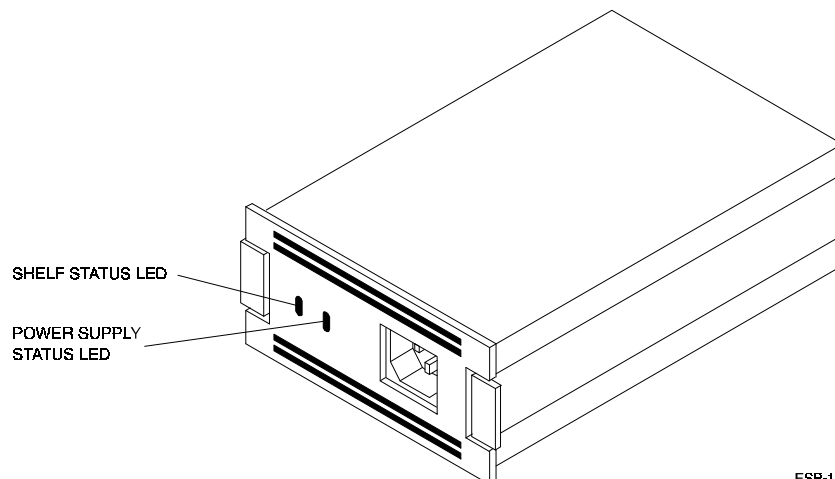

ESP-14

**Figure 2-9 Storage SBB LEDs**

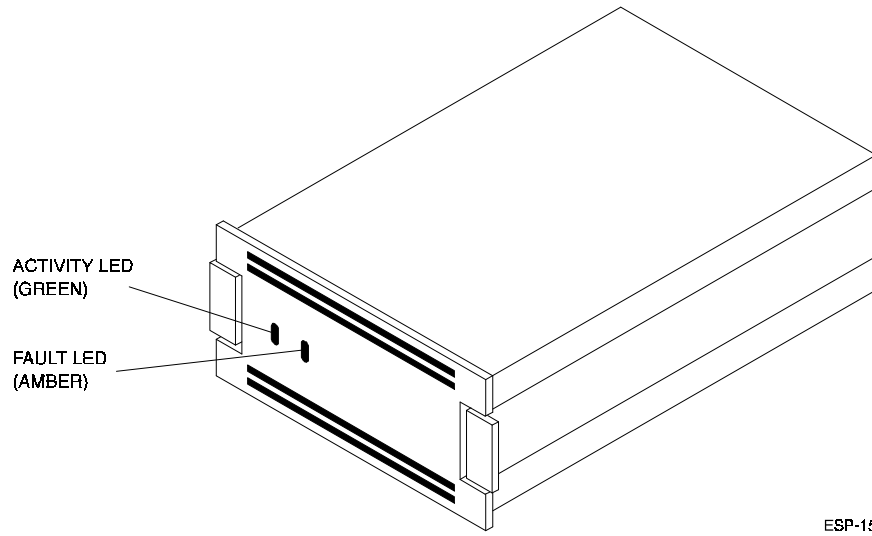

ESP-15

## *Pedestal Configuration Rules*

*This chapter describes the general configuration rules for device addresses, power, SBBs, and the SCSI bus in the pedestal. It also describes how to set the address of 3.5- and 5.25-inch SBBs, how to reconfigure the pedestal from one to two SCSI buses, and how to configure two pedestals for a single SCSI bus.*

### 3.1 Device Addresses

The pedestal is configured at the factory for a single SCSI bus. It may be reconfigured for two SCSI buses if desired (Section 3.4.2). The following rules apply to device addresses for both bus configurations in the pedestal.

- The default SBB addresses are determined by the slot number in the pedestal as viewed from the front as shown in Figure 3–1.
- The available SBB addresses for each slot in the pedestal are 0 through 6.
- The pedestal slot numbers and the ID addresses are the same for 3.5-inch hard drive devices, none of which have address switches.
- The device addresses for 3.5-inch tape drives and 5.25-inch storage devices default to their slot locations in the pedestal when the address switches on the rear of the devices are set to automatic, or can be set manually using the address switches (Section 3.1.1).
- The pedestal power supply slot is always slot 7 and does not have a device address.

**Figure 3–1 Typical StorageWorks Modular Pedestal - Device Addresses**

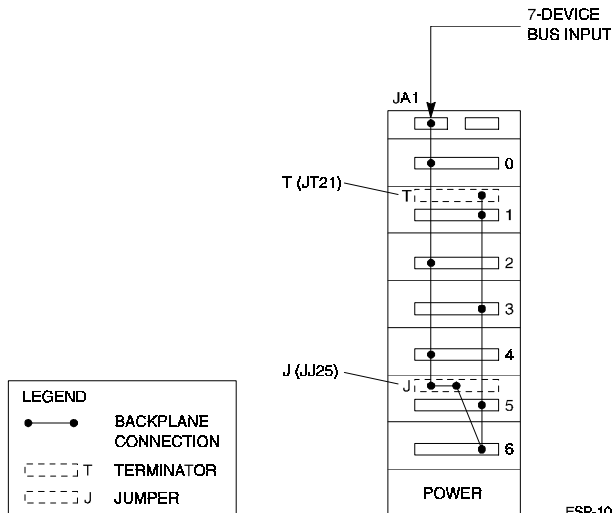

### 3.1.1 Setting the Address of Storage Devices

The address switches on the rear of the 5.25-inch SBBs and 3.5-inch tape drive SBBs (Figure 3–2) are used to override the SBB default device address. Setting these switches to automatic sets the device address to the pedestal's slot number. The switches are preset at the factory to automatic, but can be set manually to a different address at your option. Refer to Table 3–1 to reset the SCSI address as desired.

**Figure 3–2 5.25 and 3.5-inch Device Address Switch Locations**

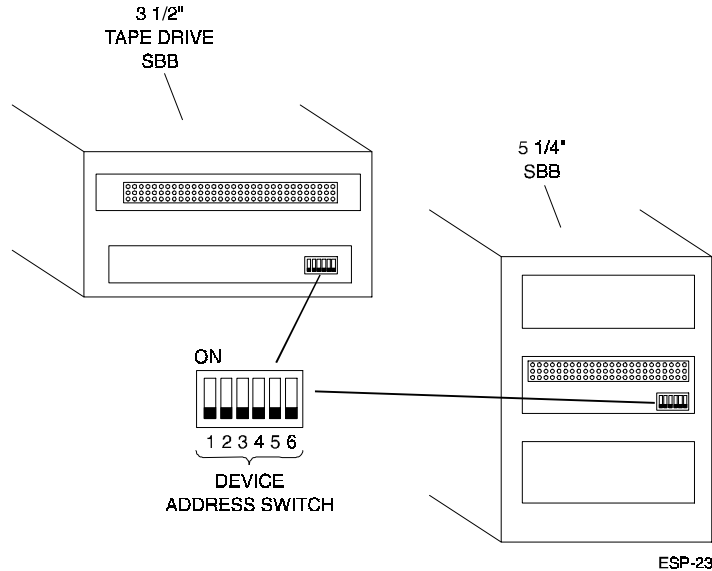

**Table 3–1 Storage Device Address Switch Settings**

Address	SW-1	SW-2	SW-3	SW-4	SW-5	SW-6
0	Off	Off	Off	Off	Off	Off
1	On	Off	Off	Off	Off	Off
2	Off	On	Off	Off	Off	Off
3	On	On	Off	Off	Off	Off
4	Off	Off	On	Off	Off	Off
5	On	Off	On	Off	Off	Off
6	Off	On	On	Off	Off	Off
7*	On	On	On	Off	Off	Off
Automatic†	Off	Off	Off	On	On	On

\* Normally reserved for host.

† Sets device address to pedestal slot number.

## 3.2 Pedestal Power

The following configuration rules apply to the pedestal power supply:

- The pedestal requires an ac input primary power supply mounted in slot 7.
- The pedestal is equipped with an ac distribution unit to provide switched-controlled input voltages to the pedestal power supply(s).



- An optional redundant power supply or an optional battery backup unit (BBU) can only be mounted in slot 6.
- Each power supply can support a maximum of seven 3.5-inch SBBs in slots 0 - 6.

### 3.3 StorageWorks Building Blocks (SBBs)

The following configuration rules apply to the pedestal SBBs:

- Pedestal capacity is measured by the number of 3.5-inch SBBs (Figure 3–3).
- Each 3.5-inch SBB occupies one slot in the pedestal.
- All pedestal power supplies and BBUs are mounted in 3.5-inch carriers.
- A 5.25-inch SBB requires three pedestal slots for mounting (Figure 3–4).
- Some SBB addresses can be controlled by the device address switch on the rear of the device; others automatically default to the pedestal slot number.

**Figure 3–3 Typical 3.5-inch SBB**

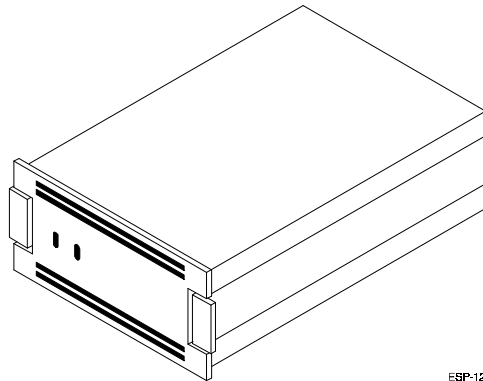

ESP-12

**Figure 3–4 Typical 5.25-inch SBB**

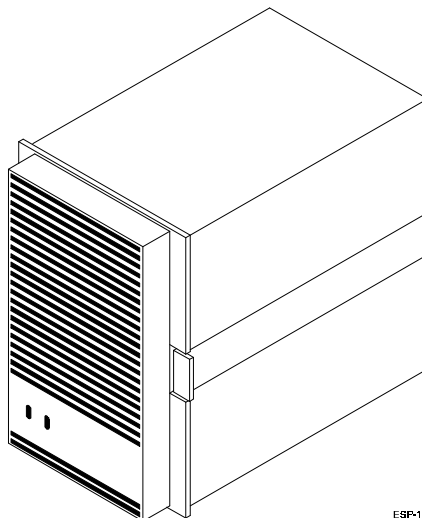

ESP-13

### 3.4 SCSI Bus

The following configuration rules apply to the pedestal SCSI buses:

- The maximum number of storage devices in a pedestal is seven.
- The total length of a fast, single-ended SCSI bus cannot exceed three meters (9.8 feet). This total must include the length of the cable and length of the SCSI bus inside the pedestal (refer to Section 3.4.1 for bus length information).
- The total length of a slow, single-ended SCSI bus cannot exceed 6 meters (19.7 feet).
- A single SCSI bus cannot be daisy-chained for more than two pedestals.
- When configured for two buses, four devices reside on one, and three on the other.
- Each SCSI bus requires a terminator.

#### CAUTION

SCSI buses must be terminated at both ends to ensure proper operation. StorageWorks SBBs cannot terminate a bus.

#### NOTE

The factory installed BA35X-MB active termination board provides proper termination for both a single and a dual SCSI bus configuration (refer to Section 3.4.2 below).

- The BA35XMB terminates the SCSI bus. Do not install an external terminator on JA1 or JB1.
- By convention, the expected target ID addresses are:
  - First host or controller target ID = 7
  - Dual host/controller target ID = 6

#### 3.4.1 SCSI Bus Length Inside the Pedestal

Table 3–2 lists the equivalent lengths of SCSI buses inside the pedestal backplane.

**Table 3–2 SCSI Bus Lengths**

No. of Buses Configured	Meters	Feet
1	0.9	3.3
2	0.5	1.6

#### 3.4.2 Reconfiguring the Pedestal for Two SCSI Buses

The pedestal is preconfigured at the factory for a single SCSI bus. It can be reconfigured for two SCSI buses. To reconfigure the pedestal for two SCSI buses, perform the following procedure. (Refer to Figures 3–5 and 3–6.)

**NOTE**

Refer to Section 2.4.1 for the optional SCSI cable routing paths between the pedestal and the host system.

1. Set the power switch on the ac distribution unit to off.
2. Remove the blowers as described in Chapter 4, Section 4.4.

**NOTE**

An alternative to the following step is to discharge static buildup by momentarily touching a finger to a conducting part of the backplane.

3. Discharge any static buildup by permanently attaching a ground strap between ground and the ac distribution unit.
4. Swap the BA35X-MB terminator board connected to JT21 behind slot 1 with the BA35X-MC jumper board connected to JJ25 behind slot 5.
5. Connect the SCSI "A" cable for devices addresses 0, 2, and 4 to the left connector (JA1) at the front of the backplane in the pedestal.
6. Connect the SCSI "A" cable for device addresses 1, 3, 5, and 6 to the right connector (JB1) at the front of the backplane in the pedestal.
7. Replace the blowers as described in Section 4.4.
8. Reconnect the power cord and power on the pedestal and verify that all devices are active as described in Chapter 2, Section 2.5.

**Figure 3-5 Backplane Configuration for Two SCSI Buses (Front View)**

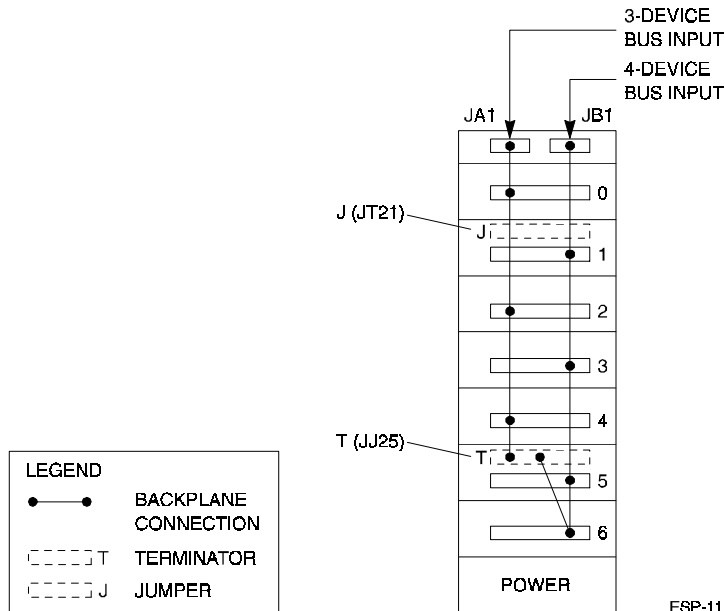

**Figure 3–6 Pedestal-to-Host Connections for Two SCSI Buses**

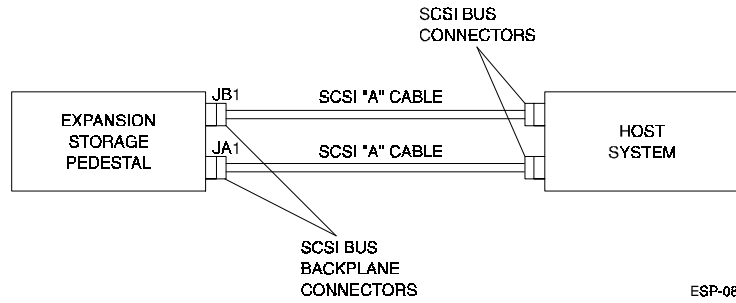

### 3.4.3 Configuring Two Pedestals for a Single SCSI Bus

Two pedestals may be configured to operate as a single SCSI bus to expand your storage requirements. To configure the pedestals on a single SCSI bus (Figure 3–7), perform the following procedure:

**Figure 3–7 Configuring Two Pedestals for a Slow, Single SCSI Bus**

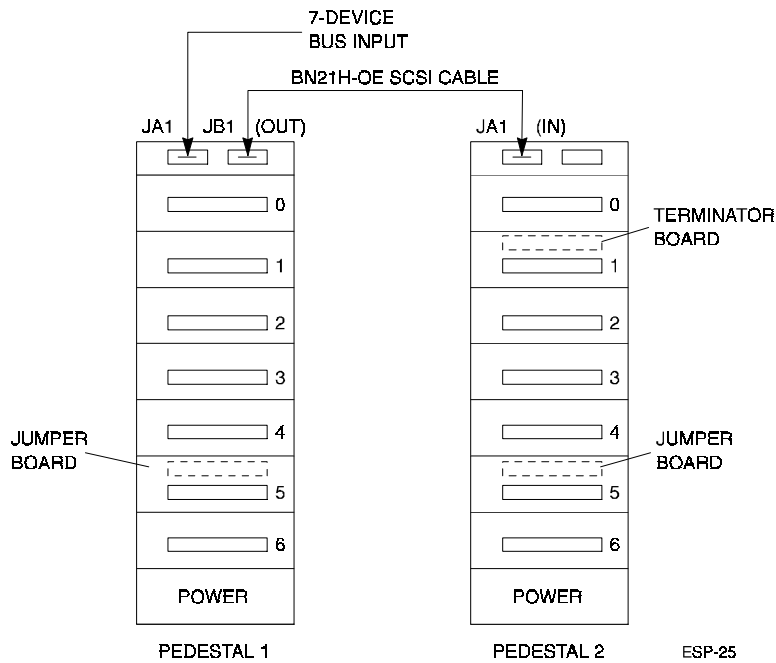

**NOTE**

Although the following procedure describes how to configure two pedestals for a single SCSI bus, the maximum number of pedestals that can be configured on a single bus is determined by the total length of the SCSI bus. This includes the backplane in each pedestal as well as the length of the SCSI cable or cables between the pedestals. For a fast, single-ended bus (10-MB/second transfer rate), the maximum bus length is 3 meters. For a slow, single-ended bus (5-MB/second transfer rate), the maximum bus length is 6 meters. The maximum number of storage devices that can be configured on a single SCSI bus is still seven.

1. Set the two pedestal power switches to off and unplug the ac power.
2. Remove the blowers from each pedestal as described in Chapter 4, Section 4.4.
3. Discharge any static buildup on the pedestals by momentarily touching a finger to a conducting part of the backplane.

**NOTE**

Depending on the specific configuration of your storage subsystem, the installed terminator and/or jumper boards may be pre-configured in the correct backplane locations in the following steps.

4. Install the BA35X-MC jumper board in the backplane connector behind slot 5 in pedestal 1.
5. Remove the BA35X-MB terminator board from the backplane connector behind slot 1 in pedestal 1.
6. Install a BA35X-MC jumper board in the backplane connector behind slot 5 in pedestal 2.
7. Install the BA35X-MB terminator board in the backplane connector behind slot 1 in pedestal 2.
8. Connect a BN21H-OE SCSI cable between pedestal 1 backplane connector JB1 and pedestal 2 backplane connector JA1.
9. Ensure that each installed SBB storage device has a different SCSI bus address.
10. Replace the blowers as described in Section 4.4.
11. Reconnect the power cords, power on the pedestals, and verify that the devices in both pedestals are active and operating as described in Chapter 2, Section 2.2.
12. Refer to the appropriate host bus adapters guide to set the maximum transfer rate to 5 MB/second.

# 4

## *Maintenance*

---

*This chapter describes the status of the SBB LED indicators and how to replace the components in the pedestal. It also presents a brief troubleshooting approach in the event of a pedestal component malfunction.*

---

### **4.1 Pedestal Indicators**

The expansion storage pedestal identifies error conditions or failures caused by the major pedestal components such as the blowers, power supplies, or storage devices. This status is displayed on the power supply and storage device light emitting diodes (LEDs). The following sections describe the logic signals representing these conditions or failures (their states and functions) and how to interpret the LED displays.

#### **4.1.1 Pedestal Status**

The pedestal monitors both cooling and power. The blowers on the rear of the pedestal provide cooling and the pedestal power supply provides +5 Vdc and +12 Vdc to operate the storage devices. The power supply LEDs indicate the state of the pedestal components. The LEDs indicate a fault when one of the following conditions occur:

- A power supply fault
- A blower problem
- An input power problem

#### **4.1.2 Power Supply LEDs**

The status of both the pedestal blowers and the power supplies can be determined by the power supply green LEDs as shown in Figure 4–1. The left LED displays the pedestal (shelf) status and the right LED displays the power supply status.

- When the left LED is on, both the pedestal blowers and the power supplies are functioning properly
- When the left LED is off, either a pedestal blower or a power supply is not functioning properly

Tables 4–1 and 4–2 describe the power supply LED codes.

**Figure 4–1 Power Supply LEDs**

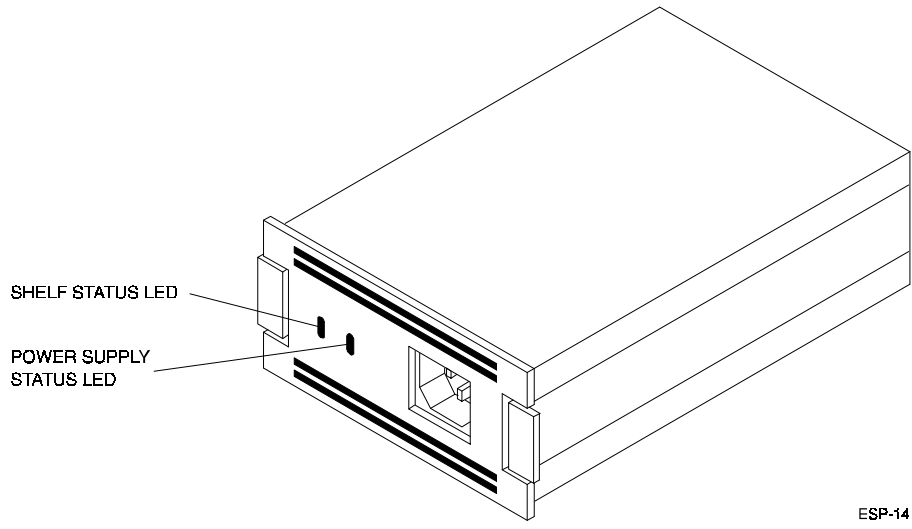

ESP-14

**Table 4–1 Pedestal and Single Power Supply (PS) Status LEDs**

Shelf Status LED	Power Supply Status LED	Indication
On	On	Normal status. Pedestal functioning properly.
Off	On	Bad blower unit. Replace faulty blower.
Off	Off	Power supply bad. Replace faulty supply.

**NOTE**

When the pedestal is equipped with two power supplies, you must observe the LEDs on both power supplies (Table 4–2) to determine the status.

**Table 4–2 Pedestal and Dual Power Supply (PS) Status LEDs**

Shelf Status LED	PS1 LED	Shelf Status LED	PS2 LED	Indication
On	On	On	On	Normal status.
Off	On	Off	On	Blower unit bad. Replace blower.
Off	Off	On	On	PS1 bad. Replace faulty supply.
On	On	Off	Off	PS2 bad. Replace faulty supply.
Off	Off	Off	Off	PS1 and/or PS2 bad. Possible input power problem.

### 4.1.3 Battery Backup Unit LEDs

The LEDs on the battery backup unit (BBU) (shown in Figure 4–2) display the status of the BBU. The LEDs indicate the following:

- The left LED (green) is the BBU charge status LED
- The right LED (amber) is the BBU status LED

**Figure 4–2 BBU LEDs**

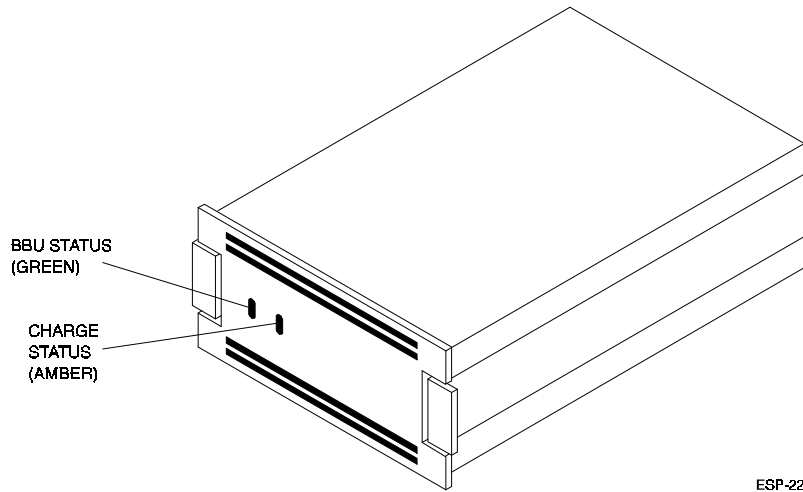

These LEDs are controlled by internal BBU signals. The BBU status is indicated by the LEDs. These LEDs have three states: *on*, *off*, and *flashing*. Table 4–3 describes the valid states for these LEDs.

**Table 4–3 BBU Status LEDs**

BBU Charge LED	BBU Status LED	Indication
On	Off	Normal status, BBU is fully charged and operational.
Off	On	Normal status. BBU is charging.
Off	Flashing	Error status. Power supply failure. BBU in use.
Off	Off	Error status. Either power supply or BBU failure.

### 4.1.4 SBB Status LEDs

Figures 4–3 and 4–4 show the 3.5-inch and 5.25-inch disk drives, respectively. Each drive has two LED indicators that display the status of the device. The status conditions of the LEDs are listed in Table 4–4. The LEDs have three states: *on*, *off*, and *flashing*.

- The left LED (green) is the device activity LED and is on or flashing when the drive is active.
- The right LED (amber) is the drive fault LED and indicates a an error condition when it is either on or flashing



**CAUTION**

Removing an SBB when the left LED is on or flashing can cause the loss or corruption of data.

**Figure 4-3 3.5-inch SBB LEDs**

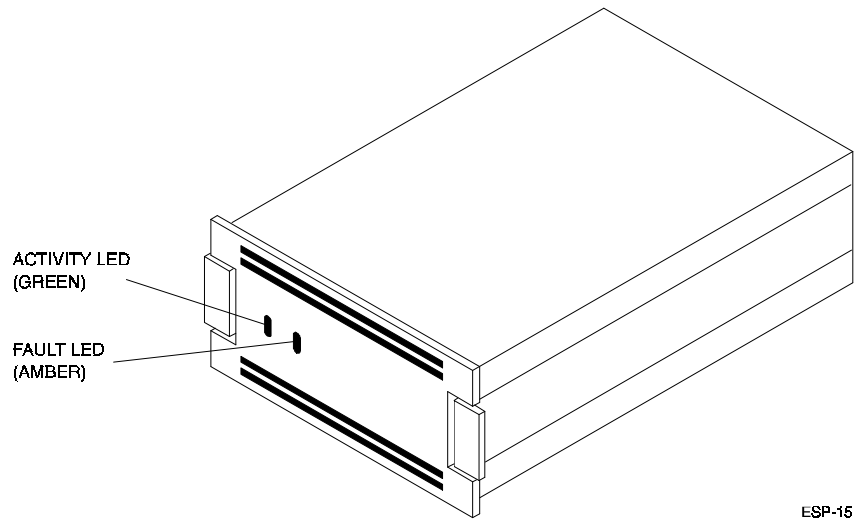

**Figure 4-4 5.25-inch SBB LEDs**

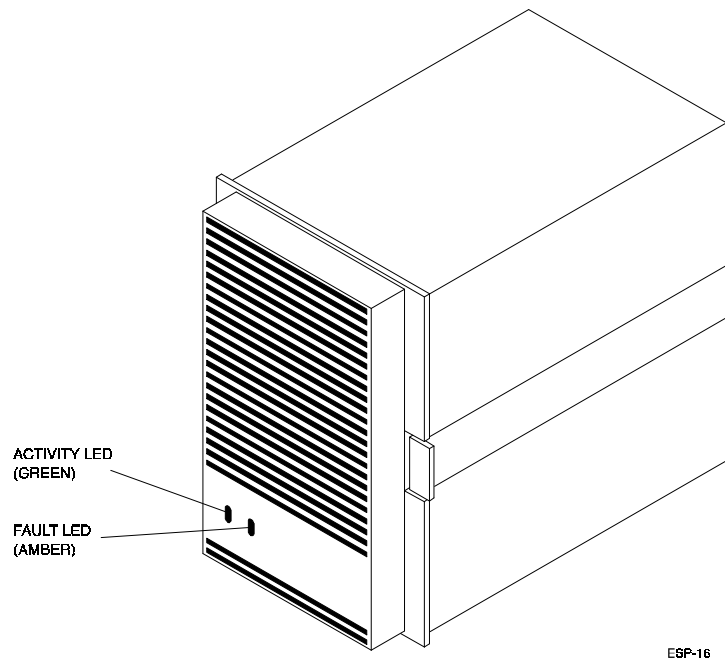

**Table 4–4 SBB Status LEDs**

Activity Status LED	Fault Status LED	Indication
On	Off	Device is operating properly.
Off	Off	Device is inactive and operating normally. There is no fault.
On	On	Fault status, device is hung up. Recommend that you replace the device.
Off	On	Fault status, device is inactive and spun down. Recommend that you replace the device.
On	Flashing	Fault status, device is active and spinning down due to the fault.

## 4.2 Replacing a Storage SBB

### CAUTION

Once a device has been recognized on the SCSI bus by the host, moving the device to another bus or changing the device address can cause problems on the host.

Normally, a storage device is replaced when the device fault indicator is on as defined in Table 4–4. To remove or replace a storage device, perform the following procedure.

### CAUTION

Ensure the replacement SBB is the same type as the one being replaced. Also, always use both hands when handling a device and be careful not to touch the device connector to prevent electrostatic discharge damage.

1. Use the procedure in Paragraph 4.5.1 to remove the front bezel.
2. Press the two locking tabs to release the device, and pull the unit until the rear connector disengages from the backplane connector (approximately one inch). Wait 10 seconds before removing the device from the pedestal to ensure that rotating devices have spun down.
3. Remove the SBB as shown in Figure 4–5.
4. Insert the replacement device into the guide slots and push it in until it is fully seated and the mounting tabs engage the pedestal.
5. After power is applied, observe the status LEDs on the new device. The green device activity LED is either on, flashing, or off, and the amber device fault LED is off.
6. Install the front bezel as explained in Paragraph 4.5.2.

**Figure 4-5 Removing a Storage Device**

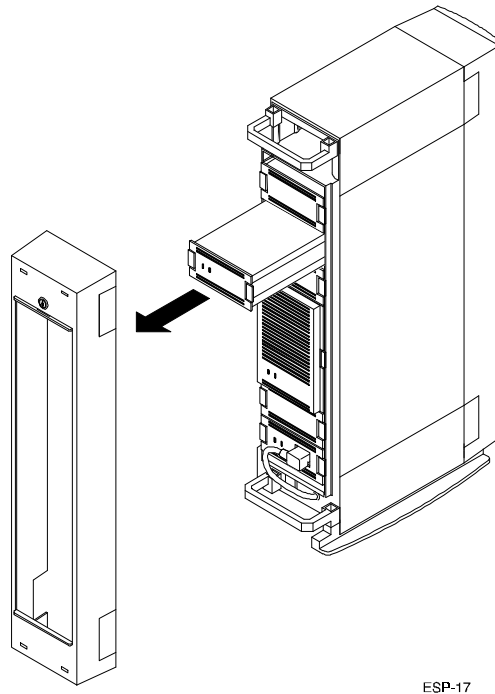

ESP-17

### 4.3 Replacing a Power SBB

You need to replace a power supply or battery backup unit (BBU) when the LEDs indicate a fault condition as outlined in Tables 4-1, 4-2, and 4-3.

The hot-swapping method of replacing a power supply may be used when there are two power supplies. This method allows you to remove the defective power supply while the other power supply furnishes dc power to the pedestal.

The input power for each dc power supply is controlled by a switch on the ac distribution unit. Setting this switch to off removes power from all power supplies in the pedestal. To remove power from a single power supply, simply disconnect the power cable from that power supply and remove the unit.

#### NOTE

The BBU does not provide power for the operation of a storage device. It only provides power for protecting data.

#### 4.3.1 Replacing a Primary Pedestal (Non-Redundant) Power Supply

Perform the following procedure to replace a pedestal primary power supply:

1. Power down the pedestal by setting the power switch on the ac distribution to *off* and remove the input power cable from the power supply.
2. Remove the front bezel using the procedure in Paragraph 4.5.1.

3. Press the two locking tabs to release the unit, and slide it out of the pedestal (similar to replacing a drive as shown in Figure 4–5).
4. Insert the replacement supply into the guide slots and push it in until the tabs lock into place.
5. Reconnect the input power cable to the power supply and turn the power switch on the ac distribution to on.
6. Observe the LEDs and ensure the power supply is functioning properly (refer to Tables 4–1 and 4–2). Observe the LEDs on both the power supply and the storage devices for normal operating indications.
7. Install the front bezel using the procedure in Paragraph 4.5.2.

### **4.3.2 Replacing a Redundant Power Supply**

Perform the following procedure to replace a pedestal redundant power supply:

1. Remove the front bezel using the procedure in Paragraph 4.5.1.
2. Press the two locking tabs to release the unit, and slide it out of the pedestal (similar to replacing a drive as shown in Figure 4–5).
3. Insert the replacement redundant supply into the guide slots and push it in until the tabs lock into place.
4. Reconnect the input power cable to the redundant power supply and turn the power switch on the ac distribution to on.
5. Observe the LEDs and ensure the power supply is functioning properly (refer to Tables 4–1 and 4–2). Observe the LEDs on both the power supply and the storage devices for normal operating indications.
6. Install the front bezel using the procedure in Paragraph 4.5.2.

### **4.3.3 Replacing a Pedestal BBU**

To replace a BBU in slot 6, perform the following procedure:

1. Remove the front bezel using the procedure in Paragraph 4.5.1.
2. Press the two locking tabs to release the unit, and slide it out of the pedestal (similar to replacing a drive as shown in Figure 4–5).
3. Insert the replacement unit into the guide slots and push it in until the tabs lock into place.
4. Observe the LEDs and ensure the BBU is charging as specified in Table 4–3. The BBU should be fully charged in approximately one hour.
5. Install the front bezel using the procedure in Paragraph 4.5.2.

## 4.4 Replacing a Fan Assembly (Blower)

### WARNING

Due to hazardous high-current energy levels present in the backplane area, use extreme caution while swapping blowers in the following procedure. Keep all metal objects, including rings and jewelry, out of the blower/backplane cavity.

### CAUTION

To prevent an overheating condition, the replacement blower should be readily available to immediately replace the faulty blower during the following procedure.

The pedestal has two blowers mounted at the rear. Connectors on the backplane provide the +12 Volts dc to operate the blowers. As long as one blower is operational, there is sufficient airflow to prevent an overheating condition. When either blower fails, the left shelf status LED on the power supply goes off (refer to Table 4–1). When a blower is removed, the change in the airflow pattern reduces the cooling to the point that the pedestal can overheat in 60 seconds. Figure 4–6 shows the removal of a blower.

To replace a blower, perform the following procedure:

1. Determine which of the two blowers has failed by feeling the air flow at the bottom of each blower.
2. Remove the rear bezel using the procedure in Paragraph 4.5.1.
3. Using a Phillips screwdriver, remove the safety screw in the corner of the blower.
4. Press the side locking tabs to release the blower.
5. Pull the blower straight out to disconnect it from the pedestal power connector.
6. Align the replacement blower connector and insert the module straight in, making sure that both locking tabs are firmly seated in the pedestal.
7. Replace the safety screw in the corner of the blower.
8. Verify that the pedestal and all SBBs are operating properly (refer to pedestal status, Tables 4–1 and 4–2).
9. Install the rear bezel using the procedure in Paragraph 4.5.2.

### NOTE

If the left power supply LED (pedestal status) does not come on and all the pedestal power supplies are operating, the second blower may have failed or the wrong blower was replaced.

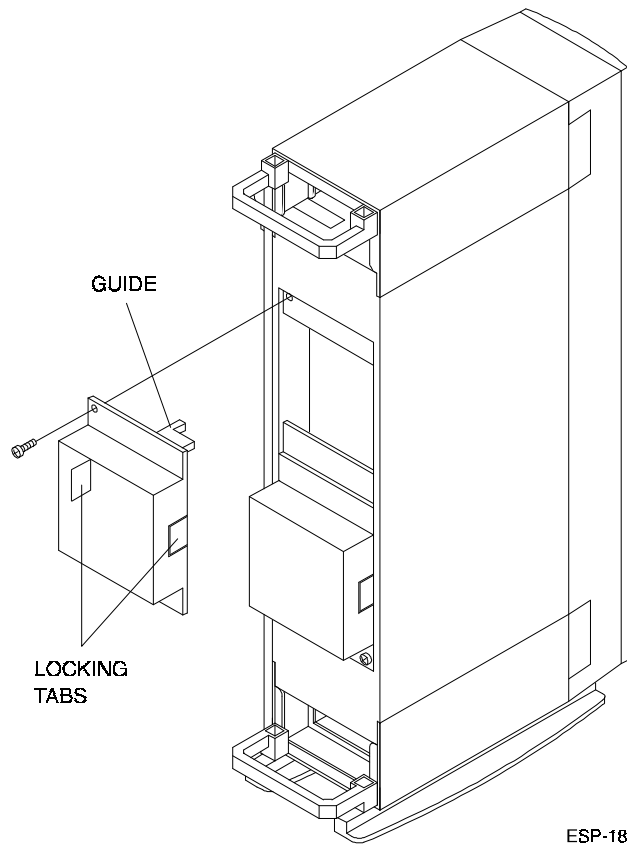
**Figure 4–6 Removing a Blower**

## 4.5 Remove/Install Front/Rear Bezel

The front and rear bezels are identical and interchangeable.

### 4.5.1 Remove Front/Rear Bezel

To remove a front or rear bezel, refer to Figure 4–7 and proceed as follows:

1. Open front door of bezel.
2. Unlock bezel with key supplied, then store key in secure place.
3. Pull top of bezel forward off pedestal.
4. Push bezel down slightly to disengage tabs securing bezel to base of pedestal.
5. Remove bezel from pedestal.

**Figure 4-7 Removing Front/Rear Bezel**

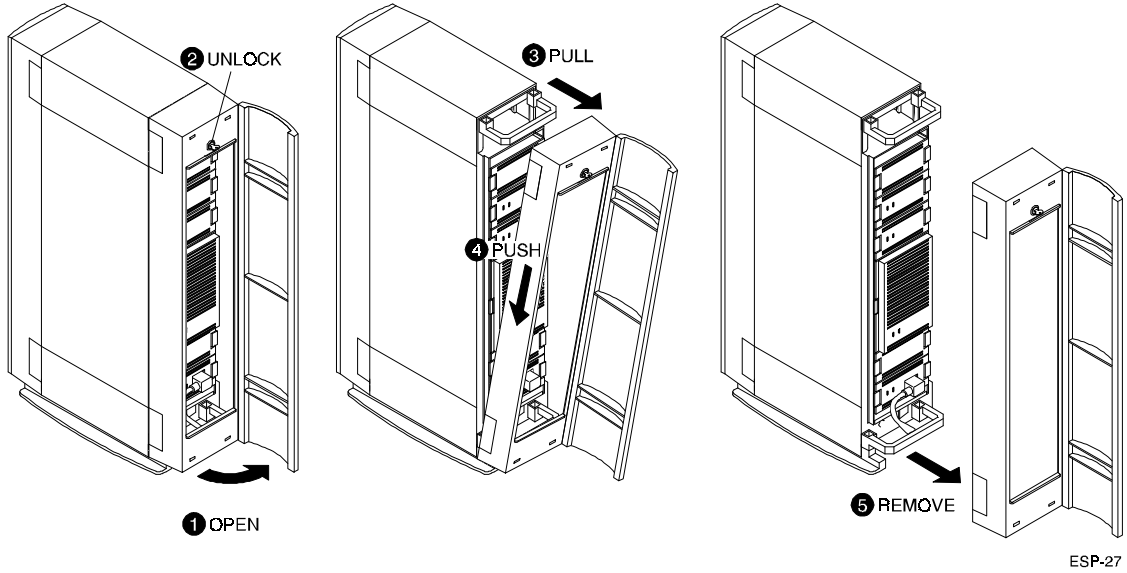

#### 4.5.2 Install Front/Rear Bezel

To install a bezel at the front or rear of the pedestal, refer to Figure 4-8 and proceed as follows:

1. With bezel door open, engage tabs at base of bezel under pedestal.
2. Push top of bezel forward until it fits evenly over pedestal.
3. Lock bezel in place and remove key. Store key in secure place.
4. Close bezel door.

**Figure 4-8 Installing Front/Rear Bezel**

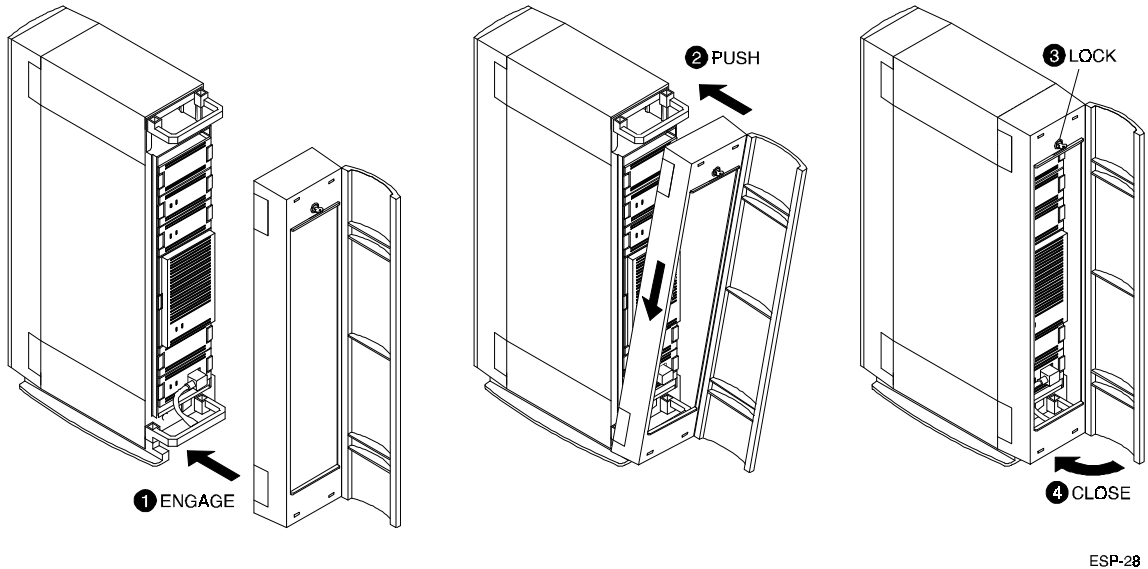

## 4.6 Troubleshooting the Pedestal

The primary troubleshooting tool in analyzing problems in the pedestal is the status of the storage device carriers LED indicators as described in Tables 4–1 through 4–4 above. If a disk drive amber LED is on, check the host system error log to pinpoint device errors. Also, unplug the faulty device and try reseating the unit to ensure a proper connection with the pedestal backplane slot connector.



# 5

## Illustrated Parts

This chapter contains an illustrated breakdown of the field replaceable parts in the StorageWorks Expansion Storage Pedestal. The information consists of an exploded view of the pedestal and its associated part numbers and item descriptions.

Figure 5-1 Pedestal Field Replaceable Parts

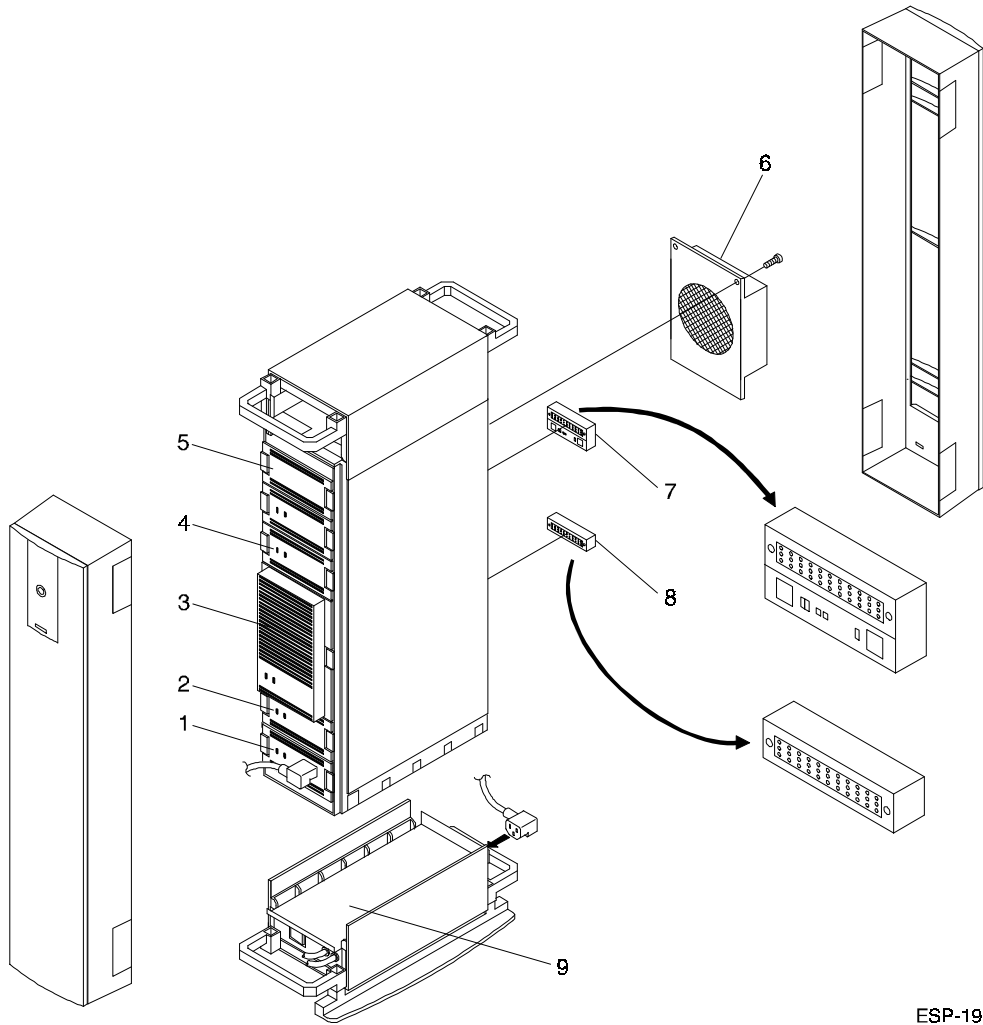

ESP-19

**Table 5–1 Pedestal Field Replaceable Parts (Refer to Figure 5–1)**

<b>Item</b>	<b>Part Number</b>	<b>Description</b>
1	SWXBP-SA	131 W universal AC power supply
1	SWXBP-SD	150 W AC power supply
2	SWXBP-SC	Battery Backup Unit (BBU)
3	SWxx5-xx	5.25-inch disk drive
4	SWxx3-xx	3.5-inch disk drive
5	BA35X-PA	3.5-inch filler panel
6	BA35X-MA	Fan carrier (blower) assembly
7	BA35X-MB	SCSI backplane active terminator board
8	BA35X-MC	SCSI backplane jumper board*
9	70-29914-01	AC distribution unit

\* Part number located on back of part.



# StorageWorks Product Specifications

---

*This appendix describes the physical and environmental specifications for the StorageWorks Expansion Storage Pedestal.*

---

## A.1 Input Power Requirements

The input power requirements for a StorageWorks enclosure are determined by the number and type of Power Units and StorageWorks Building Block (SBB) devices.

## A.2 Power Units

Each StorageWorks enclosure requires an ac or dc power unit. The power unit type is determined by the enclosure power system, either ac or -48 Vdc.

The enclosure can have a redundant power unit to ensure that a power unit failure does not disable the unit. In most cases, battery backup units (BBUs) can be combined with the pedestal power unit to provide extended system data integrity. See the following table for more information about the power units.

Table A-1 contains the specifications for the SWXBP-SA, SWXBP-SC, and SWXBP-SD StorageWorks power units.

**Table A-1 StorageWorks Power Units**

Specifications	SWXBP-SA	SWXBP-SC	SWXBP-SD
Power unit type	AC input	Battery backup	AC input
Input voltage range	90–264 Vac	N/A	90–264 Vac
Nominal input voltage	110 Vac	12 Vdc‡	110 Vac
Autoranging feature	Yes	No	Yes
Output voltages	12 Vdc 5 Vdc	12 Vdc 5 Vdc	12 Vdc 5 Vdc
Output power†	131 W	200 W peak power for 16, 32, or 64 seconds	150W

† Sequential device spin-up at 4-second interval mandatory

‡ Charging voltage

### A.3 Physical Specifications

Table A–2 lists the physical specifications of the StorageWorks Expansion Storage Pedestal and StorageWorks Building Blocks (SBBs).

**NOTE**

The depth specifications in Table A–2 do not include the service area requirements, which are as follows:

- Deskside expansion enclosures are portable and should be positioned to provide a front or rear service area of 762 millimeters (30 inches)

**Table A–2 StorageWorks Expansion Storage Pedestal Physical Specifications**

Description	Height mm (in)	Width mm (in)	Depth mm (in)
<b>StorageWorks Enclosures</b>			
Deskside expansion enclosure	578 (22.75)	203 (8.0)	400 (15.75)
<b>StorageWorks Building Blocks</b>			
3½-inch SBB	121 (4.8)	51 (2.0)	216 (8.5)
5¼-inch SBB	121 (4.8)	152 (6.0)	267 (10.5)

## A.4 Environmental Specifications

The StorageWorks product line environmental specifications listed in Table A–3 are the same as for other Digital storage devices.

**Table A–3 Environmental Specifications**

Condition	Specification
<b>Optimum Operating Environment</b>	
Temperature	+18° to +24° C (+65° to +75° F)
Rate of change	3° C (5.4° F)
Step change	3° C (5.4° F)
Relative humidity	40% to 60% (non condensing) with a step change of 10% or less (non condensing)
Altitude	From sea level to 2400 m (8000 ft)
Air quality	Maximum particle count 0.5 micron or larger, not to exceed 500 ,000 particles per cubic ft of air
Inlet air volume	0.026 cubic m per second (50 cubic ft per minute)
<b>Maximum Operating Environment (Range)</b>	
Temperature	+10° to +35° C (+50° to +95° F) Debate 1.8° C for each 1000 m (1.0° F for each 1000 ft) of altitude Maximum temperature gradient 11° C/hr (20° F/hr) ± 2° C/hr (4° F/hr)
Relative humidity	10% to 90% (non condensing) Maximum wet bulb temperature: 28° C (82° F) Minimum dew point: 2° C (36° F)
<b>Maximum Nonoperating or Storage Environment (Range)</b>	
Temperature	
Non operating	+18° to +29° C (+65° to +85° F)
Storage	-40° to +66° C (-40° to +151° F)
Relative humidity	
Non operating	10% to 90% (non condensing)
Storage	8% to 95% in original shipping container (non condensing); otherwise, 50% (non condensing)
Altitude	From -300 m (-1000 ft) to +3600 m (+12,000 ft) MSL

## A.5 Environmental Stabilization

To ensure proper operation of Digital storage devices, the SBB temperature must be within 18–29° C (65–85° F). Table A–4 specifies the time required to thermally stabilize SBBs based on the ambient shipping temperature.

### CAUTION

Always stabilize storage devices in the operating environment prior to installation or operation. Otherwise, the media or associated electronics may be damaged when power is applied to the unit.

#### If condensation is visible on the outside of the storage device:

Stabilize the device and the SBB in the operating environment for 6 hours or until the condensation is no longer visible, whichever is longer. Do not insert the storage device into the pedestal until it is fully stabilized.

#### If condensation is not visible on the outside of the storage device:

Thermally stabilize the device for the amount of time specified in Table A–4.

**Table A–4 Thermal Stabilization Specifications**

Ambient Temp. Range ° C	Ambient Temp. Range ° F	Minimum Stabilization Time
60 to 66	140 to 151	3 hours
50 to 59	122 to 139	2 hours
40 to 49	104 to 121	1 hour
30 to 39	86 to 103	30 minutes
18 to 29	65 to 85	None
10 to 17	50 to 64	30 minutes
0 to 9	32 to 49	1 hour
-10 to -1	14 to 31	2 hours
-20 to -11	-4 to 13	3 hours
-30 to -21	-22 to -5	4 hours
-40 to -31	-40 to -21	5 hours



## *Manufacturer's Declarations*

---

*This appendix contains the Radio Frequency Interference (RFI) and acoustic noise declarations for the expansion storage pedestal.*

---

### **NOTE**

The following statements are applicable to the StorageWorks Expansion Storage Pedestal.

This equipment generates, uses, and may emit radio frequency energy. The equipment has been type tested and found to comply with the limits for a Class B digital device pursuant to Part 15 of the FCC rules. These limits are designed to provide reasonable protection against harmful interference in a residential installation.

Any changes or modifications made to this equipment may void the user's authority to operate the equipment.

Operation of this equipment in a residential area may cause interference in which case the user, at his own expense, will be required to take whatever measures may be required to correct the interference.

### **CAUTION**

This is a Class B product. In a domestic environment, this product may cause radio interference, in which case the user may be required to take adequate measures.

### **ACHTUNG !**

Dieses ist ein Gerät der Funkstörgrenzwertklasse B. In Wohnbereichen können bei Betrieb dieses Gerätes Rundfunkstörungen auftreten, in welchen Fällen die Benutzer für entsprechende Gegenmaßnahmen verantwortlich sind.

### **ATTENTION !**

Ceci est un produit de Classe B. Dans un environnement domestique, ce produit risque de créer des interférences radiélectriques, il appartiendra alors à l'utilisateur de prendre les mesures spécifiques appropriées.

## Acoustic Noise Declaration

## BA350--SA (SWXSE-02) StorageWorks Expansion Storage Pedestal

February 1, 1993

## Acoustics – Preliminary Declared Values per ISO 9296 and ISO 7779

Product†	Sound Power Level $L_{WA}$ , B‡		Sound Pressure Level $L_{pAm}$ , dBA (Bystander Positions)	
	Idle	Operate	Idle	Operate
SWXSE-02 SBB Pedestal	5.8	5.8	41	41
SWXSE-02 SBB Pedestal with: Seven Disk Drives	5.9	5.9	41	41
<b>Deskside Expansion Enclosure (at the side of the desk)</b>				
SWXSE-02 SBB Pedestal	5.7	5.7	40	40
SWXSE-02 SBB Pedestal with: Seven Disk Drives	5.8	5.8	40	40
Product†	Sound Power Level $L_{WA}$ , B‡		Sound Pressure Level $L_{pAm}$ , dBA (Operator Positions)	
	Idle	Operate	Idle	Operate
<b>Deskside Expansion Enclosure (at the side of the desk)</b>				
SWXSE-02 SBB Pedestal	5.7	5.7	37	37
SWXSE-02 SBB Pedestal with: Seven Disk Drives	5.8	5.8	37	37
<b>Deskside Expansion Enclosure (on top of the desk)</b>				
SWXSE-02 SBB Pedestal	5.7	5.7	48	48
SWXSE-02 SBB Pedestal with: Seven Disk Drives	5.8	5.8	48	48

†Current values for specific configurations are available from Digital Account Representatives.  
‡1 B = 10 dBA



## Acoustic Noise Declaration

### BA350--SA (SWXSE-02) StorageWorks Expansion Storage Pedestal

February 1, 1993

#### Schallemissionswerte – Vorläufige Werteangaben nach ISO 9296 und ISO 7779/DIN EN27779

Gerät†	Schalleistungspegel $L_{WA}$ B‡		Schalldruckpegel $L_{pAm}$ dBA (Beistehende Position))	
	Leerlauf	Betrieb	Leerlauf	Betrieb
SWXSE-02 SBB Pedestal	5,8	5,8	41	41
SWXSE-02 SBB Pedestal mit: 7 Disk Drives	5,9	5,9	41	41
<b>Deskside Expansion Enclosure neben einem Schreibtisch</b>				
SWXSE-02 SBB Pedestal	5,7	5,7	40	40
SWXSE-02 SBB Pedestal mit: 7 Disk Drives	5,8	5,8	41	41
<b>Deskside Expansion Enclosure neben einem Schreibtisch</b>				
Gerät†	Schalleistungspegel $L_{WA}$ B‡		Schalldruckpegel $L_{pAm}$ dBA (Belener Position))	
	Leerlauf	Betrieb	Leerlauf	Betrieb
<b>Deskside Expansion Enclosure neben einem Schreibtisch</b>				
SWXSE-02 SBB Pedestal	5,7	5,7	37	37
SWXSE-02 SBB Pedestal mit: 7 Disk Drives	5,8	5,8	37	37
<b>Deskside Expansion Enclosure auf einem Schreibtisch</b>				
SWXSE-02 SBB Pedestal	5,7	5,7	48	48
SWXSE-02 SBB Pedestal mit: 7 Disk Drives	5,8	5,8	48	48
† Aktuelle Werte für spezielle Ausrüstungsstufen sind über die Digital Equipment Vertretungen erhältlich..				
‡ 1 B = 10 dBA				

Für Bundesrepublik Deutschland  
For Federal Republic of Germany  
Pour la République fédérale d'Allemagne

Hochfrequenzgerätezulassung und Betriebsgenehmigung

Bescheinigung des Herstellers/Importeurs:

Hermit wird bescheinigt, daßdie Einrichtung in Übereinstimmung mit den Bestimmungen der DBP-Verfügung 523/1969, Amtsblatt 113/1969, und Grenzwertklasse "A" der VDE0871 funkentstört ist.

Das Bundesamt für Zulassungen in der Telekommunikation der Deutschen Bundespost (DBP) hat diesem Gerät eine FTZ-Serienprüfnummer zugeteilt.

Betriebsgenehmigung:

Hochfrequenzgeräte dürfen erst in Betrieb genommen werden, nachdem hierfür von dem für den vorgesehenen Aufstellungsort zuständigen Fernmeldeamt mit Funkstörungenmeßstelle die Genehmigung erteilt ist.

Als Antrag auf Erteilung einer Genehmigung dient eine meldepostkarte (Anhang des Handbuches) mit Angabe der FTZ-Serienprüfnummer.

Der untere Teil der Postkarte ist vom Betreiber zu vervollständigen und an das örtliche Fernmeldeamt zu schicken. Der obere Teil bleibt beim Gerät.

Betreiberhinweis:

Das Gerät wurde funktechnisch sorgfältig entstört und geprüft. Die Kennzeichnung mit der Zulassungsnummer bietet Ihnen die Gewähr, daßdieses Gerät keine anderen Fernmeldeanlagen einschließlich Funkanlagen stört. Sollten bei diesen Geräten ausnahmsweise trotzdem, z.B. im ungünstigsten Fall beim Zusammenschalten mit anderen EVA-Geräten, Funkstörungen auftreten, kann das im Einzelnen zusätzliche Funkentstörungsmaßnahmen durch den Benutzer erfordern.

Bei Fragen hierzu wenden Sie sich bitte an die örtlich zuständige Funkstörungenmeßstelle Ihres Fernmeldeamtes.

Externe Datenkabel:

Sollte ein Austausch der von Digital spezifizierten Datenkabel nötig werden, muß derr BBetreiber für eine einwandfreie Funkentstörung sicherstellen, daßf Austausch kabel im Aufbau und Abschirmqualität dem Digital Originalkabel entsprechen

Kennzeichnung:

Die Geräte werden bereits in der Fertigung mit der Zulassungsnummer gekennzeichnet und mit einer Anmeldepostkarte versehen. Sollte Kennzeichnung und Anmeldepostkarte übergangsweise nicht mit ausgeliefert werden, kontaktieren Sie bitte das nächstgelegene Digital Equipment Kundendienstbüro.

# *Glossary*

---

*This Glossary provides definitions of commonly used terms in the Expansion Storage Pedestal User's Guide.*

---

## **ac distribution**

The method of routing ac power in the pedestal.

## **Battery Backup Unit (BBU)**

StorageWorks power unit option that extends power availability after the loss of primary ac power or a power unit, to protect against the corruption or loss of data.

## **cold swap**

A method of device replacement that requires that power be removed from the pedestal thereby affecting other devices therein. User applications that are dependent on the devices being swapped are impacted as a result. This method is used when conditions preclude the use of a hot-swap method. Normally, this method is only used when installing or upgrading a StorageWorks subsystem.

## **disk**

A storage device supporting random access to fixed sized blocks of data.

## **host**

The primary or controlling computer (or any such computer in a multiple computer network) to which storage is attached.

## **hot-swap**

A method of device replacement whereby the complete system remains on-line during device removal or insertion. Activity may be suspended for a brief period during device insertion or removal.

## **SBB**

StorageWorks building block. The basic building block of the StorageWorks product line. Any device conforming to pedestal mechanical and electrical standards, installed in either a 3.5-inch or 5.25-inch carrier, is considered an SBB, whether it is a storage device, power supply, CPU, or other device.

## **SCSI**

Small Computer System Interface. This ANSI interface defines the physical and electrical parameters of a parallel I/O bus used to connect computers and devices. The StorageWorks pedestal implementation uses SCSI-2 for the synchronous transfer of 8-bit data at rates equal to, or greater than, 10 MB/s, and the synchronous transfer of 16-bit data at rates equal to, or greater than, 20 MB/s.

## **Small Computer System Interface**

See *SCSI*.

## **storage array**

An integrated set of storage devices.

## **supported device**

(1) A device that has been fully evaluated in an approved StorageWorks configuration, (pedestal, power supply, cabling, etc.) and is in complete compliance with country-specific standards (for example: FCC, TUV, etc.) and with all Digital standards. (2) A device supported by a controller or host operating system.

## **tape**

A storage device supporting sequential access to variable sized data records.

## **A**

ac distribution unit, 1–4  
address switch location, 3–2  
avoiding electrical shock, 4–8  
avoiding overheating condition, 4–8

## **B**

battery backup unit (BBU), 1–1, 1–4, 3–3, 4–3  
BBU *see Battery Backup Unit*  
bezel removal, 4–9, 4–10  
Blower Unit, 1–3

## **C**

configuration rules, 3–1  
configuring two pedestals for a single SCSI bus,  
3–6  
connecting pedestal to host system, 2–3  
country-specific power cords, 2–6

## **D**

device addresses, 3–1  
drive, 3.5-inch, 1–1  
drive, 5.25-inch, 1–1

## **E**

electrical shock risks, 4–8  
error conditions, 4–1, 4–2, 4–3, 4–5, 4–11  
expansion storage pedestal components typical  
configuration (figure), 1–3  
expansion storage pedestal configuration  
(figure), 1–1

## **F**

filler panels removal, 2–4  
front/rear bezel removal *see bezel removal*

## **G**

guide, 1–2

## **H**

high-density female SCSI connectors, 2–1

## **I**

input SCSI connector, 2–4  
installation of SBBs 2–7  
installation procedure, 2–3  
installing devices in pedestal, 2–7

## **L**

LEDs, 1–2  
LED display  
pedestal status, 4–1  
power supply status., 4–1  
LED power-on sequence, 2–9  
LED states, 4–3

## **M**

maintenance, 4–1  
modular storage cabinet, 1–3  
mounting tabs, 1–3

## **O**

output SCSI connector, 3–6

## **P**

packing slips, 2–1  
pedestal  
basic features, 1–2  
capacity, 1–3

- description, 1–2
- slots, 1–3
- unpacking, 2–1
- connector, 1–2
- features, 1–2
- indicators, 4–1
- power, 3–2
- power supply status LEDs, 4–2
- product line, 1–1
- slots, 1–3
- status, 4–1

pedestal-to-host connection (diagram), 2–4

power cable connection, 2–6

power cords, 2–6

power supply LEDs, 4–1

- codes, 4–2

## **R**

---

rear bezel, 2–4

reconfiguring pedestal for two SCSI buses, 3–4

redundant cooling, 1–2

redundant power option, 1–2

redundant power supply, 1–4, 3–3

removable filler tab, 2–4, 2–5

removal of storage device, 4–5

replacement of blower, 4–8

replacement of storage device, 4–5

replacing a pedestal BBU, 4–7

replacing a pedestal power supply, 4–6

replacing a storage SBB, 4–5

reshipment, 2–1

routing SCSI cable, 2–4

## **S**

---

SCSI, 1–1

- cables and connectors, 2–1

- connector securing mechanisms, 2–2

- connectors, high-density, 2–1

- connectors, low-density, 2–1

- device addresses, 1–4, 3–1

SCSI "A" cable, 2–1, 2–3

- cable connections, 2–5

SCSI bus, 2–4, 3–4

- configuration rules, 3–4

- bus length inside pedestal, 3–4

SCSI drive

- 3.5-inch, 1–1

- 5.25-inch, 1–1

securing mechanisms, 2–2

setting address of storage devices, 3–2

shipping containers, 2–1

side mounted tabs, 1–2

single power supply status LEDs, 4–2

small computer system interface, (*see SCSI*)

status indicator LEDs, 1–2

storage array, 1–1

storage device, 1–1, 1–2

- configuration rules, 3–3

- device addresses, 3–2

- installation, 2–7

- status LEDs, 4–5

storage pedestal SCSI connectors, 2–4

switchbank, 1–2, 3–2

## **T**

---

target IDs, 1–4, 3–4

troubleshooting the pedestal, 4–11

typical pedestal configuration, 1–1

## **V**

---

visual fault indicators, 1–2, 4–1, 4–2, 4–3, 4–4, 4–5

# Reader's Comments

Manual Order Number:

Digital is committed to providing the best products and services. Since our manuals are important components of our products, we value your comments, corrections, and suggestions for improvements. Please take a few minutes to fill out and return this form. Attach additional sheets, if necessary. Thank you.

Manual Rating	Excellent	Good	Fair	Poor
Accuracy (correct presentation of facts)	[ ]	[ ]	[ ]	[ ]
Completeness (adequate information)	[ ]	[ ]	[ ]	[ ]
Clarity (easy to understand)	[ ]	[ ]	[ ]	[ ]
Organization (logical sequence of information)	[ ]	[ ]	[ ]	[ ]
Layout (easy to follow subject matter)	[ ]	[ ]	[ ]	[ ]
Indexing (easy to locate desired information)	[ ]	[ ]	[ ]	[ ]

**Errors Noted** (include page, paragraph, table or figure number)

---

---

---

**Most-Liked Features**

---

---

---

**Least-Liked Features**

---

---

---

**Suggestions for Improvement**

---

---

---

<b>Return Address:</b>  Digital Equipment Corporation OEM Mass Storage Business Technical Publications 334 South Street, SHR3-2/W3 Shrewsbury, MA 01545	Name _____ Phone _____
	Title _____
	Company _____
	Street Address _____
	Mail Stop _____
	City _____ State _____ ZIP _____
	Country (if other than USA) _____