



# DWZZH 16–Bit UltraSCSI Hub (Rack-Mountable)

---

User's Guide

EK–SMDZS-UG. B01

Compaq Computer Corporation  
Houston, Texas

---

## Second edition, November 1998

This equipment has been tested and found to comply with the limits for a Class B digital device, pursuant to Part 15 of the FCC rules. Operation is subject to the following two conditions: (1) This device may not cause harmful interference and (2) This device must accept any interference that may cause undesirable operation.

This equipment generates, uses, and can radiate radio frequency energy and, if not installed and used in accordance with the instructions, may cause harmful interference to radio communications. However, there is no guarantee that interference will not occur in a particular installation. If this equipment does cause harmful interference to radio or television reception, which can be determined by turning the equipment off and on, the user is encouraged to try to correct the interference by one or more of the following measures:

- Reorient or relocate the receiving antenna.
- Increase the separation between the equipment and receiver.
- Connect the equipment into an outlet on a circuit different from that to which the receiver is connected.
- Consult the dealer or an experienced radio/TV technician for help.

## Japanese VCCI Statement

この装置は、第一種情報処理装置（商工業地域において使用されるべき情報処理装置）で商工業地域での電波障害防止を目的とした情報処理装置等電波障害自主規制協議会（VCCI）基準に適合しております。  
従って、住宅地域またはその隣接した地域で使用すると、ラジオ、テレビジョン受信機等に受信障害を与えることがあります。  
取扱説明書に従って正しい取り扱いをして下さい。

Compaq Computer Corporation makes no representations that the use of its products in the manner described in this publication will not infringe on existing or future patent rights, nor do the descriptions contained in this publication imply the granting of licenses to make, use, or sell equipment or software in accordance with the description.

Possession, use, or copying of the software described in this publication is authorized only pursuant to a valid written license from Compaq or an authorized sublicensor.

The following are trademarks of Compaq Computer Corporation: Compaq, DEClaser, DIGITAL, OpenVMS, PATHWORKS, VAX DOCUMENT, and the Compaq logo.

# Contents

---

<b>Revision Record</b> .....	v
<b>About This Guide</b> .....	vii
<b>1 Introducing the 16-Bit UltraSCSI Hub (Rack-Mountable)</b>	
1.1 UltraSCSI Hub Features.....	1-1
1.2 Product Descriptions.....	1-2
1.2.1 DWZZH-S5.....	1-2
1.2.2 DWZZH-09.....	1-3
1.3 Product Specifications.....	1-4
<b>2 Setting Up the DWZZH-09</b>	
2.1 Set Up DWZZH-09.....	2-1
2.1.1 Install 0.5m Cable in DWZZH-09.....	2-1
2.2 Configuration Note.....	2-4
<b>3 Using the 16-Bit UltraSCSI Hub</b>	
3.1 Large Hub Fair Arbitration.....	3-1
3.2 Large Hub Addressing Configurations.....	3-2
3.2.1 Narrow Addressing Setting.....	3-2
3.3 Front Panel.....	3-4
3.3.1 Fair ARB Disable.....	3-6
3.3.2 Indicators.....	3-6
3.4 Determining the Configuration.....	3-8
3.5 Selecting the SCSI Cables.....	3-8
<b>4 Installing the DWZZH-09 Upgrade Kit</b>	
4.1 Install Upgrade.....	4-2
4.1.1 Install 0.5m Cable.....	4-2
<b>5 SWCC and UltraSCSI Hubs</b>	
5.1 Agents and Storage.....	5-1
<b>Appendix A Removable Parts of the DWZZH-S5 and DWZZH-09.....</b>	<b>A-1</b>
<b>Glossary.....</b>	<b>G-1</b>

**Figures**

1-1	DWZZH-S5 .....	1-2
1-2	DWZZH-09.....	1-3
2-1	Attach Tri-Link to Cable .....	2-1
2-2	Install Tri-Link and Cable in Storage Ports of SBBs.....	2-2
2-3	A Sample Configuration .....	2-3
2-4	Maximum Allowable Cable Distances .....	2-4
3-1	DWZZH-S5 SCSI ID Assignments.....	3-3
3-2	DWZZH-09 SCSI ID Assignments .....	3-4
3-3	DWZZH-S5 Front Panel.....	3-5
3-4	DWZZH-09 Front Panel .....	3-6
3-5	DWZZH-S5 SCSI Narrow ID Assignments .....	3-7
3-6	DWZZH-S5 SCSI Narrow Addressing Jumper .....	3-8
4-1	DWZZH-09 Upgrade Kit Contents .....	4-1
4-2	Install DWZZH-A5 SBB in Shelf .....	4-2
4-3	Attach Tri-Link to Cable .....	4-3
4-4	Install Tri-Link and Cable in Storage Ports of SBBs.....	4-3
5-1	Running One SWCC Agent for a Particular Storage Subsystem .....	5-2
A-1	Removable Parts of the DWZZH-S5 .....	A-2
A-2	Removable Parts of the DWZZH-09.....	A-2

**Tables**

1-1	UltraSCSI Hub Functional Specifications .....	1-4
A-1	Removable Parts of the DWZZH-S5 .....	A-1
A-2	Removable Parts of the DWZZH-09.....	A-1

## *Revision Record*

---

*The Revision Record provides a concise publication history of this guide. It lists the guide revision levels and release dates, and summarizes the changes.*

---

The following revision history lists all revisions of this publication and their effective dates. The publication part number is included in the Revision Level column, with the last entry denoting the latest revision. This publication supports the DWZZH 16-Bit UltraSCSI Bus Hub.

<b>Revision Level</b>	<b>Date</b>	<b>Summary of Changes</b>
EK-SMDZS-UG. A01	July 1998	Original Release.
EK-SMDZS-UG.B01	October 1998	Change 1st sentence in section 3.3.3; move section 3.3.3 from pg.3-6 to pg. 3-2.



## *About This Guide*

---

*This chapter tells you what this User's Guide does, identifies the audience, describes the structure and contents (chapter-by-chapter) briefly, and tells you how to get support and services from COMPAQ.*

---

This User's Guide describes the purpose, function, operation, and use of the DWZZH 16-Bit UltraSCSI Rack-Mountable Hub (the DWZZH Hub or the Hub). The DWZZH Hub allows the connection of up to five ports on one logical SCSI bus on the DWZZH-S5 model and up to nine on the DWZZH-09 unit.

### **Audience**

This guide is intended for end users and for COMPAQ employees responsible for configuring, installing, and maintaining the StorageWorks subsystem and its components.

### **Related Documentation**

You should be familiar with the information contained in the following documentation:

<b>Document Title</b>	<b>Order Number</b>
<i>StorageWorks Solutions Configuration Guide</i>	EK-BA350-CG
<i>StorageWorks Solutions Shelf and SBB User's Guide</i>	EK-BA350-UG
<i>StorageWorks SBB Shelf I/O Modules</i>	EK-SBBIO-UG
<i>StorageWorks UltraSCSI Configuration Guidelines</i>	EK-ULTRA-CG
<i>StorageWorks Solutions BA356-SB 16-bit Shelf User's Guide</i>	EK-BA356-UG

<i>Shared Storage Solutions Using UltraSCSI Hubs</i>	<i>EK-SMA21-AN</i>
<i>Shared Storage for Windows NT Using UltraSCSI Hubs</i>	<i>EK-SMA17-AN</i>
<i>Shared Storage for OpenVMS Using UltraSCSI Hubs</i>	<i>EK-SMA19-AN</i>
<i>Shared Storage for DIGITAL UNIX Using UltraSCSI Hubs</i>	<i>EK-SMA20-AN</i>
<i>Shared Storage for Sun Solaris Using UltraSCSI Hubs</i>	<i>EK-SMA18-AN</i>

## Document Structure

This guide contains the following chapters:

### **Chapter 1. Introducing the 16-Bit UltraSCSI Hub (Rack-Mountable)**

This chapter gives brief functional and physical descriptions of the DWZZH Hub and lists significant product specifications.

### **Chapter 2. Setting Up the DWZZH-09**

This chapter gives instructions for installing the 0.5m cable on the DWZZH-09 Hub.

### **Chapter 3. Using the 16-Bit UltraSCSI Hub**

This chapter gives procedures for configuring a StorageWorks SCSI bus using a DWZZH Hub.

### **Chapter 4. Installing the DWZZH-09 Upgrade Kit**

This chapter gives instructions for installing the DWZZH-09 Upgrade Kit in a DWZZH-S5.

### **Chapter 5. SWCC and UltraSCSI Hubs**

This chapter is intended to provide you with some important information regarding the use of StorageWorks Command Console (SWCC) on SCSI buses that have an UltraSCSI Hub. While the information provided here is important, it is essential that you have read the SWCC manual and release notes.

### **Appendix A. Removable Parts of the DWZZH-S5 and DWZZH-09**

This Appendix identifies the parts that can be removed and replaced from the DWZZH-S5/-09 16-Bit UltraSCSI Rack-Mountable Hubs.

### **Glossary**

The Glossary defines terms that are used frequently with StorageWorks and SCSI bus components.



## **Getting Help**

If you have a problem and have exhausted the information in this guide, you can get further information and other help in the following locations.

### **Compaq Web Site**

The Compaq Web Site has information on this product as well as the latest drivers and Flash ROM images. You can access the Compaq Web Site by logging on to the Internet at <http://www.compaq.com>.

### **Telephone Numbers**

For the name of your nearest Compaq Authorized Reseller:

In the United States, call 1-800-345-1518

In Canada, call 1-800-263-5868

For Compaq technical support:

In the United States and Canada, call 1-800-386-2172



# 1

## ***Introducing the 16-Bit UltraSCSI Hub (Rack-Mountable)***

---

*This chapter gives a brief physical description and describes the functions and functional specifications of the DWZZH-S5 and DWZZH-09 UltraSCSI Hubs.*

---

The series of DWZZH Hubs are SCSI-2 and draft SCSI-3 (ANSI X379.2/91-10R3) compliant capable with data transfer rates of up to 40 Mbytes per second. The two versions of these Hubs are:

- **DWZZH-S5:** A shelf-contained, rack-mountable, 5.25" SBB (large) Hub with four host ports and one storage port, all differential. See Figure 1-1.
- **DWZZH-09:** A shelf-contained, rack-mountable Hub consisting of two 5.25" SBBs (large) with eight host ports and one storage port, all differential. See Figure 1-2.

### **1.1 UltraSCSI Hub Features**

Most device SCSI buses are either 8-bit or 16-bit single-ended, physical buses. Some controllers and hosts use differential buses and others use a single-ended bus. Single-ended and differential physical buses are not compatible. The UltraSCSI protocol disables both buses when they are connected together. By using an UltraSCSI Hub you can accomplish the following:

- Provide radial disconnect where remaining connections can continue to operate.
- Provide *fair* SCSI arbitration for host nodes (DWZZH-05, -S5 and the -09 UltraSCSI Hubs only).

## 1.2 Product Descriptions

### 1.2.1 DWZZH-S5

A DWZZH-S5 large UltraSCSI Hub (See Figure 1-1) consists of two 180W power supplies, three bulkhead covers, a personality card cover, and a DWZZH-05 SBB mounted within a shelf. This model is rack-mountable, in either a horizontal or vertical position. Termination is provided by each of the host ports. A feature of the DWZZH-S5 Hub is that it is upgradeable from a five port Hub to a nine port Hub with the purchase of a DWZZH-09 Upgrade Kit. The kit contains another 5.25" SBB (large) Hub (DWZZH-A5), a tri-link and 0.5m cable, and instructions to complete the installation, and configuration for the upgrade.

**CAUTION**

Connecting a single-ended bus cable to the differential connector causes the SCSI bus to fail.

**Figure 1-1 DWZZH-S5**

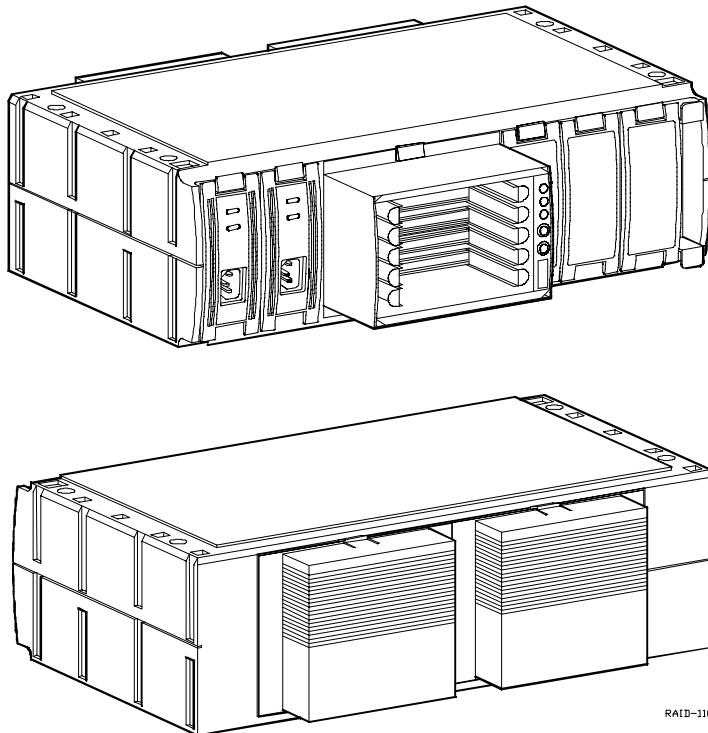

### 1.2.2 DWZZH-09

The DWZZH-09 is made up of two large Hubs connected by a 0.5m VHDCI cable (BN 37A-0E). A tri-link attached to the DWZZH-A5 portion of the Hub allows the attachment of a storage device up to 25 meters away from the Hub. The Hub provides radial connectivity by allowing the user to connect up to eight host bus adapters from any number of distributed systems to the DWZZH-09. Termination is provided by each of the host ports. (See Figure 1-2.)

Figure 1-2 DWZZH-09

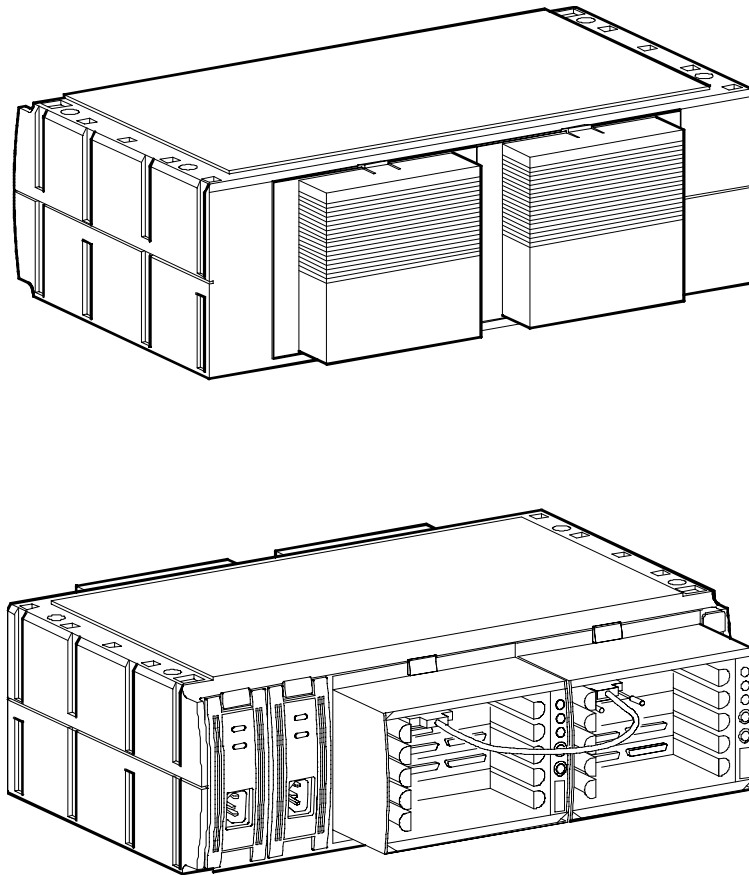

SHR-1105

### 1.3 Product Specifications

Table 1-1 lists the functional specifications for the DWZZH Hub.

**Table 1–1 UltraSCSI Hub Functional Specifications**

Feature	Specification
SCSI ID SCSI Addresses	The small UltraSCSI Hub does not use a SCSI ID. The large UltraSCSI Hub uses SCSI ID 7 for arbitration, when the fair arbitration option is enabled.
Overload Protection DTERMPOWER STERMPOWER	TERMPOWER is not supplied by the UltraSCSI Hub. Internal TERMPOWER is protected via a resettable fuse. TERMPOWER must be supplied from the remote connection to enable each Hub port.
Shielding, Enclosure & Connectors	Shielded for ESD, EMI, and safety requirements.
Power-Up Reset	Automatically clears: <ul style="list-style-type: none"> <li>• Initiator detection circuit</li> <li>• Target detection circuit</li> <li>• BSY glitch filter</li> </ul>
SCSI Bus Reset	Automatically clears: <ul style="list-style-type: none"> <li>• Initiator detection circuit</li> <li>• Target detection circuit</li> <li>• BSY glitch filter</li> </ul>
Differential SCSI Bus Length Ultra (20 megatransfers per second or 40 MB/s)	25 meters (82 feet) per segment. Refer to <i>Chapter 2, Section 2.2 Configuration Note</i> for more information regarding cabling distances.
Data Timing	The relationship between the data and the control signals is brought to SCSI compatibility before transmission to the other SCSI bus.
Design	High reliability SMT

**Table 1–1 DWZZH HUB Functional Specifications (Cont'd)**

<b>Feature</b>	<b>Specification</b>
Cable Fault	DIFFSENSE support and port disable on cable fault.
Glitch Elimination	100% glitch-free operation during power-up BUSY GLITCH trap eliminates cable length constraint due to wired-OR glitches on the BSY line.
<b>Termination</b>	
Differential	Termination for 16-bit operation.
Service There are no user serviceable functions on these products. Contact Digital service personnel all service.	
Agency Approvals UL, CSA, FCC Class B, TUV	
<b>Environmental Specifications</b>	
Relative Humidity	10% to 85% non-condensing
Operating Temperature	10°C to 40°C (50°F to 104°F)
Storage Temperature (non-operating)	–40°C to 66°C (–40°F to 151°F)
<b>Power Requirements</b>	
DWZZH	+5V
TERMPower	Supplied to internal terminators only.
<b>SCSI Connectors and Cables</b>	
Differential	Board-mounted, 68-pin VHDCI SCSI connector
Cables	Refer to <i>EK-ULTRA-CK.C01 UltraSCSI Configuration Guidelines</i> .





# 2

## Setting Up the DWZZH-09

---

*This chapter gives instructions for setting up and configuring the DWZZH-09 Hub.*

---

### 2.1 Set Up DWZZH-09

1. After removing the unit from the box, shipping material, and plastic bag, set it in a secure place or mount in a rack.
2. Remove the following parts from the shipping bag:
  - 0.5m Cable, P/N BN37A-0E
  - Tri-link

#### NOTE

If you do not have all of the above listed parts, contact your sales representative.

#### 2.1.1 Install 0.5m Cable in DWZZH-09

1. Attach the 0.5m cable to the top port of the tri-link, refer to Figure 2-1.

**Figure 2-1 Attach Tri-link to Cable**

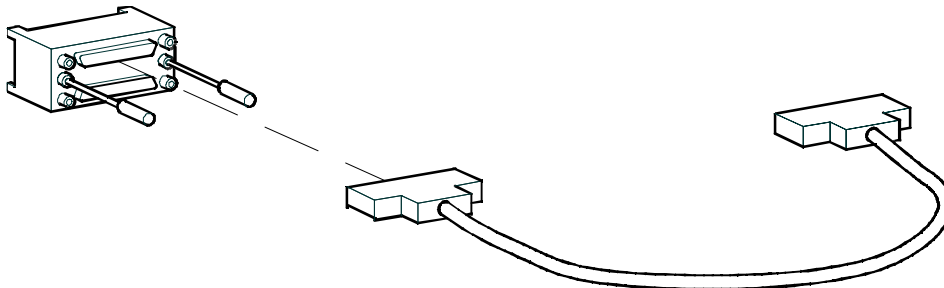

SHR-1109

2. Install and secure tri-link in storage port of right-hand SBB (-A5). Then install and secure the opposite end of the cable in the storage port of the left hand SBB (-05), Figure 2-2.

**Figure 2-2 Install Tri-link and Cable in Storage Ports of SBBs**

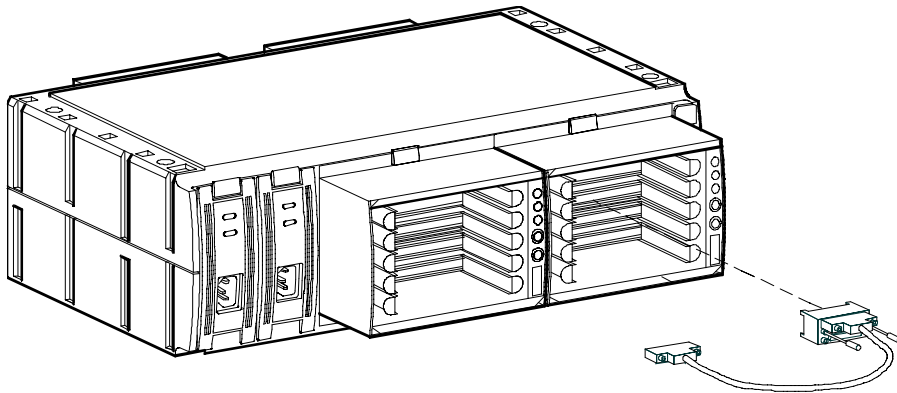

SHR-1110

3. Install power cords in power supplies on unit.
4. Attach the cables from your host bus adapters to their respective ports on the DS-DWZZH-09. Refer to *Chapter 3*, Figure 3-2 for the SCSI ID port assignments on the DS-DWZZH-09.
5. Connect your storage subsystem via cable to the remaining port on the tri-link attached to the right-hand SBB of the DS-DWZZH-09.

Figure 2-3 A Sample Configuration

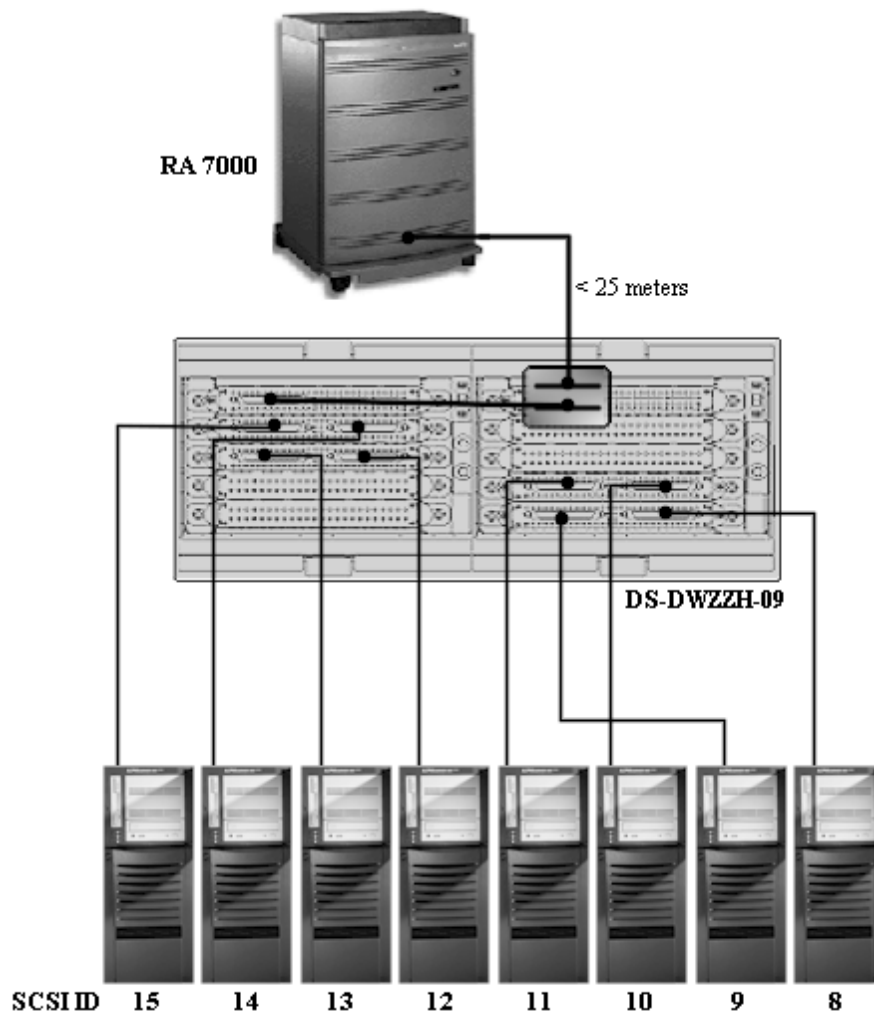

## 2.2 Configuration Note

According to the *UltraSCSI Configuration Guidelines* (included in your purchase), the maximum allowable cable distance for an UltraSCSI Domain is 74 meters. Each element, including the DWZZH-09 has an associated relative cable distance value associated. Cables count as their specified distance, (including the 0.5 meter jumper cable between the SBB Hubs); but each DWZZH SBB counts as an 18.5 meter cable equivalent. This means that communications from a server attached to the left-hand SBB to a server attached to the right-hand SBB, already has a 37.5 meter cable equivalent distance cost to propagate the signal through the DWZZH-09 Hub. Therefore, if the distance from server A to the Hub is  $X$ , and the distance from server B to the Hub is  $Y$ , then the sum cable distance of  $X$  and  $Y$  must be less than or equal to 36.5 meters ( $74 - 37.5$ ). Please note that any SCSI transaction from a host to the storage subsystem only propagates through *one* of the SBBs. This means that you may still have a cable length of 25 meters between the storage subsystem and the DS-DWZZH-09. Refer to Figure 2-4.

Figure 2-4 Maximum Allowable Cable Distances

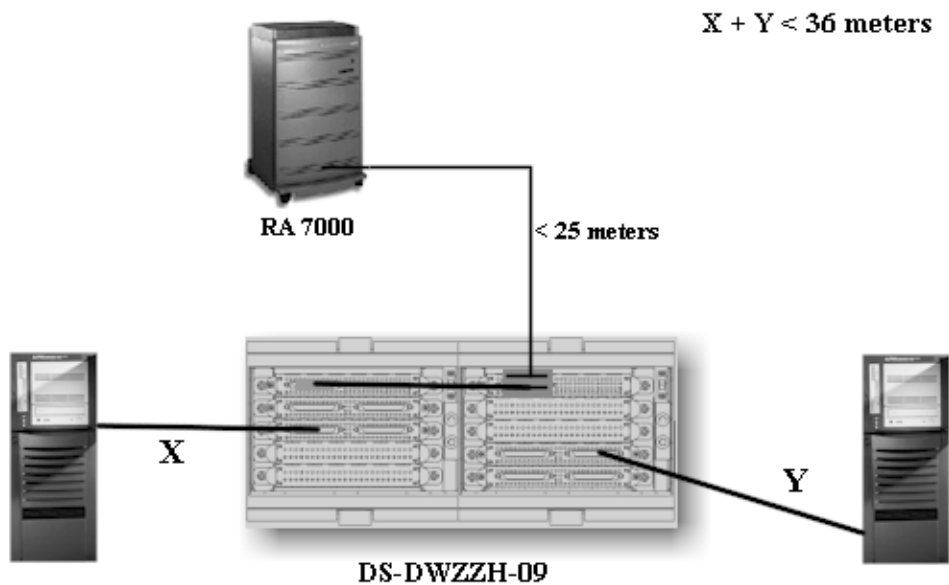

## Using the 16-Bit UltraSCSI Hub

---

*This chapter discusses fair arbitration of the SCSI bus by the 5.25" SBB Hub. It describes addressing configurations, tells you how to use the large Hub front panel, and gives guidelines for selecting the SCSI cables.*

---

UltraSCSI configuration guidelines are documented in *EK-ULTRA-CG*. These guidelines include a list of all UltraSCSI components and the last few example configurations include an UltraSCSI Hub. Refer to the configuration guidelines for bus length and SCSI bus data transmission rates.

### 3.1 Large Hub Fair Arbitration

The DWZZH-S5 and the DWZZH-09 can be operated with Fair Arbitration *enabled* or *disabled*. Although it is recommended that both be operated with Fair Arbitration enabled, it is not required.

In order to allow four or more *host* SCSI IDs to participate on a single SCSI bus and to prevent lower SCSI host IDs from being *starved* for bus time, a fair arbitration (Fair ARB) scheme is employed. Fair ARB works by assigning SCSI ID 7, the highest priority ID to the Hub. When a SCSI arbitration phase occurs, all the arbitrating IDs are captured in a register.

ID7 is *reserved* and may not be assigned to any SCSI device connected to the Ultra SCSI Hub, regardless of having FairARB enabled or disabled.

#### CAUTION

Most manufacturers ship Host Bus Adapters with a default SCSI ID of 7. Ensure that the ID is changed before establishing a connection between the adapter and the Hub.

The winning ID for this group will be the highest priority ID and allowed bus privilege. After this ID has completed its transaction, the ID will be removed from the group and at the next arbitration phase, the remaining highest ID will be serviced. This will continue until all of the IDs in the group have been serviced once. All requests from IDs not contained in the register will be *backed off* using ID 7.

After all the IDs in the group have been serviced, a new group of IDs will be captured at the next arbitration phase. The fair arbitration algorithm only applies to host port SCSI IDs as defined by the assignment in each configuration.

**CAUTION**

Running the UltraSCSI Hub under heavy I/O with Fair Arbitration disabled may result in SCSI bus starvation for hosts with low IDs.

### 3.2 Large Hub Addressing Configurations

The large UltraSCSI Hub has a specific SCSI ID configuration. The SCSI IDs are assigned to specific physical locations in the Hub. This allows the fair arbitration logic in the Hub to correctly identify the SCSI IDs that are participating in a fair arbitration cycle.

**CAUTION**

The SCSI ID of the HOST adapter must correspond to the assigned ID of the Hub port, to which the host port adapter is connected. Mismatched SCSI IDs will cause the SCSI bus to hang.

Figures 3-1 and 3-2 show the physical layout of the ports and their associated SCSI ID assignments on the DWZZH-S5 and DWZZH-09 Hubs.

#### 3.2.1 Narrow Addressing Setting

The large Hub can be used with SCSI bus architectures that are limited to eight ID assignments such as Digital Unix 4.x and earlier versions (Figure 3-5 shows narrow ID assignments). A jumper on the rear of the Hub (Figure 3-6) must be installed to make the Hub respond to SCSI IDs 3 – 0 on the host ports. It should be noted that the DWZZH-09 Hub cannot be put into a narrow addressing mode.

Figure 3-1 DWZZH-S5 SCSI ID Assignments

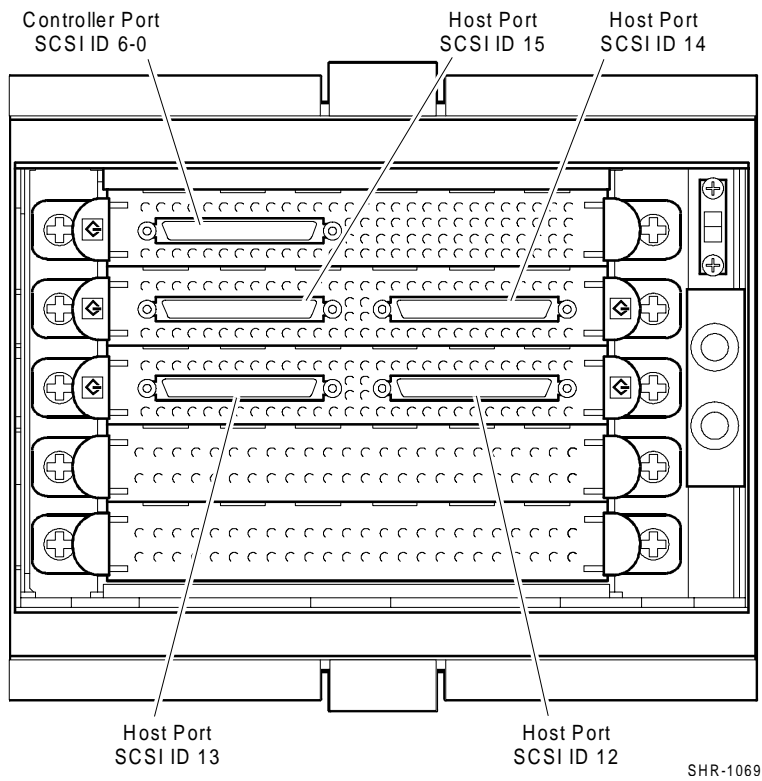
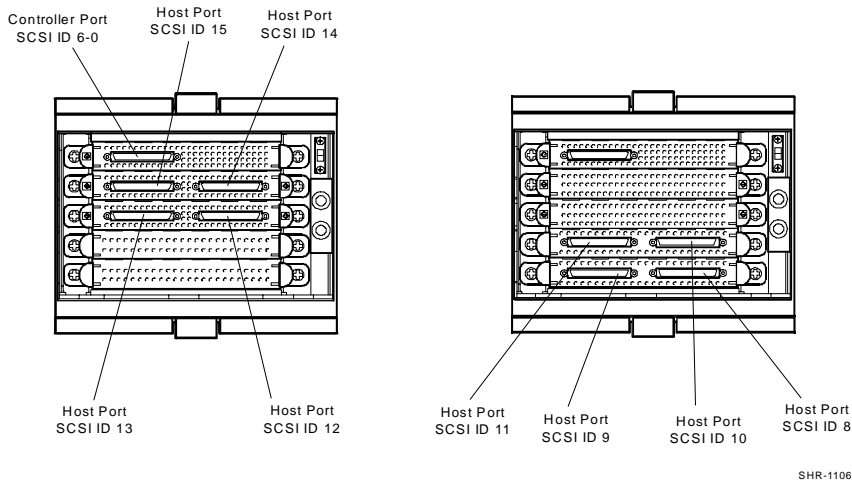

Figure 3-2 DWZZH-09 SCSI ID Assignments



### 3.3 Front Panel

Figures 3-3 and 3-4 show the location of the front panel controls and indicators for the DWZZH-S5 and the DWZZH-09 Hubs. The DWZZH-09 Hub has two SBBs with each SBB having a switch and LED indicator.

#### NOTE

It is recommended that the Fair Arbitration switch be set in *identical positions* on *all* Hubs residing on the same SCSI bus.



**NOTE**

The black part of the switch in Figure 3-3 indicates the position of the switch.

**Figure 3-3 DWZZH-S5 Front Panel**

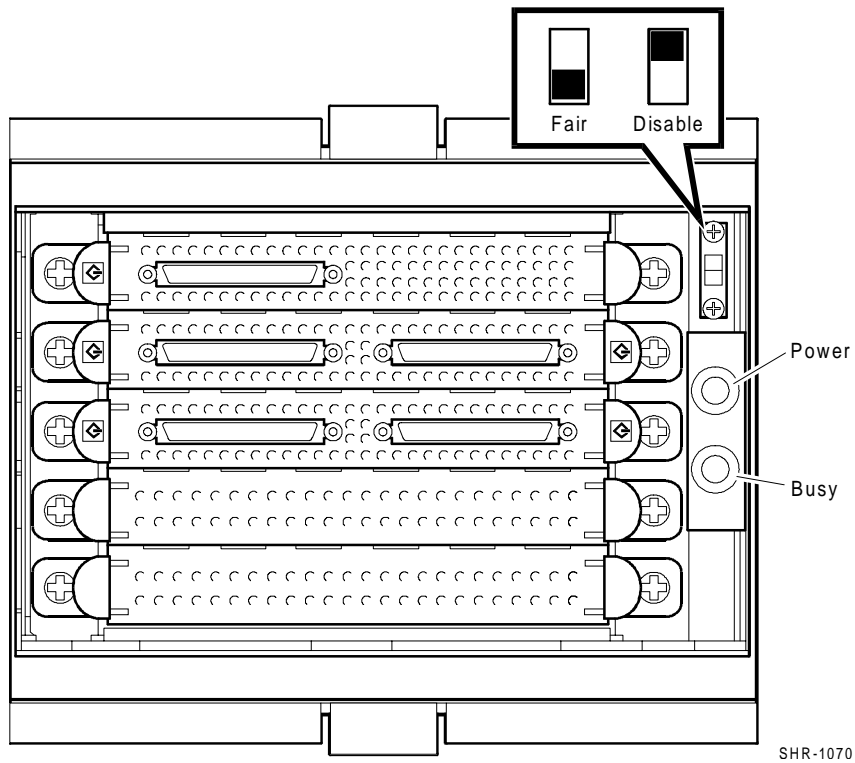
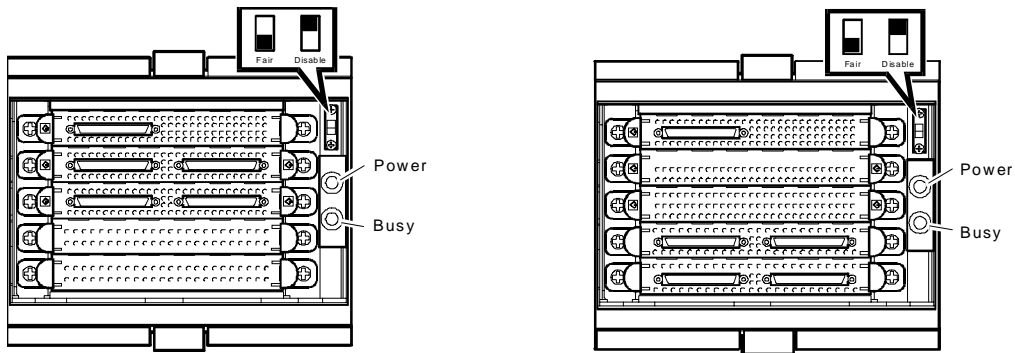

Figure 3-4 DWZZH-09 Front Panel



SHR-1107

### 3.3.1 Fair ARB Disable

The large Hub contains a switch on the front panel that allows the user to disable the *Fair ARB* feature of the Hub. When *Fair ARB* is disabled, the Hub services SCSI arbitration cycles in the conventional SCSI priority order. Host port SCSI ID assignments are not linked to the physical port location in the Hub when *Fair ARB* is disabled.

### 3.3.2 Indicators

The large Hub has two indicators on the front panel. The green LED indicates that POWER is applied to the Hub, while the yellow LED indicates that the SCSI bus is BUSY.

Figure 3-5 DWZZH-S5 SCSI Narrow ID Assignments

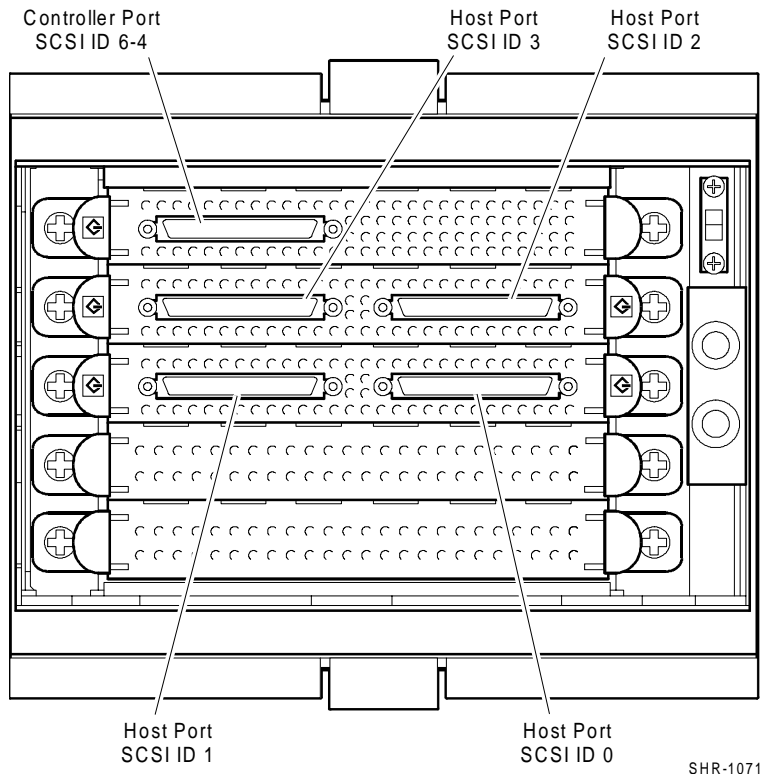

**Figure 3-6 DWZZH-S5 SCSI Narrow Addressing Jumper**

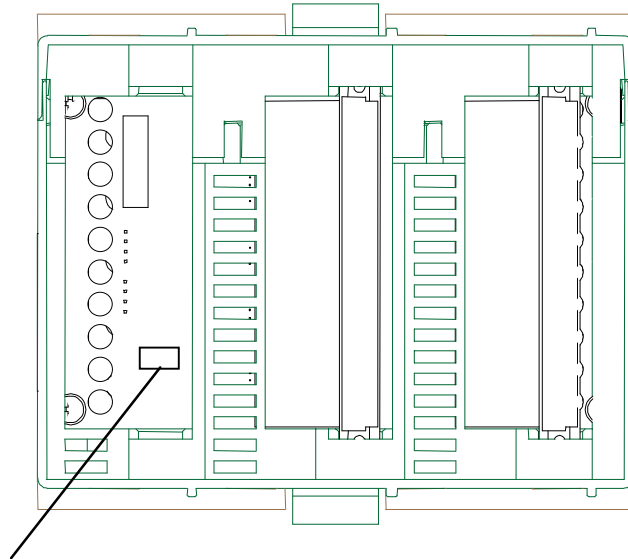

W1 (To enable narrow addressing mode, install a jumper at W1)

### 3.4 Determining the Configuration

The UltraSCSI Hub is used in end-bus SCSI bus configurations only. The SCSI bus segments require TERMPOWER supplied from the remote connection to enable the SCSI Hub port for that segment. Each port on the UltraSCSI Hub has its own terminators.

All SCSI buses are terminated at the physical ends of the bus. This is true even when using a DWZZH UltraSCSI Hub. DWZZH UltraSCSI Hubs are factory set to terminate the SCSI bus. No user configuration of the SCSI terminators is required.

### 3.5 Selecting the SCSI Cables

The *StorageWorks Solutions UltraSCSI Configuration Guide* describes SCSI cables in detail. When selecting a cable you must consider the cable connector clearance. Be sure to determine the type connector compatible with the controller connector. In some cases you must use a right-angle connector when connecting the cable to the Host Bus Adapter because there is not enough clearance to use a straight connector.

# 4

## *Installing the DWZZH-09 Upgrade Kit*

---

*This chapter gives instructions for installing a DWZZH-09 Upgrade Kit in a DWZZH-S5.*

---

It is possible to upgrade a DWZZH-S5, five port Hub to a DWZZH-09, with the purchase and installation of the DWZZH-09 Upgrade Kit. This kit contains (See Figure 4-1):

- One DWZZH-A5 5.25" SBB
- 0.5m Cable, BN37A-0E
- Tri-link, H8861-AA
- Bulkhead Cover

**Figure 4-1 DWZZH-09 Upgrade Kit Contents**

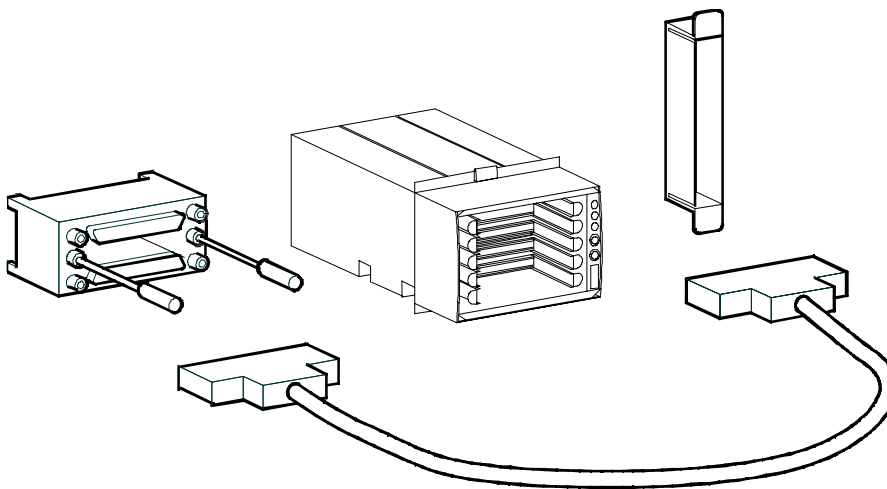

SHR-1113

**NOTE**

If the kit that you received does not include all items listed above, contact your sales representative.

#### 4.1 Install Upgrade

1. Remove DWZZH-A5 SBB from packaging.
2. Remove three bulkhead covers from the right-hand side of the DWZZH-S5 unit.
3. Slide the DWZZH-A5 SBB into the right-hand slots in shelf, where covers were just removed. See Figure 4-2.
4. Install personality card cover in unit.

**Figure 4-2 Install DWZZH-A5 SBB in Shelf**

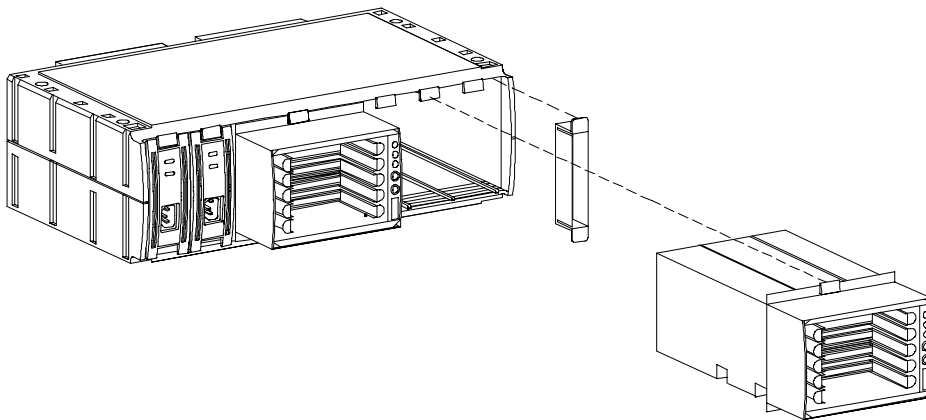

SHR-1114

##### 4.1.1 Install 0.5m Cable

1. Attach the 0.5m cable to the top port on the tri-link, refer to Figure 4-3.

**Figure 4-3 Attach Tri-link to Cable**

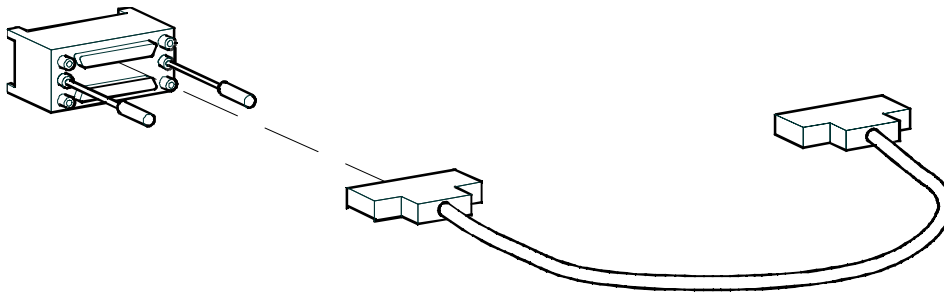

SHR-1109

2. Install and secure tri-link in storage port of right-hand SBB. Then install and secure the opposite end of the cable in the storage port of the left hand SBB, Figure 4-4.

**Figure 4-4 Install Tri-link and Cable in Storage Ports of SBBs**

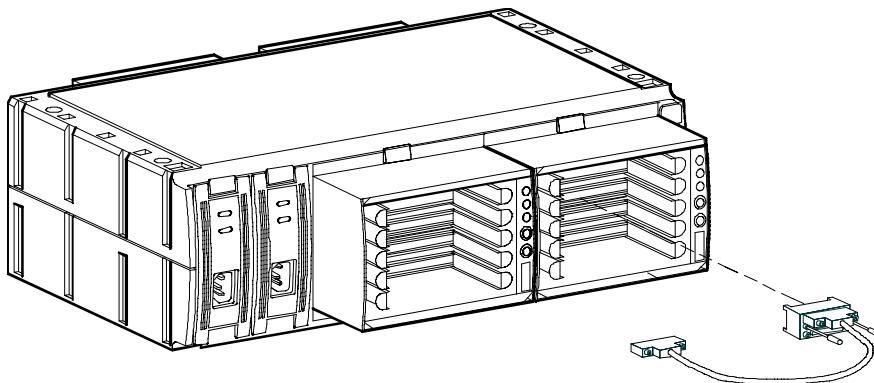

SHR-1110

3. Install power cords in power supplies on unit.





# 5

## *SWCC and UltraSCSI Hubs*

---

*This chapter is intended to provide you with important information regarding the use of StorageWorks Command Console on SCSI buses that have an UltraSCSI Hub. While the information provided here is important, it is essential that you have read the SWCC Manual and Release Notes.*

---

### **5.1 Agents and Storage**

It is highly recommended that you only run *one* SWCC agent on *one* of the servers that can access a particular storage subsystem behind the DS-DWZZH-09 UltraSCSI Hub. Using SWCC through the client-agent model is very similar to using a serial terminal to access the HSZ-70 controller; running multiple agents to access one storage subsystem would show up as multiple storage windows on the SWCC-Client machine. This could be a potential problem, as the Client would see multiple HSZ-70 subsystems, when in fact, only one exists, but is being displayed multiple times.

#### **NOTE**

If you have multiple storage subsystems behind the DS-DWZZH UltraSCSI Hub, be sure to name each of your storage subsystems uniquely and carefully (when you configure SWCC) so that you can distinguish between them easily.

The SWCC Graphical User Interface (GUI) neither displays when HSZ access ID restriction is being enforced nor prevents changes to restricted configurations from the GUI. For example, consider having four servers, each with a uniquely identified Host Bus Adapter attached to a DS-DWZZH 5-port UltraSCSI Hub, connected to a RA 7000 Subsystem with 24 disks (see Figure 5-1). Furthermore, consider the case where you have access ID restrictions configured such that each SCSI ID 12-15 could access a unique set of six disks in the storage cabinet.

This type of configuration would prevent systems with different SCSI IDs from accessing disks *'belonging to'* a particular SCSI ID, which promotes data security between servers on a shared SCSI bus; however, it *does not* prevent SWCC from performing tasks on those disks. In other words, if you set up the SWCC client to have configuration capability (see SWCC documentation) then you can access *everything* in the storage subsystem, regardless of HSZ-70 access ID restrictions.

For further information on setting up and configuring agents on HSZ controllers, please see the SWCC and controller documentation.

**Figure 5-1 Running One SWCC Agent for a Particular Storage Subsystem**

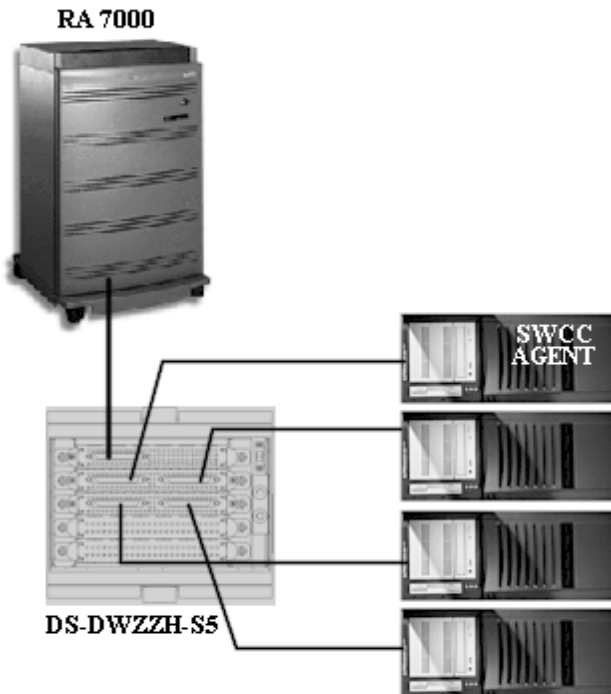



## ***Removable Parts of the DWZZH-S5 and DWZZH-09***

---

*This Appendix identifies the parts that can be removed and replaced from the DWZZH-S5/09 16-Bit UltraSCSI Rack-mountable Hubs.*

---

The following lists and illustrations identify the removable parts of the DWZZH-S5 and DWZZH-09 Hubs and are intended for reference purposes. See Figures A-1 and A-2.

**Table A-1 Removable Parts of the DWZZH-S5**

<b>Part Number</b>	<b>Description</b>
DS-DWZZH-05	UltraSCSI Hub Assy., 0SE & 5 Diff. Ports
DS-BA35X-HH	Power Supply, 180W, +5V, +12V
DS-BA356-SG	16-Bit Shelf Assy., w/FCC Mod's, TG Blue

**Table A-2 Removable Parts of the DWZZH-09**

<b>Part Number</b>	<b>Description</b>
DS-DWZZH-A5	UltraSCSI Hub Assy., 0SE & 5 Diff. Ports
DS-DWZZH-05	UltraSCSI Hub Assy., 0SE & 5 Diff. Ports
DS-BA35X-HH	Power Supply, 180W, + 5V, +12V
DS-BA356-SG	16-Bit Shelf Assy., w/FCC Mod's., TG Blue
H8861-AA	VHDCI Tri-link
BN37A-0E	0.5 meter VHDCI male/male cable

**Figure A-1 Removable Parts of the DWZZH-S5**

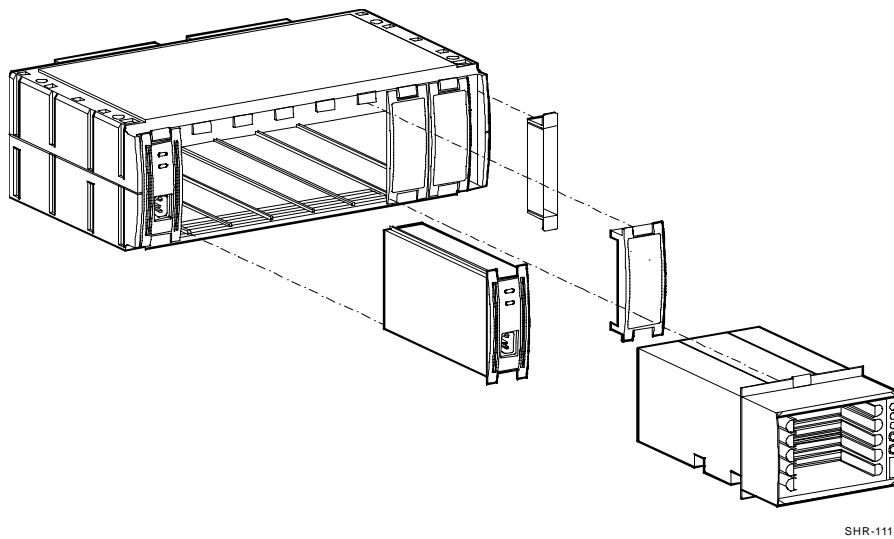

SHR-1111

**Figure A-2 Removable Parts of the DWZZH-09**

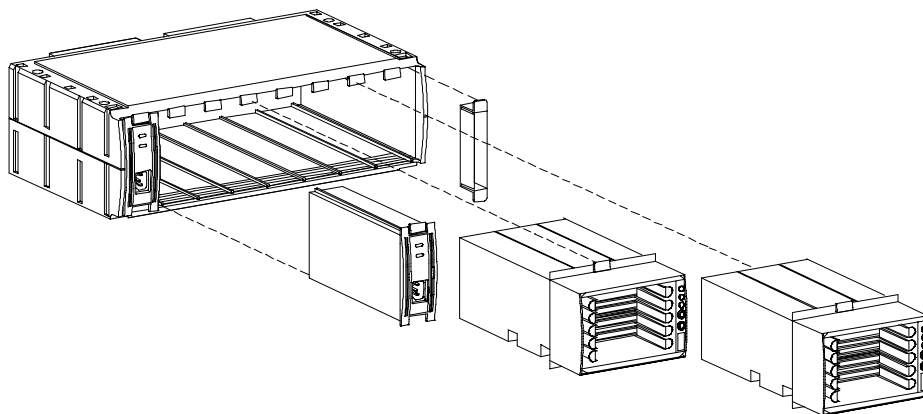

SHR-1112

# Glossary

---

*This Glossary includes an alphabetized listing and brief definition of the abbreviations, acronyms, COMPAQ-specific references, and other technical terms that are used in this manual and that may be unfamiliar to the reader.*

---

**adapter**

See SCSI bus converter.

**building block shelf**

See SBB shelf.

**controller**

A hardware/firmware device that manages communications on behalf of host systems over the SCSI bus to devices, such as the HSC-series, HSJ-series, and HSZ-series controllers. Controllers typically differ by the type of interface to the host and provide functions beyond what the devices support.

**differential SCSI bus**

A signal's level is determined by the potential difference between two wires. A differential bus is more robust and less subject to electrical noise than is a single-ended bus.

**DWZZC**

A StorageWorks compatible 16-bit SCSI bus converter.

See **SCSI bus converter**.

**DWZZH**

A StorageWorks compatible 16-bit UltraSCSI Hub.

**electrostatic discharge**

See **ESD**.

**ESD**

Electrostatic discharge is the discharge of a potentially harmful static electric voltage as a result of improper grounding.

**host**

The primary or controlling computer or any such unit (in a multiple computer network) to which storage is attached.

**initiator**

A SCSI device that requests another device on the bus to perform an operation. Any device on the bus can be an initiator or a target.

**logical bus**

A single-ended, physical bus connected to a differential, physical bus by a SCSI bus converter.

**personality module**

The BA356 module that interfaces the SCSI-bus to the BA356 shelf.

**physical bus**

Two SCSI terminators separated by cables, connectors, and/or the backplane circuitry.

**SBB**

StorageWorks building block. The basic building block of the StorageWorks product line. Any device conforming to shelf mechanical and electrical standards installed in either a 3½-inch or 5¼-inch carrier is considered to be an SBB, whether it is a storage device, a power supply, or other device.

**SBB shelf**

The common name for any StorageWorks shelf that contains only power supply and storage SBBs.

**SCSI**

Small Computer System Interface. This ANSI interface defines the physical and electrical parameters of a parallel I/O bus used to connect computers and devices. The StorageWorks subsystem implementation uses SCSI-2 for the transfer of data.

**SCSI bus converter**

Sometimes referred to as an adapter. (1) A connecting device that permits the attachment of accessories or provides the capability to mount or link units. (2) The device that connects a differential SCSI bus to a single-ended SCSI bus.

**SCSI device**

A host computer adapter, a peripheral controller, or an intelligent peripheral that can be attached to the SCSI bus.

**SCSI device ID**

The bit-significant, representation of the SCSI addressing referring to one of the signal lines numbered 0 through 15. Also referred to as target ID. For example, SCSI device ID 1 would be represented as 00001.

**SCSI mid-bus position**

The physical location of a controller or a device that the SCSI bus passes through enroute to the controller or device that contains the SCSI bus termination.

**SCSI cable**

A 68-conductor (34 twisted pairs) cable used for differential bus connections.

**single-ended SCSI bus**

A bus in which each signal's logic level is determined by the voltage of a single wire in relation to ground.

**Small Computer System Interface**

*See* SCSI.

**StorageWorks**

The Compaq set of enclosure products that allows customers to design and configure their own storage subsystem. Components include power, packaging, and interconnections in a StorageWorks shelf. SBBs and array controllers are integrated therein to form level enclosures to house the shelves. Standard mounting devices for SBBs are also included.

**StorageWorks building block**

*See* SBB.

**target**

A SCSI device that performs an operation requested by an initiator. Any device on the bus can be an initiator or a target.

**target ID**

*See* SCSI device ID.

**termpower**

Is an electrical current that is limited by self-resetting fuses.

**UltraSCSI**

Is an improvement in SCSI technology that was developed by the StorageWorks Engineering Group at Compaq Computer Corporation, and subsequently standardized by the ANSI SCSI committee (X3T10), which increases the maximum transfer rate on the SCSI bus from 10 MHz to 20 MHz (for a Wide SCSI bus this means an increase in maximum bus bandwidth from 20 MB/sec to 40 MB/sec).

