

**SWXTA-AA 2/4-GB, 4-mm, DAT
Tape Drive and SWXTA-LA
8/16-GB, 4-mm, Autoloader SBBs**

User's Guide

Order Number EK-SM2TA-UG. C01

Third Edition, November 1994

The information in this document is subject to change without notice and should not be construed as a commitment by Digital Equipment Corporation. Digital Equipment Corporation assumes no responsibility for any errors that may appear in this document.

Restricted Rights: Use, duplication, or disclosure by the U.S. Government is subject to restrictions as set forth in subparagraph (c) (1) (ii) of the Rights in Technical Data and Computer Software clause at DFARS 252.227-7013.

Digital Equipment Corporation does not give a warranty of any kind regarding the fitness or applicability of the information content for a particular purpose. The user assumes all responsibility for understanding the interrelationships of this enclosed information with other affected software or system products.

The disclosure of this information does not grant to the user a license under any patents, pending patents, trademarks, or copyrights or other rights of Digital Equipment Corporation, or of any third party.

FCC Notice: This equipment has been tested and found to comply with the limits for a Class B digital device, pursuant to Part 15 of the FCC rules. These limits are designed to provide reasonable protection against harmful interference in a residential installation. Any changes or modifications made to this equipment may void the user's authority to operate this equipment. The shielded interconnect cable, as supplied with the unit, may not be substituted, nor altered or modified, in any way.

FCC Notice: This equipment generates, uses, and may emit radio frequency energy. The equipment has been type tested and found to comply with the limits for a Class A computing device pursuant to Subpart J of Part 15 of FCC Rules, which are designed to provide reasonable protection against such radio frequency interference when operated in a commercial environment. Any changes or modifications made to this equipment may void the user's authority to operate the equipment. Operation of this equipment in a residential area may cause interference, in which case the user, at his own expense, may be required to take measures to correct the interference. If this equipment does cause harmful interference to radio or television reception, which can be determined by turning the equipment off and on, the user is encouraged to try to correct the interference by one or more of the following measures:

- Reorient or relocate the receiving antenna.
- Increase the separation between the equipment and receiver.
- Connect the equipment into an outlet on a circuit different from that to which the receiver is connected.
- Consult your reseller or an experienced radio/TV technician for help.

Copyright © Digital Equipment Corporation 1994
All Rights Reserved

Printed in U. S. A

The following are trademarks of Digital Equipment Corporation:

Digital

StorageWorks

VMS

and the Digital Logo:



All other trademarks and registered trademarks used in this publication are the property of their respective owners.

Contents

Revision Record	vii
About This Guide	ix
1 Introduction	
1.1 Product Overview	1-1
1.2 Design Features.....	1-1
1.2.1 What is Digital Audio Tape (DAT)?	1-1
1.2.2 What is Digital Data Storage (DDS)?.....	1-2
1.3 Data Formats.....	1-2
1.4 Support for Partitioned Tapes.....	1-3
1.5 Enhanced Performance.....	1-3
1.6 Intelligent Data Compression	1-3
1.7 Sophisticated Error Correction Procedures	1-3
1.8 Additional Features	1-3
2 Installation	
2.1 Introduction	2-1
2.2 Unpacking.....	2-1
2.3 Setting the SCSI ID Address of the Tape Drive.....	2-1
2.4 Installing the Tape Drive into a Storage Subsystem.....	2-2
2.5 Power On Self Test (POST)	2-3
3 Operation	
3.1 General	3-1
3.2 DAT Cassette Tape	3-2
3.3 Tape Drive LEDs	3-2
3.4 Using and Handling Cassette Tapes	3-3
3.5 Write-Protect Tab and Loading Cassette Tape	3-4
4 Maintenance	
4.1 Cleaning the Heads	4-1
4.2 Troubleshooting.....	4-2
5 Autoloader	
5.1 Overview	5-1
5.2 Indicators.....	5-2
5.3 Dot Matrix Display	5-2
5.3.1 Activity Messages.....	5-2
5.3.2 Status Messages	5-2
5.4 Operation.....	5-3
5.4.1 Automatic Operations	5-3

5.4.2	Manual Operations.....	5-3
5.4.3	Single Cassette Operation	5-4
5.5	Autoload/Display Switches	5-4
5.6	Routine Maintenance	5-5
5.6.1	Cleaning the Rollers	5-5
5.6.2	Cleaning the SWXTA-AA/LA Tape Drive and Autoloader.....	5-5

Appendix A Specifications

Appendix B Product Notes for Sun™

B.1	General Information.....	B-1
B.2	Modifications Required for SunOS 4.1.x.....	B-1
B.2.1	Installation Procedure	B-1
B.2.1.1	System Modification.....	B-2
B.2.1.2	Rebuilding of Kernel	B-2
B.2.1.3	Installation of tape drive	B-3
B.2.1.4	Rebooting of system	B-3
B.2.1.5	Testing the Tape Drive	B-3
B.2.1.6	Verification	B-3
B.2.2	Dump Parameters for the Tape Drive.....	B-4
B.3	Modifications Required for Solaris 2.3 (or later).....	B-4
B.3.1	Installation Procedure	B-4
B.3.1.1	System Modification.....	B-4
B.3.1.2	System Shutdown	B-6
B.3.1.3	Installation of the Tape Drive	B-6
B.3.1.4	Rebooting of System	B-6
B.3.1.5	Test	B-7
B.3.1.6	Verification	B-7
B.3.2	Dump Parameters for the Tape Drive.....	B-7

Appendix C Product Notes for Novell™, MS-DOS™, and Windows NT™

C.1	Host SCSI Interface	C-1
-----	---------------------------	-----

Reader Comment Form	Inside Back Cover
----------------------------------	--------------------------

Figures

1-1	StorageWorks SWXTA-AA 4 GB, 4 mm DAT Tape Drive.....	1-1
2-1	Tape Drive SCSI ID Switches	2-2
2-2	Tape Drive Cassette and Write-Protect LEDs.....	2-3
3-1	Front Panel Switch and LED Indicators.....	3-1
3-2	DAT Cassette Tape Write Enable/Protect Tab	3-2
5-1	SWXTA-LA Tape Auto Loader	5-1
5-2	Tape Auto Loader Front Panel	5-2
5-3	Auto Load/Display Switches SW2-1 through SW2-4	5-4

Tables

1-1	Drive Storage Capacity	1-2
1-2	Read/Write Compatibility Comparisons.....	1-3
2-1	SCSI ID Switch Settings	2-2
3-1	Tape Drive LED Status	3-2
4-1	Troubleshooting Table	4-2
5-1	Status Messages	5-3
5-2	Auto Load/Display Switch Settings and Functions	5-4
A-1	Tape Drive and Auto Loader SBB Specifications.....	A-1
A-2	Tape Drive and Auto Loader Noise Declaration.....	A-2

Revision Record

This Revision Record provides a concise publication history of this guide. It lists the manual revision levels, release dates, and reasons for the revisions. It also describes how the changes to affected pages are marked in the guide.

The following revision history lists all revisions of this publication and their effective dates. The publication part number is included in the *Revision Level* column, with the last entry denoting the latest revision. This publication supports the StorageWorks SWXTA-AA 2/4-GB*, 4-mm Tape Drive SBB and the SWXTA-LA 8/16-GB* 4-mm Autoloader SBB.

Revision Level	Date	Summary of Changes
EK-SM2TA-UG. A01	January 1994	Original release
EK-SM2TA-UG. B01	March 1994	Adds information describing autoloader option for the tape drive (Chapter 5). Also adds “Product Notes for Novell™ and MS-DOS™” (Appendix C).
EK-SM2TA-UG. C01	November 1994	Replaces original Appendix B (Product Notes for Sun™) with expanded version and updated Appendix C (Product Notes for Novell™, MS-DOS™, and Windows NT™) to add Windows NT™ information

*Storage capacity is 2 GB with uncompressed format; 4 GB compressed (assuming 2:1 compression).

NetWare™ is a trademark of Novell, Inc.

Microsoft® is a registered trademark of Microsoft Corporation.

MS-DOS™ and Windows™ are trademarks of Microsoft Corporation.

Sun™ is a trademark of Sun Microsystems, Inc.

SunOS™ and Solaris™ are trademarks or registered trademarks of Sun Microsystems, Inc.

Novell™ is a tradename of Novell, Inc.

About This Guide

This section identifies the users of this guide and describes its contents and structure. In addition, this section also includes a list of conventions used in this guide.

This guide provides product overview, installation, operation, and maintenance information for the StorageWorks SWXTA-AA 2/4-GB, 4-mm Tape Drive SBB (StorageWorks Building Block) and the SWXTA-LA 8/16-GB 4-mm Autoloader SBB.

Intended Audience

This guide is intended for people who will install, operate, and maintain the tape drive and autoloader SBBs.

Document Structure

This guide contains the following chapters:

Chapter 1: Introduction

Introduction gives an overview of the SWXTA-AA 2/4-GB tape drive, describes its components, and discusses the drive features. The information describes the 2 GB *native mode* and the 4-GB *compressed mode* (2:1 compression).

Chapter 2: Installation

Installation describes unpacking, setting the SCSI ID address, and how to install the tape drive in storage subsystems. The chapter also describes the tape drive POST test.

Chapter 3 Operation

Operation describes the tape drive LED indicators and how to use them to monitor tape drive operation.

Chapter 4 Maintenance

Maintenance describes how to clean the heads of the tape drive, and provides a troubleshooting table to help diagnose common problems.

Chapter 5 Autoloader

Autoloader describes the SWXTA-LA 16 GB tape autoloader option for the tape drive. A four-cartridge magazine provides up to 16 GB of storage (4 GB/cartridge) in the *compressed mode*.

Appendix A: Specifications

Specifications list the physical, electrical, cooling, environmental, and environmental stabilization specifications for the tape drive and loader.

*Storage capacity is 2 GB with uncompressed format; 4 GB compressed (assuming 2:1 compression).

Appendix B: Product Notes for Sun™

Product Notes for Sun™ describes the steps the system administrator must take to properly utilize the tape drive with the Sun™ operating systems.

Appendix C: Product Notes for Novell™ and MS-DOS™

Product Notes for Novell™, MS-DOS™, and WINDOWS NT™ provides information that should be read by the system administrator before installing the tape drive when it will be used with a host operating under the Novell, MS-DOS, WINDOWS, or WINDOWS NT operating systems.

Conventions

This guide uses the following conventions:

Documentation Conventions

Style	Meaning
boldface type	For emphasis
<i>italic type</i>	<i>For emphasis and manual titles</i>

NetWare™ is a trademark of Novell, Inc.

Microsoft® is a registered trademark of Microsoft Corporation.

MS-DOS™, Windows™, and Windows NT™ are trademarks of Microsoft Corporation.

Sun™ is a trademark of Sun Microsystems, Inc.

SunOS™ and Solaris™ are trademarks or registered trademarks of Sun Microsystems, Inc.

Novell™ is a tradename of Novell, Inc.

Introduction

This chapter provides a product overview of the StorageWorks SWXTA-AA 4-GB, 4-mm DAT Tape Drive.

1.1 Product Overview

The StorageWorks SWXTA-AA 4-GB, 4-mm DAT (Digital Audio Tape) tape drive (Figure 1-1) provides a high capacity, off-line data storage system. The tape drive is housed in an industry-standard 3.5-inch form factor called a StorageWorks Building Block (SBB). SBBs are designed to operate as storage devices in the StorageWorks family of storage subsystems such as the "Expansion Storage Pedestal".

Figure 1-1 StorageWorks SWXTA-AA 4-GB, 4-mm DAT Tape Drive

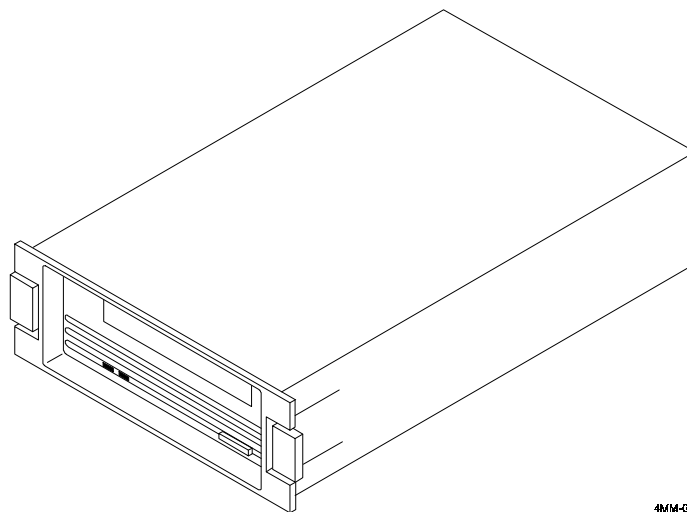

1.2 Design Features

The tape drive uses state-of-the-art technology. The drive's design incorporates both digital data storage (DDS) and digital audio tape (DAT) recording technologies.

1.2.1 What is Digital Audio Tape (DAT) ?

Digital audio tape takes advantage of the tape drive's helical scan technology. This technology allows data to be stored diagonally on the tape which allows more data to be stored on the tape. In addition, DAT recording minimizes *crosstalk*, providing you with enhanced data integrity.

1.2.2 What is Digital Data Storage (DDS) ?

Digital data storage uses a recording format that supports the use of digital audio tape for computer applications. The DDS/DAT format allows you to backup 4 gigabytes of data in approximately 6 hours, minimum, with no operator intervention (this performance figure will vary depending on computer hardware, operating systems, CPU utilization, and other application-specific parameters). In addition, this format has three levels of error correction which ensures a high degree of data integrity.

CAUTION

Use of non-DDS media may result in degraded drive performance and is not recommended by Digital Equipment Corporation.

1.3 Data Formats

The tape drive can read and write data in two formats as follows:

- In the *DDS* format, the drive can read data
- In the *DDS-C* format, the drive can read and write data

NOTE

The tape drive is internally set to default to the data compression mode. However, operating system commands or third party application software may change the drive recording function between the compressed and non-compressed modes.

When writing in the compressed format, the drive implements a powerful algorithm that enables it to compress user data at ratios of 2:1 or more. Table 1-1 shows the expected, or average, data capacity of the 60 and 90 meter tape cassettes.

Table 1-1 Drive Storage Capacity

Cassette Tape Type	Data Storage Capacity (GB)
TLZ04-CA (60 m)	2.6 [†]
TLZ06-CA (90 m)	4.0 [†]

[†] Storage capacity measurements are typical for a 2-to-1 compression ratio, but the actual data storage capacity is dependent on the data.

The actual compression ratio achieved depends on the type of data compressed. This guide assumes an average compression efficiency of 2:1. Table 1-2 compares the read/write compatibility of the SWXTA-AA, the SWXTA-LA, the TLZ04, and the TLZ06 (Digital Equipment Corp. part numbers of two similar tape drives using the standard DDS DAT reading technology).

Table 1-2 Read/Write Compatibility Comparisons

Drive Model No.	Read	Write	Tape Length (m)
SWXTA-AA, LA	Regular and Compressed	Compressed	60, 90
TLZ04 (DEC Part No.)	Regular	Regular	60
TLZ06 (DEC Part No.)	Regular and compressed	Regular and compressed	60, 90

1.4 Support for Partitioned Tapes

Some operating systems provide support for tape partitions. With these systems, the tape drive can read and write tapes containing either one or two partitions. Partitions provide an efficient way to maintain a directory on a tape without the risk of overwriting data when updating the directory.

1.5 Enhanced Performance

Assuming an average 2:1 compression ratio, the tape drive can achieve a sustained transfer rate of approximately 366 KBytes per second when writing in the compressed format. This translates to a maximum streaming speed of one GByte per second when performing data backup. In the non-compressed format, the transfer rate is 183 KBytes per second. The maximum time to backup (read or write) on a DAT cassette tape in a continual (streaming) mode is system dependent. The efficient use of *streaming mode* is determined by your operating system.

1.6 Intelligent Data Compression

The compression algorithm is completely contained in an integrated circuit. The tape drive invokes the compression algorithm intelligently, constantly monitoring the compression ratio to determine whether compressing the data will actually decrease the size of the data set.

1.7 Sophisticated Error Correction Procedures

The tape drive performs on-board error correction code (ECC) and error-recovery procedures, along with full read-after-write verification to ensure data integrity. The drive also contains a logical-block-CRC feature. By adding two bytes of cyclic redundancy check (CRC) data to every logical block on a compressed format tape, the drive can check that user data is compressed accurately.

1.8 Additional Features

The tape drive contains a single-ended SCSI controller. Additional features include SCSI-2 compatibility, synchronous data transfer, an integrated 1-MByte speed-matching buffer, full disconnect/reconnect arbitration support, and logical block packing. The tape drive is an easily integrated solution to your journalizing, archiving, data interchange, software distribution, imaging, data acquisition, and backup/restore needs.

This chapter shows you how to install the tape drive into a StorageWorks storage subsystem.

2.1 Introduction

The tape drive is housed in an SBB storage carrier and is designed for installation into the StorageWorks family of storage subsystems. The drive occupies one slot in the storage subsystem and is configured as one of up to seven devices on the SCSI bus. This chapter describes how to set the SCSI ID of the tape drive, how to install the device into a StorageWorks subsystem, and how to perform the Power On Self Test (POST) procedure. The information in this chapter is divided as follows:

- Unpacking
- Setting the SCSI address of the drive
- Installation into the storage subsystem
- POST test

2.2 Unpacking

Unpack and inspect the contents of your shipment. It should contain the following items:

- One SWXTA-AA 4-GB, 4-mm DAT cassette tape drive
- One blank 4-mm x 90 m cassette tape (TLZ04-CA)
- One head-cleaning cassette
- StorageWorks SBB user's guide
- This guide

Also, check the contents for damaged components. Notify your vendor immediately if any items are damaged. Keep all boxes and packing material for reshipment.

2.3 Setting the SCSI ID Address of the Tape Drive

The address switches on the rear of the tape drive SBB (Figure 2-1) are used to override the SBB default device address set by the storage subsystem. Setting these switches to *automatic* sets the device address to the storage subsystem's slot number. The switches are preset at the factory to *automatic*, but can be set manually to a different address at your option. Refer to Table 2-1 to reset the SCSI address if required.

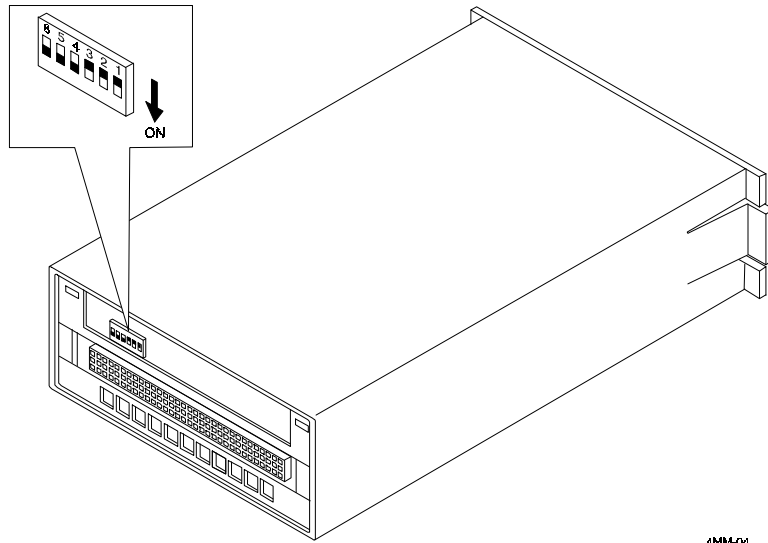
Figure 2-1 Tape Drive SCSI ID Switches

4MM-04

Table 2-1 Tape Drive SCSI ID Switch Settings

Address	SW-1	SW-2	SW-3	SW-4	SW-5	SW-6
0	Off	Off	Off	Off	Off	Off
1	On	Off	Off	Off	Off	Off
2	Off	On	Off	Off	Off	Off
3	On	On	Off	Off	Off	Off
4	Off	Off	On	Off	Off	Off
5	On	Off	On	Off	Off	Off
6	Off	On	On	Off	Off	Off
7*	On	On	On	Off	Off	Off
Automatic†	Off	Off	Off	On	On	On

* Normally reserved for host.

† Sets device address to storage subsystem slot number.

2.4 Installing the Tape Drive into a Storage Subsystem

CAUTION

Refer to Appendices B and C for instructions on your specific operating system before installing the drive and executing the power on self test procedure (Section 2.5.)

The tape drive SBB is installed in a storage subsystem by inserting the drive into any available SCSI device storage slot. The drive can be installed using the *hot-swap* method where the drive is installed with the host system powered on and operating, or with the

host system powered off. Consult your system administrator before using the *hot-swap* method to ensure your operating system supports this type of installation.

To install the tape drive:

1. If the tape drive is being installed into the StorageWorks Expansion Storage Pedestal subsystem, open the door on the front bezel and remove the bezel by pressing down on the locking tabs (bottom of the bezel) and pulling it forward.
2. Remove the filler panel from the desired slot location in the storage subsystem by squeezing the locking handles at the ends of the filler panel (or other SBB) and remove the panel.
3. Install the tape drive in the open slot and slide the drive in firmly until the locking handles snap into place. Proceed to the POST test below to verify the operation of the drive.

2.5 Power On Self Test (POST)

The POST test verifies the proper installation of the tape drive. The test may be performed with the storage subsystem power on (*hot-swap* method) if your operating system permits, or with the subsystem powered off. The following procedure assumes that the subsystem is off. Refer to Figure 2-2 for the locations of the front panel LED indicators on the drive. To execute POST:

NOTE

If the Write-Protect indicator flashes amber and the drive indicator flashes green continuously for more than 30 seconds in the following test, then the POST test has failed. Repeat the test to clear the failure (power off and then on). If the test still fails, replace the drive.

Figure 2-2 Tape Drive Cassette and Write-Protect LEDs

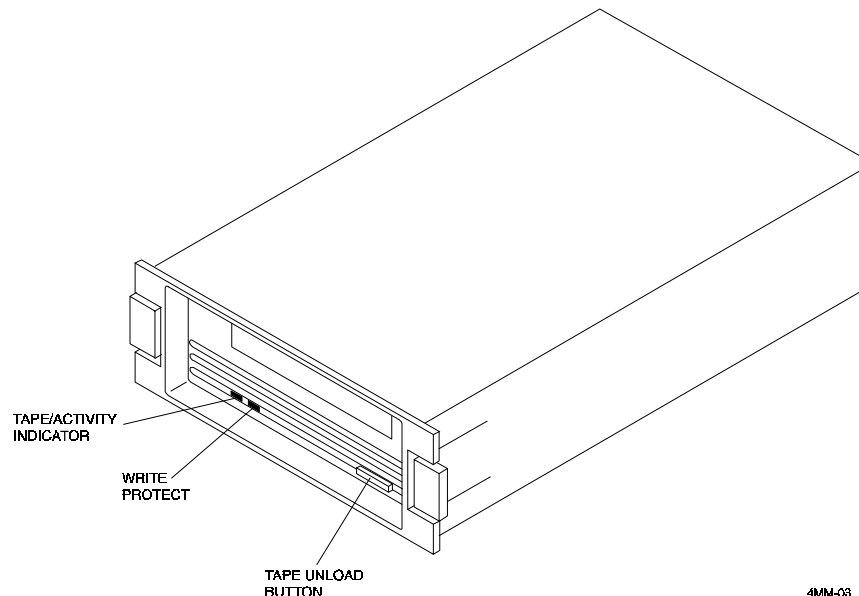

4MM-03

1. Ensure that there is no cassette tape in the drive.
2. Power on the storage subsystem and observe that the Cassette and Write-Protect indicators come on for approximately 1 to 5 seconds and then go out.
3. If the POST test is successful, the Cassette and Write-Protect LEDs should go out.
4. Load a cassette tape into the drive and observe the Cassette indicator. The indicator should continue flashing for approximately 20 seconds until the cassette is loaded, and then remain on.

After the test passes, have your system administrator assign a device name to the drive.

Operation

This chapter discusses the operation of the switch and the LED indicators on the front panel of the SWXTA-AA tape drive SBB.

3.1 General

The front panel of the cassette tape drive (Figure 3-1) is equipped with one push-button switch (*unload button*) and two indicators (*write protect* and *cassette* LEDs). The unload button is used to eject the cassette tape (press and hold for 1 to 2 seconds).

CAUTION

Pressing the unload button during normal tape operations may halt the tape and result in the loss of data.

The *write protect* indicator is an amber LED that comes on when the cassette tape is write protected. The *cassette* indicator is a green LED that lights continuously when a cassette is loaded, and flashes when there is drive activity.

Figure 3-1 Front Panel Switch and LED Indicators

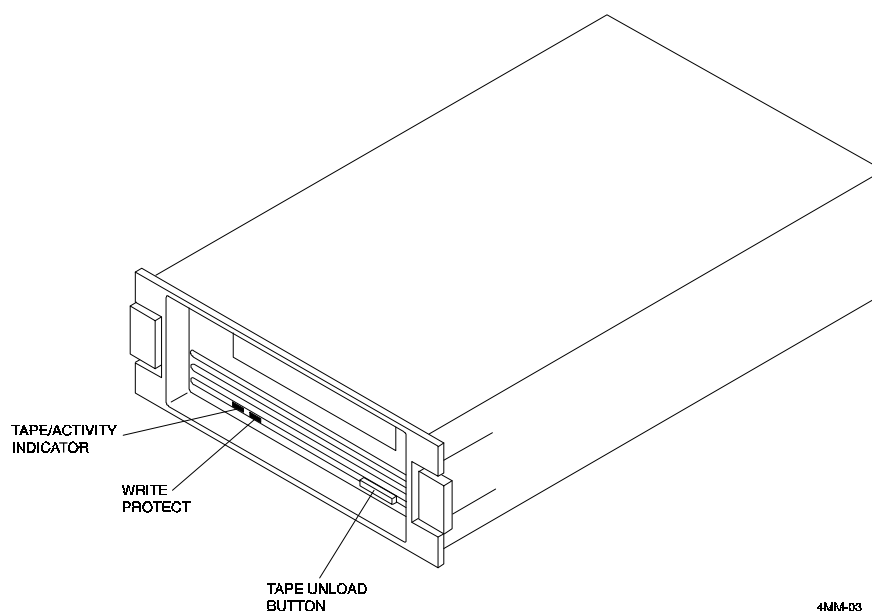

4MK4-03

3.2 DAT Cassette Tape

The cassette tape contains a write-protect tab (Figure 3-2) which contrasts in color to the body of the cassette tape. To "write-protect" the tape, slide the tab to the left. To "write-enable" the tape, slide the tab to the right (tab is not visible when the cassette tape is loaded in the drive).

NOTE

You can order the data cartridge (Part No. TLZ04-CB for 60 m, and TLZ06-CB for 90 m) and the cleaning cartridge (Part No. TLZ04-HA) by contacting your reseller or calling DECdirect at 800-DIGITAL. In Canada, dial 800-267-6215.

Figure 3-2 DAT Cassette Tape Write Enable/Protect Tab

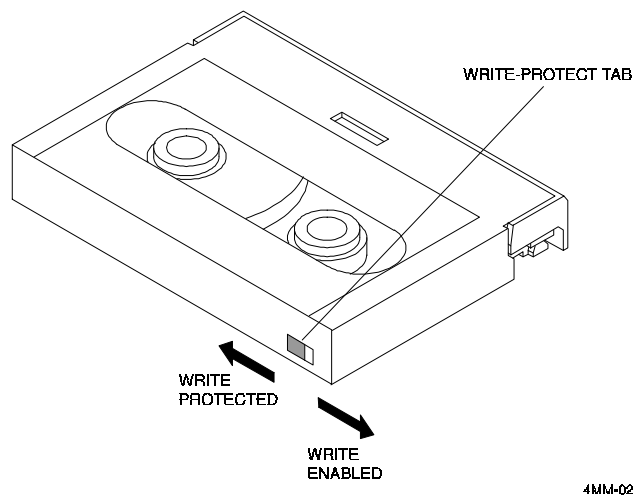

3.3 Tape Drive LEDs

The status of the tape drive is indicated by the *write-protect* and *cassette* LEDs. In the normal operating state, the *write-protect* LED only indicates the write-protect status and the *cassette* LED only indicates the drive activity and load status. Table 3-1 describes the status conditions represented by the LEDs. Refer to Figure 3-1 to identify the LEDs.

Table 3-1 Tape Drive LED Status

Status	Write-Protect LED	Cassette LED
No tape loaded.	Off	Off
Tape loaded, write enabled.	Off	Green
Tape loaded, write-protected.	Amber	Green
No SCSI/drive activity.	Off†	Green
SCSI/drive activity.	Off†	Activity

Table 3-1 Tape Drive LED Status (Con't)

Status	Write-Protect LED	Cassette LED
Load sequence.	Off†	Flashes green @ 1 Hz, 25% on. Green continuously when done. Indicates drive activity.
Unload sequence	Off†, goes off.	Flashes green @ 1 Hz, 25% on. Goes off when done. Indicates drive activity.
Reset sequence	Amber Off†	Green, flashing. Normal indications.
Power on self test (POST) Level 1 (basic) self test.	Flashes amber @ 2 Hz for length of test. Write protected when self test complete.	Flashes green @ 2 Hz for length of test. Normal activity indications when test complete.
Level 2 (extended) self test.	Off†	Flashes green until test complete (1 to 4 min.). Same as normal activity indication.
Test complete, no failure.	Resume normal operation, off†.	
Test failure, drive fault.	Flashes amber @ 2 Hz.	Flashes green @ 2 Hz.

† If DAT cassette is write-protected, write-protect LED will be amber.

3.4 Using and Handling Cassette Tapes

To ensure optimal performance from your cassettes tapes, observe the following guidelines when using and handling the tapes.

- Avoid placing the cassette tapes near sources of electromagnetic radiation such as terminals, video, or X-ray equipment. Radiation from this type of equipment can erase or corrupt data on the tape
- Keep cassette tapes out of direct sunlight and away from heaters and sources of heat
- Store cassette tapes and cleaning cassette at temperatures between 5° and 32° C (40° - 90° F)
- Store cassette tapes in a dust-free environment where the relative humidity is 20 to 60%

CAUTION

Always place the label in the recessed area on the cassette. Never place a label over another label. Also, use of non-DDS media could result in degraded performance of the drive.

3.5 Write-Protect Tab and Loading Cassette Tape

To read or copy from the cassette tape, set the write-protect tab to "write-protected" (Figure 3-2). This prevents writing to the tape and ensures that data will not be accidentally overwritten. Always use a pen not a pencil, to set the write-protect tab on the cassette tape. Use the following guidelines when setting the write-protect tab:

- If you are reading data (copying from tape), set the write-protect tab to write protect
- If you are writing data (writing to tape), set the write-protect tab to write-enabled
- When loading a cassette tape into the drive, ensure the cassette's write-protect tab is on the right, facing you

Maintenance

This chapter provides preventive maintenance and troubleshooting information for the SWXTA-AA tape drive and SWXTA-LA auto loader SBBs .

4.1 Cleaning the Heads

This section describes how to clean the heads of the tape drive. The heads are the components that physically read and write data to and from the cassette tape (media). We recommend that you perform the head cleaning procedure approximately every two weeks, or after 50 hours of drive usage. Under normal conditions, it should not be necessary to exceed this cleaning schedule. If a particular cassette causes problems, try another data cassette.

CAUTION

Never attempt to clean the heads in a manner other than described herein. Doing so will void the product warranty.

To clean the heads, use the head-cleaning cassette as follows:

1. Power on the storage subsystem to apply power to the tape drive.
2. Insert the head-cleaning cassette (Part No. TLZ04-HA) into the drive.
3. With the head-cleaning cassette inserted, the drive automatically executes the head-cleaning operation. The drive ejects the head-cleaning cassette after approximately 30 seconds.
4. Locate the card enclosed with the head-cleaning cassette and place a check mark on the card every time you use the head-cleaning cassette.

Under normal conditions, the head-cleaning cassette is effective for about 25 cleanings. If the head-cleaning cassette has been overused, both the *cassette* and the *write-protect* LEDs will flash. Press the *eject* button to remove the cleaning cassette. No cleaning action will have occurred.

4.2 Troubleshooting

Table 4-1 describes some common drive problems and suggests possible solutions.

Table 4-1 Troubleshooting Table

Symptom	Probable Cause	Possible Solution
Unable to back up or copy data to tape.	Cassette write-protected. No tape in drive.	1. Set write-protected tab on cassette to write-enabled. 2. Insert tape.
Write-protect LED flashes amber.	Excessive tape errors.	Perform head cleaning procedure (Section 4.1) . If error repeats, try another tape.
Both LEDs flash rapidly in unison.	Dirty heads or bad media.	Eject tape. Perform head cleaning procedure (Section 4.1) . If error repeats, try another tape.
	Drive error, possibly a hard failure.	Eject tape. Power off and power on the drive. If error repeats, replace the drive.
After applying power, nothing happens. All indicators off.	No tape loaded.	Load tape.
Drive not available to system.	Drive not plugged in.	1. Check ac power source.
	SCSI ID switches set to incorrect address.	2. Check SCSI ID switch.
	Defective SCSI cable.	3. Ensure power cable is plugged in and that the SCSI cable is seated properly.

Autoloader

This chapter describes the “Autoloader” option for the tape drive. It provides an overview of the loader followed by operation and maintenance information.

5.1 Overview

The SWXTA-LA tape autoloader (Figure 5-1) provides very high capacity unattended backup, as well as support for the full Random Access Command set as defined by SCSI-2. It is packaged in an industry standard 5.25-inch full-high form factor with an embedded SWXTA-AA 4-mm tape drive. The SWXTA-LA autoloader model is **not** a field upgrade option for the SWXTA-AA tape drive; it must be purchased as a single unit. With a four-cartridge magazine, the SWXTA-LA autoloader provides up to 16 gigabytes of storage (compressed).

Figure 5-1 SWXTA-LA Tape Autoloader

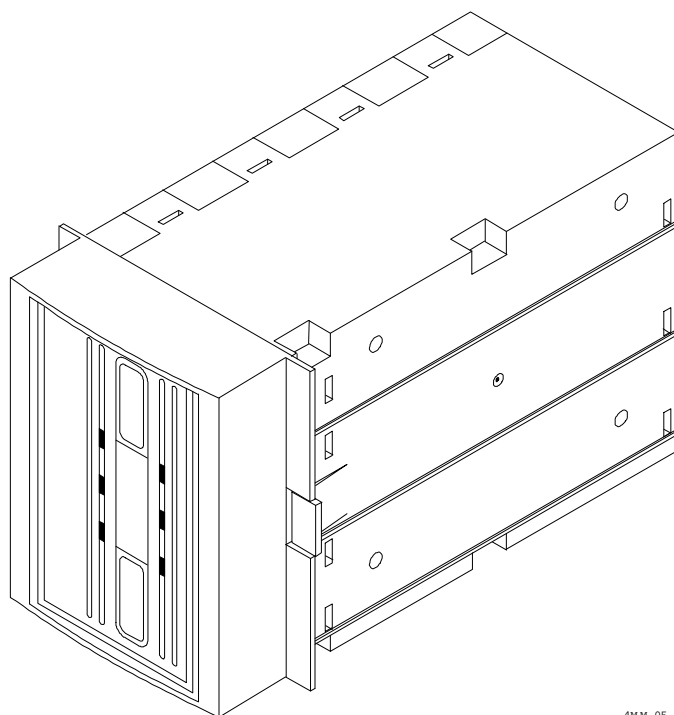

4MM-05

5.2 Indicators

The SWXTA-LA autoloader has four LED indicators. The labels for these LED indicators come with the autoloader. They are provided in four languages: English, French, German, and Spanish; and two orientations: vertical and horizontal. Choose your labels and place them on the bezel as shown in Figure 5-2.

The data compression LED (DC) is lit when data compression is enabled on the SWXTA-AA tape drive. Both the data compression LED and the LED above it (reserved) flash rapidly when a loader fault occurs. The reserved LED is reserved for future use. The write-protect and cassette LEDs are described in Chapter 3.

Figure 5-2 Tape Autoloader Front Panel

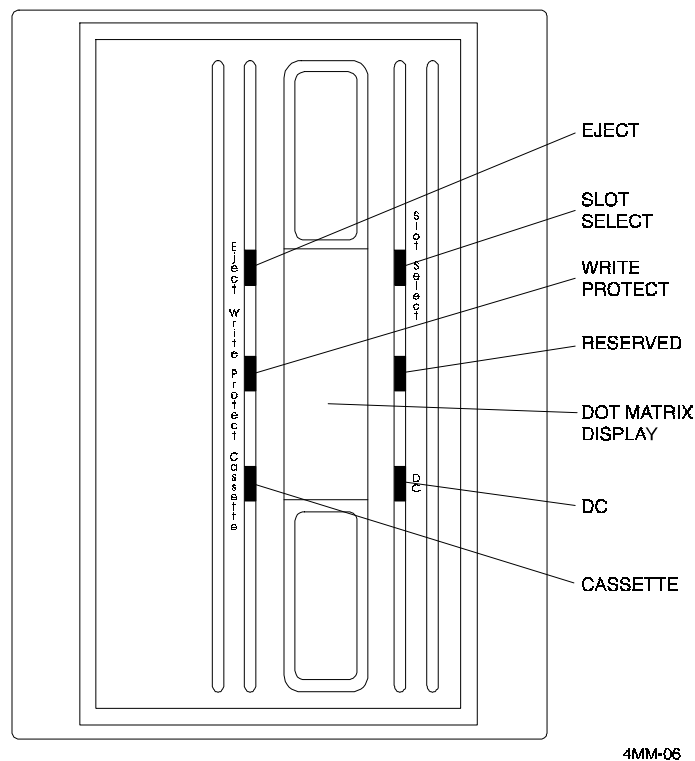

5.3 Dot Matrix Display

The dot matrix display shows two types of messages: activity and status.

5.3.1 Activity Messages

The dot matrix display has several activity messages: READ when the drive is reading, REWIND when it is rewinding and so forth.

5.3.2 Status Messages

The dot matrix display shows the current status of the autoloader when the drive is not active. Table 5-1 lists and describes the status messages.

Table 5-1 Status Messages

Message	Meaning
READY n	A cassette is loaded in slot n. The drive is ready to accept commands.
EMPTY	There is no magazine in the loader and no cassette in the drive.
SEL SLOT	A magazine is present in the loader, but there is no cassette in the drive. Use the select slot button to choose a slot to load.
OPERATOR	Same as EMPTY, but the drawer is open.
DISMOUNT	The drawer is open and the magazine has been unloaded. Remove the magazine or press the eject button to reinitialize the magazine.
CHK MAG	A cassette is loaded in the magazine incorrectly. The message alternates with the number of the slot you should check.
0 TAPES	The magazine you just loaded has no tapes in it.

5.4 Operation

The SWXTA-LA autoloader can be operated two ways: automatically or manually. It has two modes: sequential and random access.

5.4.1 Automatic Operations

During automatic operations, the SWXTA-LA autoloader can function in *sequential* and *random access* modes at the same time.

In the *sequential* mode, upon receipt of a SCSI unload command, the loader unloads the current cassette and automatically cycles to the next cassette in the magazine. It continues to unload and cycle to the next cassette until the last cassette has been unloaded. When this process is complete, the magazine stops to prevent accidental overwrite of data. Then the magazine may be unloaded.

In the *random access* mode, the loader responds to all of the SCSI random access commands.

5.4.2 Manual Operations

Manual operations are performed from the front of the autoloader.

To load a magazine, press the *eject* button. This opens the drawer and ejects any magazine that is in the drive. Then place the magazine in the mouth of the loader until the rollers engage the magazine. The loader automatically scans the magazine to make sure the cassettes are loaded correctly and to count the number of cassettes loaded. If a 4-cartridge magazine is installed, the drawer closes.

To load a cassette, press the *slot* button. Press it once to load the first cassette, twice to load the second cassette, and so on. If you make a mistake, continue pressing the *slot* button until the current state is shown on the dot matrix display. When you press the *slot* button, the loader displays the selected slot and allows some time for changes. Then the selected slot is automatically loaded and the drives becomes ready.

To eject the magazine, press the *eject* button. This ejects any cassette that is in the drive, opens the drawer, and ejects the magazine. Then you can remove the magazine.

5.4.3 Single Cassette Operation

If a magazine is in the drive, eject the magazine. When the mouth of the loader is empty, you can load a single cassette in the drive. The drive should accept the cassette and load it. To eject the cassette, press the *eject* button. The cassette moves into to the mouth of the loader. Then you can remove the cassette.

5.5 Autoload/Display Switches

The autoload/display switches are located inside the drawer and accessible when the drawer is open. Figure 5-3 shows a top view of the loader and the location of the switches. To gain access to SW2, remove the rubber dust plug over the switches. Two of the switches (SW2-1 and SW2-2) are functional and two (SW2-3 and SW2-4) are reserved.

Figure 5-3 Autoload/Display Switches SW2-1 through SW2-4

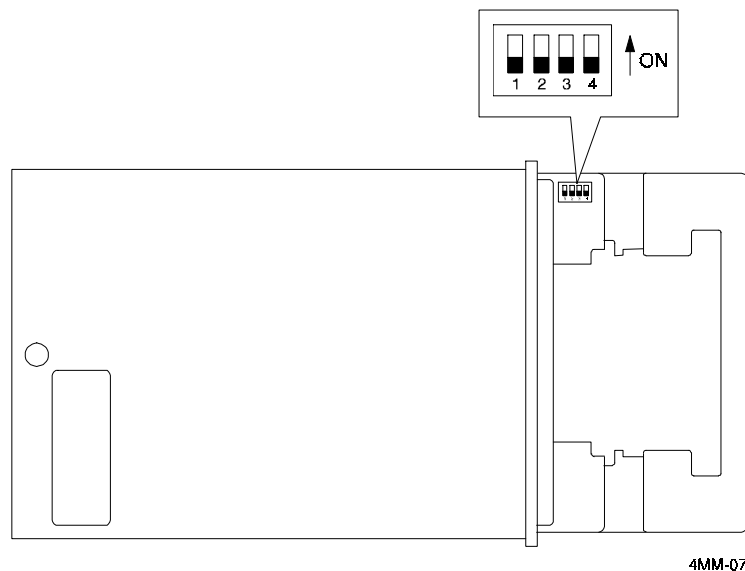

You can select a vertical or horizontal orientation of the dot matrix display by setting switch SW2-1. When you set this switch to on, the dot matrix is vertical (left side down).

SW2-2 controls the loading function of the first cassette into the loader. When set this switch to on, the autoloader automatically loads the first cassette upon magazine insertion. Table 5-2 lists the settings and functions of the autoload/display switches.

Table 5-2 Autoload/Display Switch Settings and Functions

Switch	Function
SW2-1	Display Orientation
SW2-2	Auto-load
SW2-3	Reserved
SW2-4	Reserved

5.6 Routine Maintenance

5.6.1 Cleaning the Rollers

Digital Equipment Corporation recommends that you clean the rollers about once every 6 months or after 10,000 load/unload cycles. Follow these steps:

1. Open the drawer and remove the magazine.
2. Dip a cotton swab in ethyl alcohol.
3. Press the *slot select* button three times in a 3-second period. This starts rotation of the cassette rollers. They rotate for 15 seconds while the display reads **CLEAN 1**.
4. Wipe the rollers with the wet end of the swab for a few seconds as they rotate.
5. Wipe the rollers with the dry end of the swab for a few seconds as they rotate.
6. Again, press the *slot select* button three times in a 3-second period. This starts rotation of the left magazine rollers. They rotate for 15 seconds while the display reads **CLEAN 2**.
7. Repeat steps 4 and 5.
8. Again, press the *slot select* button three times in a 3-second period. This starts rotation of the right magazine rollers. They rotate for 15 seconds while the display reads **CLEAN 3**.
9. Repeat steps 4 and 5.

5.6.2 Cleaning the SWXTA-AA/LA Tape Drive and Autoloader

Refer to Chapter 4, Section 4.1, for information on cleaning the SWXTA-AA tape drive and the SWXTA-LA tape autoloader SBBs.



Specifications

This appendix describes the physical, electrical, and environmental specifications for the SWXTA-AA tape drive and SWXTA-LA autoloader SBBs.

Table A-1 Tape Drive and Autoloader SBB Specifications.

Characteristic	Specification(s)
Tape Drive Dimensions (SWXTA-AA)	8.5 x 5 x 1.875 in. (216 x 127 x 48 mm)
Tape Drive Weight (SWXTA-AA)	2.2 lbs. (1 kg.)
Auto Loader Dimensions (SWXTA-LA)	8.5 x 5 x 1.875 in. (216 x 127 x 48 mm)
Auto Loader Weight (SWXTA-LA)	7.6 lbs.
Mode of operation	Streaming, and start/stop
Drive interface	SCSI-2
Media (4 mm x 60 m)	TLZ04-CA cassette tape
Media (4 mm x 90 m)	TLZ06-CA cassette tape
Bit density	114 Mbits per square inch
Transfer rate (sustained)	366 Kbytes, compressed [†]
Recording format	Digital data storage (DDS and DDS-C)
Cassette capacity (typical)	4 gigabytes with 90-meter tape and data compression [†]
Passes per cassette tape	300
Power consumption	9 W
Power requirements	+5 Vdc, 0.89 A +12 Vdc, 0.2 A
Operating temperature	50° to 104° F (10° to 40° C)
Non operating temperature	-40° to 158° F (-40° to 70° C)
Operating humidity	20 to 80% RH, maximum, non condensing
Non operating humidity	5 to 95% RH maximum, non condensing
Operating altitude	0 to 15,000 ft. (0 to 4.6 km)
Non operating altitude	0 to 50,000 ft. (0 to 15.2 km)

[†] Assumes a 2:1 compression ratio.

Table A-2 2/4-GB, 4-mm DAT Tape Drive Noise Declaration

Acoustics - declared values per ISO 9296 and ISO 7779:		
Operating Mode	LwAd	LpAm (bystander positions)
Idle	4.5 B [†]	32 dBA
Operating	4.7 B	33 dBA

† 1 B = 10 dBA



Product Notes for Sun™

This appendix describes how to include the SWXTA-AA tape drive SBB in a Sun SPARC system running Solaris™ 2.3 (or later) or SunOS™ 4.1.x. The information covers configuration of the host system to communicate with the tape drive.

B.1 General Information

You must rebuild your kernel, with the parameters given, to ensure that your device functions properly.

When using the **dump** utility under SunOS 4.1.x, you must supply the correct “d bpi” (density code) and “s size” tape length for **dump** to calculate the correct number of tapes required. The “b factor” (blocking factor) is of less importance, and we recommend a value of 126 for that parameter.

Compression can be enabled/disabled at any time by selecting the appropriate device file. See the following sections on “st_conf.c” and “st.conf” for details on how we configure density codes.

In general, the density code hex value 0xfd turns off compression and the code 0xfe turns it on. Since four driver variations are created, a number of combinations are possible. We configured our systems for two drivers without compression and two drivers with compression; you may decide that some other combination is more suitable for your system.

B.2 Modifications Required for SunOS 4.1.x

B.2.1 Installation Procedure

NOTES

1. The "DEC TLZ06" designation in the following procedure is the StorageWorks internal name for the tape drive, as incorporated in and used by the firmware.
2. In order to support the addition of this device, your system's /sys/scsi/targets/st_conf.c file must contain the applicable drive information. For additional information on this requirement, read the **man** pages for "st".

Sun™, SunOS™ and Solaris™ are trademarks or registered trademarks of Sun Microsystems, Inc.

B.2.1.1 System Modification

Perform the following steps to modify the system for communication with the tape drive:

1. From the command line, type:

```
cd /sys/scsi/targets
```

2. Edit the "**st_conf.c**" file and *carefully* add the following structure before the "/* TLZ06 4mm 2GB */" entry:

```
/* Entry for DEC TLZ06. DAT 4mm Helical Scan tape drive, /w Compression.
*/
{
    "DEC 2GB 4mm Helical Scan", 13, "DEC^^^^^TLZ06",
    ST_TYPE_DEFAULT, 512,
    (ST_VARIABLE | ST_BSF | ST_BSR | ST_LONG_ERASE | ST_KNOWS_EOD),
    5000, 5000,
    { 0xfd, 0xfd, 0xfe, 0xfe },
    { 0, 0, 0, 0 }
},
```

3. Verify that the above entry is added to the `st_conf.c` file correctly.

Where,

- The first parameter (DEC 2GB 4mm Helical Scan) is the name given to the drive.
- The second parameter (13) is the length of the vendor ID provided by the "inquiry" command.
- The third parameter (DEC^^^^^TLZ06) is the vendor ID. (Ensure that five spaces are included between "DEC" and "TLZ06" elements.)
- The fourth parameter (ST_TYPE_DEFAULT) is the drive type for the driver.
- The fifth parameter (512) is the block size in bytes.
- The sixth parameter (ST_VARIABLE | ST_BSF | ST_BSR | ST_LONG_ERASE | ST_KNOWS_EOD) comprises the drive options.
- The seventh parameter (5000) is the maximum number of read retries.
- The eighth parameter (5000) is the maximum number of write retries.
- The ninth parameter (0xfd, 0xfd, 0xfe, 0xfe) comprises the density codes (low _ hi) as defined below:
 - 0xfd is the vendor-unique density code for the tape in the uncompressed mode (2.0 GB).
 - 0xfe is the vendor-unique density code for the tape in the compressed mode (4.0 GB, assuming a 2:1 compression ratio).
- The tenth parameter (0, 0, 0, 0) is the speed code (not used).

B.2.1.2 Rebuilding of Kernel

After you have edited the "**st_conf.c**" file and added the above entry, rebuild the kernel using the standard procedure (for further help, refer to the **man** pages of the **config** command).

B.2.1.3 Installation of tape drive

Install the tape drive into the storage subsystem and power on the workstation. We recommend that the tape drive's SCSI device address be set to ID 4 or to ID 5.

NOTE

If your SCSI host adapter is supported by the "probe-scsi" command, you can use this command at the boot prompt to verify that the connected device is correctly attached to the system.

B.2.1.4 Rebooting of system

Reboot the system, using the following command at the boot prompt:

```
>boot
```

The system reboots with the newly compiled kernel and creates special files in `/dev` so that it can communicate with the tape drive. Verify that "DEC 4GB 4mm Helical Scan" is displayed as a target when the system is booting.

At this time the tape is configured in the `/dev` directory with "**rst**" (rewind on close) and "**nrst**" (no rewind on close) format. If the entry in the kernel configuration file for the tape drive were **st0**, for example, then "**rst**" would be "**rst0, rst8, rst16, rst24**" and **nrst** would be "**nrst0, nrst8, nrst16, nrst24**".

- **rst0** and **nrst0** correspond to the **0xfd** density mode (*uncompressed* format).
- **rst8** and **nrst8** correspond to the **0xfd** density mode (*uncompressed* format).
- **rst16** and **nrst16** correspond to the **0xfe** density mode (*compressed* format).
- **rst24** and **nrst24** correspond to the **0xfe** density mode (*compressed* format).

B.2.1.5 Testing the Tape Drive

To test the tape drive, back up the "**passwd**" file to tape using the "tar" command, as follows:

```
tar -cvf /dev/rst0 /etc/passwd
```

The system responds with something similar to the following:

```
a /etc/passwd 1 blocks
```

Note that depending on the size of the file, a different number of blocks may be reported.

B.2.1.6 Verification

Verify that the "**passwd**" file was written to tape using the following command:

```
tar tvf /dev/rst0
```

The system responds with something similar to the following:

```
rw-r--r-- 0/10 535 Mar 23 16:31 1994 /etc/passwd
```

The installation and verification procedure is now complete.

B.2.2 Dump Parameters for the Tape Drive

The parameters that should be used when running the dump utility with the tape drive are:

density = 61000
size = one of the following, as appropriate:
 6656 (for 60 meter tapes)
 10240 (for 90 meter tapes)
blocking factor = 126

Example 1

The following example shows the command for backing up an entire disk partition onto the tape drive, using a 90-meter tape:

```
dump 0dsbf 61000 10240 126 /dev/rst0 /dev/sd0g
```

For further help, refer to **man** pages of the **dump** command.

B.3 Modifications Required for Solaris 2.3 (or later)

B.3.1 Installation Procedure

NOTES

1. The "DEC TLZ06" designation in the following procedure is the StorageWorks internal name for the tape drive, as incorporated in and used by the firmware.
2. In order to support the addition of this device, drive information must be supplied in the `/kernel/drv/st.conf` file as global properties that apply to each of the targets, or as properties that are applicable to one target only. The "st driver" looks for the property called "tape-config-list". For additional information, read the **man** page "st". We recommend here the use of the global properties approach.

B.3.1.1 System Modification

Perform the following steps to modify the system to communicate with the tape drive:

1. From the command line, type:

```
cd /kernel/drv
```

2. Edit the “**st.conf**” file by adding the following before the first occurrence of “name=”:

```
# entry for TLZ06 tape drive
tape-config-list = "DEC^^^^^TLZ06",
" DEC 2GB 4mm Helical Scan", "TLZ06-data";
TLZ06-data = 1,0x34,0,0x1639,4,0xfd,0xfd,0xfe,0xfe,3;
```

where:

In the “**tape-config-list**” parameter:

- The first parameter (DEC^^^^^TLZ06) is the parameter returned by the tape drive on a SCSI inquiry command. (There should be five spaces between “DEC” and “TLZ06” elements.)
- The second parameter (DEC 2GB 4mm Helical Scan) is a *nickname* for the tape drive.
- The third parameter is defined as follows:

In the “TLZ06-data” string:

- The first parameter (1) is the revision level of the software and is set to 1.
- The second parameter (0x34) is the tape type, specifying “other” tape drive. (This is defined in /usr/include/sys/mtio.h.)
- The third parameter (0) is the block size in bytes.
- The fourth parameter (0x1639) defines the options selected. The 0x1639 value represents the following options:

ST_VARIABLE	= 0x0001
ST_BSF	= 0x0008
ST_BSR	= 0x0010
ST_LONG_ERASE	= 0x0020
ST_KNOWS_EOD	= 0x0200
ST_UNLOADABLE	= 0x0400
ST_LONG TIMEOUTS	= 0x1000
- The fifth parameter (4) defines the number of densities. The maximum definable number of densities is 4.*
- The sixth through ninth parameters (0xfd, 0xfd, 0xfe, 0xfe) comprise the density codes (low_hi) as defined below:
 - 0xfd is the vendor-unique density code for the tape in the *uncompressed* mode (2.0 GB).
 - 0xfe is the vendor-unique density code for the tape in the *compressed* mode (4.0 GB).
- The last parameter in the data string is the default density of 3 for the tape in the compressed mode.

*This maximum definable number of densities is a Sun Operating System limitation.

B.3.1.2 System Shutdown

After you have edited the “**st.conf**” file, shut down the system as follows:

```
sync
cd /
shutdown -i0 -g0 -y
```

B.3.1.3 Installation of the Tape Drive

Install the tape drive into the storage subsystem and power on the workstation. We recommend that the tape drive’s SCSI device address be set to ID 4 or to ID 5.

NOTE

If your SCSI host adapter is supported by the “`probe-scsi`” command, then you can use this command at the boot prompt to verify that the connected device is correctly attached to the system.

B.3.1.4 Rebooting of System

Reboot the system using the following command at the boot prompt:

```
>boot -rv
```

Note that the switch “**r**” forces the kernel to be re-configured, and switch “**v**” enables a display of the system configuration at boot time.

The system compiles the kernel and creates special files in **/dev** so that it can communicate with the tape drive. Since you booted the system using the verbose switch, the system displays all of its SCSI targets. Verify that “DEC 2GB 4mm Helical Scan” is displayed as a target when the system is booting.

At this time, the tape drive is configured in the **/dev** directory in two ways: **rmt** format, and **rst** format.

“rmt” format

In this format, the drive is configured with various options. For further explanations, see the man pages on “**st**” (the modes are *x*, *xl*, *xm*, *xh*, *xc*, and *xu*, where *x* is the **rmt** number).

- Options *x*, *xh*, *xu*, and *xc*, correspond to the **0xfe** density mode (*compressed* format).
- Options *xl* and *xm* correspond to the **0xfd** density mode (*uncompressed* format).
- Option *b* associates with the BSD behavior and is for backward compatibility on all of the above options. For further information, refer to the man pages of “**mtio**”.

The *n* option provides access to the device with **no rewind**, similar to **nrst** (below), and is also applicable to all of the above options.

“rst” format

Special files “**rst**” (rewind on close) and “**nrst**” (no rewind on close) are also built and reside in the **/dev** directory. For example, if the SCSI target ID for the tape drive is 4 and the drive is connected to the native SCSI bus, then “**rst**” will be “**rst4**, **rst12**, **rst20**, and **rst28**” and **nrst** will be “**nrst4**, **nrst12**, **nrst20**, and **nrst28**”.

- *rst4* and *nrst4* correspond to the 0xfd density mode (*uncompressed* format)
- *rst12* and *nrst12* correspond to the 0xfd density mode (*uncompressed* format)
- *rst20* and *nrst20* correspond to the 0xfe density mode (*compressed* format)
- *rst28* and *nrst28* correspond to the 0xfe density mode (*compressed* format)

B.3.1.5 Test

To test the tape drive, back up the “**passwd**” file to tape using the “tar” command, as follows:

```
tar cvf /dev/rst4 /etc/passwd
```

The system responds with:

```
a /etc/passwd 1 blocks
```

Note that, depending on the size of the file, a different number of blocks may be reported.

B.3.1.6 Verification

Verify that the “**passwd**” file was saved to tape using the following command:

```
tar tvf /dev/rst4
```

The system responds with

```
rw-r--r-- 0/10 535 Mar 23 16:31 1994 /etc/passwd
```

The installation and verification procedure is now complete.

B.3.2 Dump Parameters for the Tape Drive

The parameters that should be used when running the **ufsdump** utility with the tape drive are as follows:

density (d) = 61000 (BPI)

blocking factor = 126

Example,

The following parameter is an example of the command for backing up an entire disk partition (/dev/rdisk/c0t3d0s6) onto the tape drive:

```
ufsdump 0dbfo 61000 126 /dev/rmt2 /dev/rdisk/c0t3d0s6
```



Product Notes for Novell™, MS-DOS™, and Windows NT™

This appendix provides information for the system administrator. It should be read before installing and using the SWXTA-AA tape drive SBB with a host system operating under the Novell, MS-DOS, or MS-DOS/WINDOWS operating systems.

C.1 Host SCSI Interface

The SWXTA-AA tape drive SBB utilizes the standard SCSI-2 command set to interface to the PC-based host system. Thus, the host system must be equipped with a SCSI adapter to properly interface the tape drive with the host. For example, the host SCSI adapter might interface the computer's EISA bus to the SCSI-2 port of the SBB.

A host PC SCSI adapter is normally supplied with a compatible software driver for use with its operating system. When operating under the Novell and MS-DOS or MS-DOS/WINDOWS operating systems, the software driver must be pre-loaded according to the SCSI adapter manufacturer's installation procedure to ensure a proper interface between the tape drive SBB and the host. In addition, a user-level tape read/write software program may be required to implement tape support under the Novell, MS-DOS, MS-DOS/WINDOWS™ or WINDOWS NT™ environments. There are many commercial software products available that provide host or network-based data backup and restore, archiving, data logging, etc. functionality for these operating systems.

The SWXTA-AA tape drive is supported under WINDOWS NT 3.1 and 3.5 by adding the "4 millimeter DAT drive" tape device option. Follow the WINDOWS NT "Add/Remove Tape Devices" procedure to add this support. WINDOWS NT does not currently support the SWXTA-LA autoloader SBB.

Before purchasing a user-level software product, ensure that the tape drive SBB is supported by that product (see note below). Commercial software vendors usually publish a supported hardware list, or have telephone technical support personnel that will answer questions regarding compatibility of a particular tape drive or other storage devices. When choosing a software product suitable for your application, follow the software vendor's installation procedure to implement support for your tape drive SBB.

NetWare™ is a trademark of Novell, Inc.

Microsoft® is a registered trademark of Microsoft Corporation.

MS-DOS™ and Windows™ are trademarks of Microsoft Corporation.

Novell™ is a tradename of Novell, Inc.

Finally, if your host is operating under Novell Netware™, Novell, Inc. provides a software product called "Server Backup" with some of its operating system products. This program has been found to work well with the SWXTA-AA tape drive SBB. The SWXTA-LA auto loader is not supported with this software product.

NOTE

The SWXTA-AA tape drive SBB is functionally equivalent to the TLZ06 (DEC part no.) tape drive. Although commercial software products that support the TLZ06 will also support the SWXTA-AA, the TLZ06 unit has the compression mode turned off as a default. The SWXTA-AA is supplied with the compression mode enabled.

Reader's Comments

Manual Order Number:

EK-SM2TA-UG. C01

StorageWorks 4-mm DAT Tape Drive/Autoloader SBBs

Digital is committed to providing the best possible products and services. Since our manuals are important components of our products, we value your comments, corrections, and suggestions for improvements. Please take a few minutes to fill out and return this form, attaching additional sheets, if needed. Thank you.

Manual Rating

Accuracy (correct presentation of facts)

Excellent

Good

Fair

Poor

[]

[]

[]

[]

Completeness (adequate information)

[]

[]

[]

[]

Clarity (easy to understand)

[]

[]

[]

[]

Organization (logical sequence of information)

[]

[]

[]

[]

Layout (easy to follow subject matter)

[]

[]

[]

[]

Indexing (easy to locate desired information)

[]

[]

[]

[]

Errors Noted (please include page, paragraph, table or figure number)

Most-Liked Features

Least-Liked Features

Suggestions for Improvement

Return Address:

Digital Equipment Corporation
Customer Research
Response Center
ATTN: Nan Andrews Amish
334 South Street, SHR3-2/S27
Shrewsbury, MA 01545

Name

Phone

Title

Company

Street Address

Mail Stop

City

State

ZIP

Country (if other than USA)

digital™

Printed in U.S.A.