

DIGITAL GIGAswitch/Ethernet System

Installation and Operation Guide

Part Number: EK-DGBGA-IN. A01

February 1998

This guide explains how to install, configure, and operate the GIGAswitch/Ethernet system.

Revision/Update Information:	This is a new document.
Firmware Version:	V1.0

Digital Equipment Corporation makes no representations that the use of its products in the manner described in this publication will not infringe on existing or future patent rights, nor do the descriptions contained in this publication imply the granting of licenses to make, use, or sell equipment or software in accordance with the description.

Possession, use, or copying of the software described in this publication is authorized only pursuant to a valid written license from DIGITAL or an authorized sublicensor.

© Digital Equipment Corporation 1998. All rights reserved. Printed in U.S.A.

The following are trademarks of Digital Equipment Corporation: clearVISN, DIGITAL, the DIGITAL logo, and GIGAswitch.

Internet Explorer, Windows 95, and Windows NT are trademarks of Microsoft Corporation.

Netscape Navigator is a registered trademark of Netscape Communications Corporation.

UNIX is a registered trademark in the United States and other countries, licensed exclusively through X/Open Company Ltd.

All other trademarks and registered trademarks are the property of their respective holders.

FCC Notice — Class A Computing Device:

This equipment generates, uses, and may emit radio frequency energy. The equipment has been type tested and found to comply with the limits for a Class A digital device pursuant to Part 15 of FCC rules, which are designed to provide reasonable protection against such radio frequency interference. Operation of this equipment in a residential area may cause interference in which case the user at his own expense will be required to take whatever measures may be required to correct the interference. Any modifications to this device - unless expressly approved by the manufacturer - can void the user's authority to operate this equipment under part 15 of the FCC rules.

VCCI Notice — Class A Computing Device:

This equipment is in the Class A category (information equipment to be used in commercial and/or industrial areas) and conforms to the standards set by the Voluntary Control Council for Interference by Data Processing Equipment and Electronic Office Machines aimed at preventing radio interference in commercial and/or industrial areas. Consequently, when used in a residential area or in an adjacent area thereto, radio interference may be caused to radios and TV receivers. Read the instructions for correct handling.

CE Notice — Class A Computing Device:

Warning!

This is a Class A product. In a domestic environment, this product may cause radio interference, in which case the user may be required to take adequate measures.

Achtung!

Dieses ist ein Gerät der Funkstörgrenzwertklasse A. In Wohnbereichen können bei Betrieb dieses Gerätes Rundfunkstörungen auftreten, in welchen Fällen der Benutzer für entsprechende Gegenmaßnahmen verantwortlich ist.

Avertissement!

Cet appareil est un appareil de Classe A. Dans un environnement résidentiel cet appareil peut provoquer des brouillages radioélectriques. Dans ce cas, il peut être demandé à l'utilisateur de prendre les mesures appropriées.

警告使用者:

這是甲類的資訊產品，在居住的環境中使用時，可能會造成射頻干擾，在這種情況下，使用者會被要求採取某些適當的對策。

Contents

Preface

Overview	xi
Purpose of This Guide	xi
Intended Audience	xi
Organization	xii
Conventions	xiii
Overview	xiii
Correspondence	xiv
Documentation Comments	xiv
World Wide Web	xiv
How to Order Additional Documentation	xv

Safety

Overview	xvii
Precautions	xviii

1 Installing the GIGAswitch/Ethernet System

Overview	1-1
Introduction	1-1
In This Chapter	1-1
Unpacking the System	1-2
Checking Your Shipment	1-2
Selecting a Location	1-4
Installing the System	1-5
Preventing Electrostatic Discharge	1-5
Installing the Chassis	1-6
Rack Mounting the System	1-6
Installing the System on a Tabletop	1-8
Installing the Modules	1-9

Installing the Cables	1-10
Guidelines for Cable Distances	1-12
Making Sure That You Have Enough Power Available	1-13
Connecting the Power Supplies	1-14
Powering On the System	1-14
Power-On Sequence	1-14
Post Power-On Configuration	1-15
What to Do Next	1-15

2 Understanding the GIGAswitch/Ethernet System

Overview	2-1
Introduction	2-1
In This Chapter	2-1
What Is the GIGAswitch/Ethernet System?	2-2
Hardware Description	2-3
Chassis	2-3
Modules	2-4
Switch Control Processor	2-4
I/O Modules	2-4
Features	2-6
Crossbar Switch Fabric	2-6
Why It Matters	2-7
Features	2-7
Virtual Bridging Functions	2-7
Flood Pruning Using VLANs	2-8
Why It Matters	2-8
Features	2-8
Hunt Groups	2-10
Why They Matter	2-10
Features	2-10
Multilayer Spanning Trees	2-12
Why They Matter	2-12
Features	2-12
Extensive Fault Tolerance	2-13
Why It Matters	2-13
Features	2-13
Buffer and Queue Management	2-13
Why It Matters	2-13
Features	2-13
Web-Based Management	2-14
Why It Matters	2-14
General Features	2-14
Smart Web Agent	2-14

RMON for Traffic Analysis	2-14
Gigabit Ethernet MIB	2-14

3 Configuring the GIGAswitch/Ethernet System

Overview	3-1
Introduction	3-1
In This Chapter	3-1
What You Will Need	3-2
Connecting to the GIGAswitch/Ethernet System Web Agent	3-3
Configuring the Switch Using the Web Agent	3-6
Logging In to the Web Agent	3-7
Entering Basic System Information	3-8
Setting Up User Accounts	3-10
Configuring Port Parameters Using the Web Agent	3-12
Configuring Physical Port Parameters on Gigabit Ports	3-12
Configuring Physical Port Parameters on Fast Ethernet Ports	3-15
Using the All Module Ports Configuration Screen	3-18
Configuring Switch Port Parameters	3-19
Using the All Module Ports Configuration Screen	3-22
Setting Up SNMP Communities	3-23
Changing the Console Serial Port Settings	3-25
Setting Up the Information Server	3-26
Setting the Server Location	3-27

4 Tuning Your Network Using VLANs, Spanning Tree, and Hunt Groups

Overview	4-1
Introduction	4-1
In This Chapter	4-1
Using Virtual LANs	4-2
Why Use VLANs?	4-2
Creating and Implementing VLANs using the Web Agent	4-2
Creating a VLAN	4-3
Assigning Ports to VLANs	4-4
Using Spanning Tree Setup and Monitoring	4-5
Why Use Spanning Trees?	4-5
What Is a “Bridge” in a GIGAswitch/Ethernet System Spanning Tree?	4-5
What Are the Implications of a Multilayer Spanning Tree?	4-6
Managing Spanning Trees Using the Web Agent	4-7
Configuring All Ports on a Module for Spanning Tree Fast Start Mode	4-9

Configuring Spanning Tree Bridge Ports	4-10
Using Hunt Groups to Aggregate Bandwidth Between Switches	4-13
Why Use Hunt Groups?	4-13
What You Need to Know Before Configuring Hunt Groups	4-13
Configuring Hunt Groups Using the Embedded Web Server	4-14
Adding Ports to a Hunt Group	4-15

5 Tuning Your Switch Performance by Managing Buffers and Queues

Overview	5-1
Introduction	5-1
In This Chapter	5-1
Why Use Buffer Management?	5-2
How GIGAswitch/Ethernet System Queues Work	5-2
Managing Buffers and Queues	5-4
Additional Buffers on Fast Ethernet Ports	5-7

6 Managing Address Forwarding Tables

Overview	6-1
Introduction	6-1
In This Chapter	6-1
Configuring the Address Forwarding Table	6-2
Setting the Age Timer and Super Age Timer	6-2
Controlling Reconfiguration of Address Table Sizes	6-3
Viewing the Switch Address Forwarding Table	6-5
Displaying the Address Forwarding Table	6-5
Adding Entries to the Address Forwarding Table Manually	6-8

7 Monitoring GIGAswitch/Ethernet System Health

Overview	7-1
Introduction	7-1
In This Chapter	7-1
Interpreting Front Panel LED Displays	7-2
Checking Temperature Status and Setting Thresholds	7-3
Checking Active Alarms	7-5
Viewing the Active Alarm Table from the Web Agent	7-5
Setting Log Size and Activating System Events	7-6
Using the Switch Event and Shutdown Logs	7-9

8 Analyzing Network Performance Using RMON and Ethernet Statistics

Overview	8-1
Introduction.....	8-1
In This Chapter	8-1
Viewing Statistics	8-2
Intrepreting Statistics	8-6
Setting Up a Mirror Port	8-11

A Downloading GIGAswitch/Ethernet System Firmware

Overview	A-1
Introduction.....	A-1
In This Appendix	A-1
Upgrade Process.....	A-2
Preparing for the Download.....	A-3
Downloading the New Firmware.....	A-4

B Using the Command Line Interface

Overview	B-1
Introduction.....	B-1
In This Appendix	B-1
Interface Features.....	B-3
Using the Interface.....	B-4
Basic Keyboard Commands	B-5
Command Line History	B-5
Scripts	B-5
Help.....	B-5
Community.....	B-6
Console.....	B-8
Download.....	B-9
Event	B-10
Exit.....	B-11
Feprom.....	B-12
Module.....	B-13
Net	B-14
NVRAM.....	B-16
Pause	B-17
Ping	B-18
Port.....	B-19

Rtc	B-21
Setup	B-22
Stack	B-23
Telnet.....	B-24
User	B-25
Verbose	B-27
VLAN	B-28

C Product Specifications

Overview	C-1
Introduction	C-1
In This Appendix	C-1
Product Specifications.....	C-2
Acoustical Specifications	C-4

Index

Tables

1-1	Pinouts to 10BASE-T Cables	1-11
1-2	Pinouts to RS232 DB-9 Female Console Port	1-11
1-3	Maximum Fiber Link Distances for Gigabit Links	1-12
1-4	Maximum Fiber Link Distances for 100 Mb/s Links	1-12
1-5	Maximum Copper Cable Lengths (10/100 Mb/s Links)	1-12
1-6	Power Values for System Devices	1-13
1-7	Normal Power-Up LED Function.	1-15
3-1	Terminal Setup	3-2
3-2	Pinouts for 10BASE-T Crossover Patch Cables.	3-5
3-3	Default User Logins	3-10
3-4	User Account Access Levels	3-11
3-5	Gigabit Port Settable Attributes	3-12
3-6	10/100 Port Settable Attributes	3-15
3-7	VLAN Trunking Modes	3-20
3-8	Use of Incoming Frame VLAN Tags	3-21
3-9	VLAN Binding Options	3-21
3-10	SNMP Security Levels	3-24
3-11	Terminal Setting Options	3-25
4-1	Create VLAN Parameters.	4-4
4-2	Spanning Tree Types	4-7
5-1	Buffer Management Table Definitions.	5-6
6-1	Address Table Column Definitions	6-7
7-1	Front Panel LED Display Interpretation.	7-2
7-2	Temperature Thresholds.	7-4
7-3	Event and Shutdown Logs	7-7
7-4	Event Classes	7-7
7-5	Event Table Actions	7-8
7-6	Event and Shutdown Log Entries	7-10
8-1	Interpreting Ethernet Statistics	8-6
8-2	RMON Mirror Port Configuration Values	8-12
B-1	Command Line History Commands	B-5
C-1	Product Specifications	C-2
C-2	English Acoustical Specifications	C-4
C-3	German Acoustical Specifications	C-4

Preface

Overview

Purpose of This Guide

This guide describes how to install, initially configure, and operate the DIGITAL GIGAswitch/Ethernet system. It also provides information about advanced configuration options.

Intended Audience

This guide is intended for use by individuals responsible for installing, configuring, or operating the GIGAswitch/Ethernet system.

Organization

This guide is organized as follows:

Section	Description
Chapter 1	Describes how to unpack, select a location for, and install the GIGAswitch/Ethernet system.
Chapter 2	Provides an overview of the system's hardware and functions.
Chapter 3	Describes how to initially set up and configure the system.
Chapter 4	Describes how to use the GIGAswitch/Ethernet system and VLANs, spanning tree, and hunt groups to tune your network.
Chapter 5	Describes how to use buffer and queue management to tune the system's performance.
Chapter 6	Describes how to manage address forwarding tables in the system.
Chapter 7	Describes how to assess the system's current operational status.
Chapter 8	Describes how to analyzing network performance using RMON and Ethernet statistics.
Appendix A	Describes how to download firmware to the system.
Appendix B	Describes how to use the system's command line interface.
Appendix C	Lists the system's specifications.

Conventions

Overview

This guide uses the following conventions:

Convention	Description
Special Type	This special type in examples indicates system output.
Boldface	Boldface type in procedures and examples indicates user input.
Ctrl- <i>x</i>	Ctrl- <i>x</i> indicates that you hold down the Ctrl key while you press another key (indicated here by <i>x</i>).

Correspondence

Documentation Comments

If you have comments or suggestions about this guide, send them to DIGITAL Network Products:

Attn.: Documentation Project Manager
E-MAIL: doc_feedback@lkg.mts.dec.com

World Wide Web

To locate product-specific information, refer to the DIGITAL Network Products Home Page on the World Wide Web at the following locations:

North America: <http://www.networks.digital.com>

Europe: <http://www.networks.europe.digital.com>

Asia Pacific: <http://www.networks.digital.com.au>

Follow the Technical Information link to firmware, manuals, and more for the GIGAswitch/Ethernet system.

How to Order Additional Documentation

To order additional documentation, use the following information:

To Order:	Contact:
By Telephone	USA (except Alaska, New Hampshire, and Hawaii): 1-800-DIGITAL (1-800-344-4825) Alaska, New Hampshire, and Hawaii: 1-603-884-6660 Canada: 1-800-267-6215
Electronically (USA. only)	Dial 1-800-DEC-DEMO (For assistance, call 1-800-DIGITAL)
By Mail (USA and Puerto Rico)	DIGITAL EQUIPMENT CORPORATION P.O. Box CS2008 Nashua, New Hampshire 03061 (Place prepaid orders from Puerto Rico with the local Digital subsidiary: 809-754-7575)
By Mail (Canada)	DIGITAL EQUIPMENT of CANADA LTD. 940 Belfast Road Ottawa, Ontario, Canada K1G 4C2 Attn.: A&SG Business Manager
Internationally	DIGITAL EQUIPMENT CORPORATION Attn.: A&SG Business Manager c/o local Digital subsidiary or approved distributor
Internally	U.S. Software Supply Business (SSB) DIGITAL EQUIPMENT CORPORATION 8 Cotton Road Nashua, New Hampshire 03063

Safety

Overview

Any warning or caution that appears in this guide is defined as follows. The cautions that must be observed for the hardware described in this guide are listed below in English, German, French, and Spanish.

WARNING	Contains information to prevent personal injury.
CAUTION	Contains information to prevent damage to equipment.
VORSICHT	Enthält Informationen, die beachtet werden müssen um den Benutzer vor Schaden zu bewahren.
ACHTUNG	Enthält Informationen, die beachtet werden müssen um die Geräte vor Schaden zu bewahren.
DANGER	Signale les informations destinées à prévenir les accidents corporels.
ATTENTION	Signale les informations destinées à prévenir la détérioration du matériel.
AVISO	Contiene información para evitar daños personales.
PRECAUCIÓN	Contiene información para evitar daños al equipo.

Precautions

WARNING	A fully loaded system weighs 30 kg (65 lb). Safe rackmount installation requires three people: two to lift the system into place, and a third to screw the system to the rack.
VORSICHT	Ein voll beladenes System wiegt 30Kg. Zur Sicherheit sollten bei der Gestellmontage drei Personen anwesend sein: zwei Personen, um das System anzuheben und zu positionieren, und eine dritte Person, um das eingehängte System festzuschrauben.
DANGER	Le poids total d'un système monté avec toutes les cartes qu'il peut recevoir est de 30 kg. Pour installer un système sur un rack en toute sécurité, il convient de faire appel à trois personnes : deux personnes pour mettre le système en place et une troisième personne pour le fixer sur le rack.
AVISO	Un sistema de carga completa pesa 30 kg. La instalación de la carcasa montada en bastidor requiere tres personas: dos para levantar el sistema y una para atornillar el sistema al soporte.

CAUTION	This action deletes all configured settings and replaces them with factory default values. All configuration settings will be lost.
ACHTUNG	Bei diesem Vorgang werden alle Konfigurationseinstellungen gelöscht und die Werkseinstellungen wieder eingesetzt. Alle Konfigurationsdaten gehen verloren.
ATTENTION	Cette action supprime tous les paramètres de configuration et les remplace par des valeurs prédéfinies. Tous les paramètres de configuration seront perdus.
PRECAUCIÓN	Esta intervención borrará todos los parámetros de configuración y los sustituirá por valores por defecto definidos de fábrica. Se perderán todos los parámetros de configuración.

Precautions

CAUTION	Static electricity can damage modules and electronic components. DIGITAL recommends using a grounded antistatic wrist strap and a grounded work surface when handling any modules.
ACHTUNG	Module und elektronische Komponenten können durch elektrostatische Entladungen beschädigt werden. Benutzen Sie immer eine antistatische Gelenkmanschette und eine geerdete Arbeitsunterlage, wenn Sie am offenen Gerät arbeiten.
ATTENTION	Les charges excessives d'électricité statique peuvent endommager les modules et les composants électroniques. DIGITAL conseille l'utilisation d'un bracelet de masse et d'un plan de travail mis à la terre lors de la manipulation des modules.
PRECAUCION	La electricidad estática puede dañar los componentes electrónicos y los módulos. DIGITAL recomienda que se utilicen cintas de pasadores y superficies de trabajo conectadas a tierra al trabajar con cualquier módulo.

Chapter 1

Installing the GIGAswitch/Ethernet System

Overview

Introduction

This chapter describes how to install the DIGITAL GIGAswitch/Ethernet system. It contains important information to protect both you and the system during installation.

In This Chapter

This chapter contains the following topics:

Topic	Page
Unpacking the System	1-2
Selecting a Location	1-4
Installing the System	1-5

Unpacking the System

Checking Your Shipment

To check your shipment:

Step	Action
1	Unpack the shipping cartons. When removing the system chassis from its carton: <ul style="list-style-type: none">a) Carefully set the carton on its side.b) Slide the chassis out of the carton. <p><u>Note:</u> Do not use the handles on the system to lift the chassis.</p>
2	Check that you have all the items you need to install the system:

Chassis

Power supply

Switch control processor module

Fan tray

Five blank faceplates

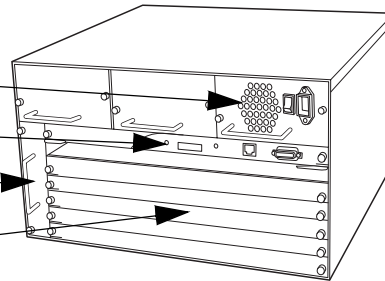

Documentation

Letter
Release notes
Quick start guide
Information library CD

Installation Kits

Rackmount kit
Rubber feet for tabletop installation

Unpacking the System

Step	Action
	Cables and Connectors <ul style="list-style-type: none">• Power cord• 10BASE-T crossover cable (connects to the Ethernet console port)• Out-of-band connection kit:<ul style="list-style-type: none">— Male DCE-to-RJ45 connector (marked MDCE) for connecting to the switch— Female DTE-to-RJ45 connector (marked FDTE) for connecting to your computer— Male DTE-to-RJ45 null modem connector (marked DTE XOVER) for connecting to a modem— Straight-through RJ45 cable (connects between the connectors)
	Options as ordered (shipped in separate cartons) <ul style="list-style-type: none">• I/O modules• Additional power supplies
3	Unpack the shipment and report any lost or damaged items to your shipping carrier, DIGITAL representative, or distributor.

Selecting a Location

The location you select for installing the system hardware must meet the following requirements:

- 19-inch, EIA-standard, grounded rack or table capable of supporting at least 60 kg (130 lb). A fully loaded switch weighs 30 kg (65 lb).
- At least 5.2 cm (2 in) on either side of the system, and from the rear of the system, to allow adequate airflow through the system.

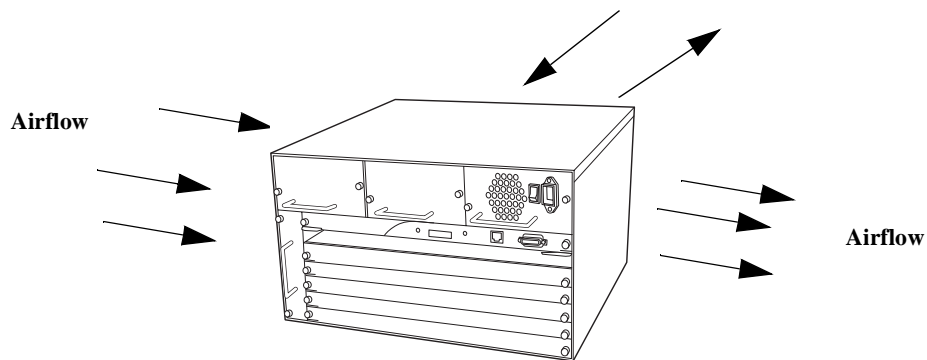

- AC power source(s) within 2 m (6 ft) (separate sources, on separate circuits, if you require maximum fault tolerance).
- Ambient temperature between 0°C and 40°C (32°F to 104°F).
- Relative humidity less than 95%, noncondensing.

Installing the System

The process for installing the system requires the following tasks:

- 1) [Preventing Electrostatic Discharge](#)
- 2) [Installing the Chassis](#)
- 3) [Installing the Modules](#)
- 4) [Installing the Cables](#)
- 5) [Making Sure That You Have Enough Power Available](#)
- 6) [Connecting the Power Supplies](#)
- 7) [Powering On the System](#)

Preventing Electrostatic Discharge

Protect the modules against damage from electrostatic discharge (ESD) by using a grounded ESD wrist strap while installing and removing modules. A Portable Static-Dissipative Field Service Kit, part number 29-26246, is available through your DIGITAL representative or distributor.

While installing the GIGAswitch/Ethernet system:

Step	Action
1	Ground the unit. The unit is grounded through the power cord when it is connected between the unit and the primary power source.
2	Lay out the static-dissipative work surface (ESD mat) on a flat surface.
3	Connect the ground cord assembly to the ESD mat and to the ground plug on the switch fan tray. <u>Note:</u> The ground plug accepts a ground cord with a banana plug, or a screw to which you can connect a ground cord clip.
4	Wear the ESD wrist strap and attach it to the ground cord assembly.

Installing the System

Installing the Chassis

The system can be installed by:

- [Rack Mounting the System](#)
- [Installing the System on a Tabletop](#)

Rack Mounting the System

WARNING

A fully loaded system weighs 30 kg (65 lb). Safe rackmount installation requires three people: two to lift the system into place, and a third to screw the system to the rack.

NOTE

Do not use the handles on the power supplies or fan assembly to lift the system.

To rack mount the system, you will need a Phillips-head screwdriver:

Step	Action
1	Install the rackmount flanges onto the system with the supplied screws.

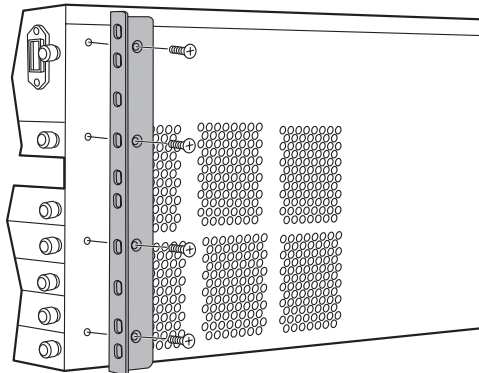

Installing the System

Step	Action
2	<p data-bbox="467 590 1089 619">Check that all pre-installed modules are securely installed:</p> <ul data-bbox="467 632 1219 772" style="list-style-type: none"><li data-bbox="467 632 1122 661">• Check that the switch control processor is firmly installed.<li data-bbox="467 674 1122 703">• Check that the power supply and fan are securely in place.<li data-bbox="467 716 1219 772">• Tighten the large black screws on the module, power supply, and fan tray faceplates.
3	<p data-bbox="467 793 1219 852">With one person at each end of the system, lift the system into position. Install the system into the rack using screws appropriate for your rack.</p>

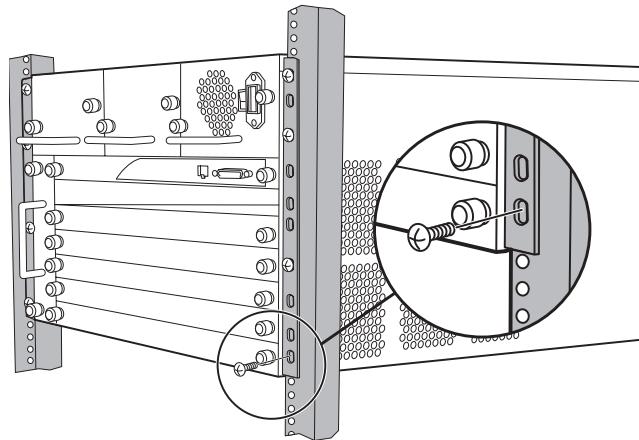

Installing the System

Installing the System on a Tabletop

NOTE

Do not use the handles on the power supplies or fan assembly to lift the system.

To install the system on a tabletop:

Step	Action
1	Place the system on a surface that supports at least 90 kg (200 lb).
2	Apply the supplied rubber feet to the bottom of the unit, placing the feet about 1.3 cm (1/2 in) from each corner of the unit.

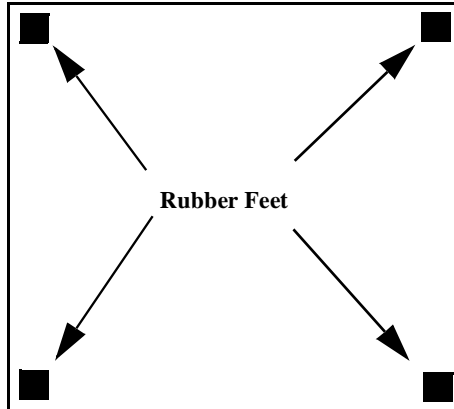

- 3 Check that all pre-installed modules are securely installed:
- Check that the switch control processor is firmly installed.
 - Check that the power supply and fan are securely in place.
 - Tighten the large black screws on the module, power supply, and fan tray faceplates.
-

Installing the Modules

CAUTION

Static electricity can damage modules and electronic components. DIGITAL recommends using a grounded antistatic wrist strap and a grounded work surface when handling any modules.

To install modules in the system chassis:

Step	Action
1	Carefully remove each module from its box, leaving each module in its antistatic wrapping.
2	After taking appropriate antistatic precautions, as described in Preventing Electrostatic Discharge on page 1-5 , carefully remove the module from the antistatic wrap.
3	Insert the module into the system as shown below:

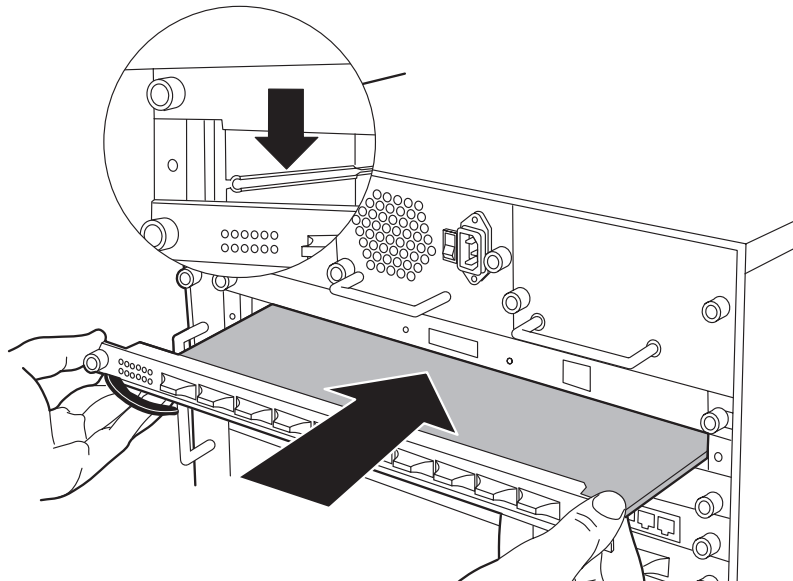

Installing the System

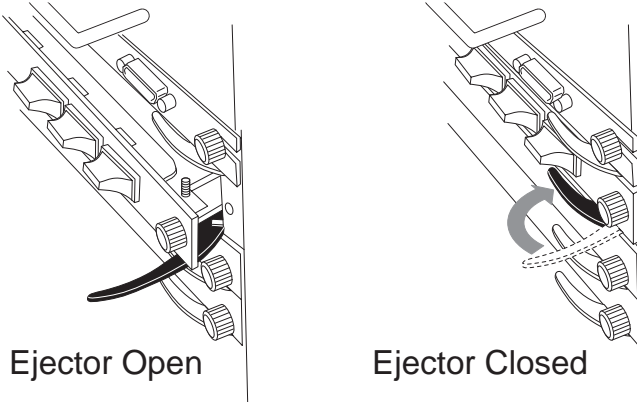
Step	Action
4	Push the module all the way into the system chassis, then use the ejectors to lock the module into the system backplane as shown below:
	
5	Tighten the black captive screws.
6	Repeat steps 2 through 5 for each additional module that you are installing. <u>Note:</u> Use a Phillips screwdriver to remove faceplates covering additional module slots in the system.

Installing the Cables

Install appropriate cables for your network configuration. GIGAswitch/Ethernet systems use the following cable types:

- Fiber cables with SC-type connectors.
- Straight-through Category 5 cables with male RJ45 connectors (end station/NIC card connections). All I/O ports are crossed over internally, so you can use straight-through cables to attach to end stations, and crossover cables to attach to repeaters.
- Crossover cables with male RJ45 connectors (switch-to-switch connections).

Table 1-1: Pinouts to 10BASE-T Cables

Pin	Signal Description
1	Receive data (+)
2	Receive data (-)
3	Transmit data (+)
4	Not used
5	Not used
6	Transmit data (-)
7	Not used
8	Not used

Table 1-2: Pinouts to RS232 DB-9 Female Console Port

Pin	Signal Description
1	DCD (output)
2	TX (output)
3	RX (input)
4	DTR (input)
5	SGD (ground)
6	DSR (not used)
7	RTS (not used)
8	CTS (output)
9	RI (not used)

Installing the System

Guidelines for Cable Distances

NOTE

These figures describe maximum link distances only. When building half-duplex networks using Ethernet repeaters, you must also consider maximum network diameter, which is not discussed in this guide.

Table 1-3: Maximum Fiber Link Distances for Gigabit Links*

Fiber Cable Description		Maximum Cable Length
1300 nm	50 micron multimode	550 m
	62.5 micron multimode	440 m
	Singlemode fiber	3 km
850 nm	50 micron multimode	550 m
	62.5 micron multimode	260 m

*These guidelines are based on IEEE 802.3z Draft Document, version 3.2.

Table 1-4: Maximum Fiber Link Distances for 100 Mb/s Links

Fiber Cable Description	Maximum Cable Length
Half-duplex connection	412 m
Full-duplex connection	2 km

Table 1-5: Maximum Copper Cable Lengths (10/100 Mb/s Links)

Cable Description	Maximum Cable Length
Category 5 twisted pair cable	100 m

Making Sure That You Have Enough Power Available

Each power supply powers approximately three I/O modules. It takes two power supplies to power a full chassis. Using three power supplies ensures that the system has fault-tolerant, load-sharing power capabilities.

The precise values are:

Table 1-6: Power Values for System Devices

Device	Power Added/Used
Power supply	+400 W
Backplane elements	-50 W
20-port 10/100 module	-70 W
Switch control processor	-10 W
2-port gigabit module	-35 W
4-port gigabit module	-55 W
10-port 100BASE-FX module	-50 W

NOTE

See the instruction sheet included with the power supply for power supply installation instructions.

Installing the System

Connecting the Power Supplies

Before connecting the power cords:

- Make sure that all of the power supplies are seated firmly, with the captive screws tightened.
- Make sure that all of the ON/OFF switches on the power supplies are OFF.
- If you are using multiple power supplies to ensure fault tolerance, make sure that there is a dedicated power circuit available for each supply. The separate power sources help ensure operation when the power source itself fails.

To connect the power supplies:

Step	Action
1	Plug the power cord into each power supply.
2	Plug the power cord into an ac outlet.

NOTE

Do not wrap power cords through the handles on the system. Dressing the cords this way can interfere with hotswapping options in the system.

Powering On the System

To power on the system:

Step	Action
1	Check all connections.
2	Turn the power supplies on by switching on the power switches on each supply.

Power-On Sequence

As the system powers on, you will observe:

- On the 8-character LED display, the following message displays:
Digital GIGAswitch/Ethernet Agent v1.x.x
- On properly functioning modules, Port LEDs cycle from yellow to normal operating status as the system continues through its power-on diagnostics.

Installing the System

When the system has completed running its internal diagnostics:

- The 8-character LED display should read:
`Digital GIGAswitch/Ethernet Agent v1.x.x.`
- The LEDs should function as described in [Chapter 7](#). In general, you will observe the following on properly functioning modules:

Table 1-7: Normal Power-Up LED Function

Module	LED	Behavior
All modules	ModuleStatus ◀	Solid green, indicating normal operation.
Gigabit modules	TX and RX	Solid green, flashing yellow intermittently to indicate traffic.
	Port	Solid green, indicating link integrity. Inactive port LEDs will go off.
	HD/FD	Solid green, indicating full-duplex operation.
10/100 modules	Port	Solid green, flashing yellow intermittently to indicate traffic. Inactive port LEDs will go off.

NOTE

Contact your DIGITAL service representative if your system fails to function properly.

Post Power-On Configuration

The system is now fully operational as an 802.1d spanning tree-compliant bridge. All ports are assigned to a single VLAN (Default). What this means:

- All ports can send traffic to all other ports in the system without using a router.
- The system is a single flood domain, so all broadcast and unknown unicast traffic will be forwarded to all ports in the system.

What to Do Next

If you are familiar with the features of the GIGAswitch/Ethernet system and have installed and configured other GIGAswitch/Ethernet systems, proceed to [Chapter 3](#) to configure the system. Otherwise, proceed to [Chapter 2](#) to learn more about the system.

Chapter 2

Understanding the GIGAswitch/Ethernet System

Overview

Introduction

This chapter provides an overview of DIGITAL GIGAswitch/Ethernet system. It describes the switch chassis and modules, and the switch's advanced functions.

In This Chapter

This chapter contains the following topics:

Topic	Page
What Is the GIGAswitch/Ethernet System?	2-2
Hardware Description	2-3
Features	2-6

What Is the GIGAswitch/Ethernet System?

What Is the GIGAswitch/Ethernet System?

The GIGAswitch/Ethernet system is the first member in a family of Gigabit Ethernet switching products from DIGITAL. It supports the requirements of the next wave of networking: more bandwidth, elimination of bottlenecks, better manageability, and dependable multimedia support.

The GIGAswitch/Ethernet system offers an unrivaled combination of capacity and scalability in an extensive, top-to-bottom, fault-tolerant architecture with no single point of failure and advanced Class of Service/Quality of Service (CoS/QoS) features. It can be used in the campus backbone and in high-performance workgroup environments.

Hardware Description

This section gives a brief overview of the system's hardware features:

- [Chassis](#)
- [Modules](#)

Chassis

The chassis has the following features:

- Up to 3 power supplies
- Seven slots (six payload slots)
- Up to 120 10/100BASE-TX ports (autonegotiating)
- Up to 60 100BASE-FX ports
- Up to 24 gigabit-speed Ethernet ports

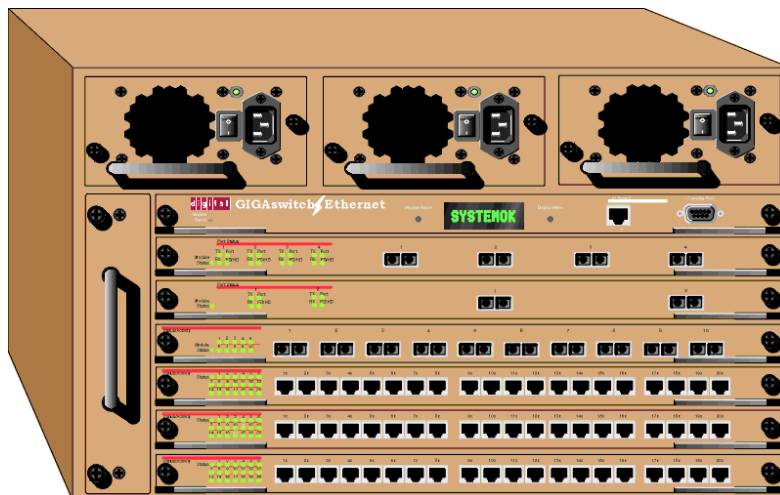

Hardware Description

Modules

The chassis supports the following modules:

- [Switch Control Processor](#)
- [Fast Ethernet Modules](#)
- [Gigabit-Speed Modules](#)

Switch Control Processor

Not involved in packet switching, the switch control processor (SCP) has the following features:

- PowerPC 860 RISC processor
- Memory: 4 MB Flash, 8 MB DRAM, 128 KB NVRAM
- Real-time clock
- Out-of-band console: 10BASE-T and RS-232
- RMON support
- SNMP management agent
- Dot matrix display



The switch control processor is responsible for address learning, address cache management, and spanning tree management.

I/O Modules

All I/O modules have full non-blocking performance (except for the economical 4-port gigabit module, which could experience temporary blocking at highest loads [in excess of 89% capacity, sustained, on two ports that share a single switch matrix port]). The modules all have the following features:

- **IEEE 802.3x full-duplex flow control.** This allows the switch ports to send a pause command before input buffers overflow. Half-duplex ports support active backpressure (jamming).
- **Priority Queuing and Class of Service.** These features allow you to prioritize traffic between particular stations or sets of stations to support jitter-sensitive applications.

Hardware Description

Fast Ethernet Modules

- **20-Port 10/100BASE-TX Ethernet Module**, with 20 RJ45 Ports - 10/100, HDX/FDX



- **10-Port 100BASE-FX Ethernet Module**, with 10 Fast Ethernet Ports - Fiber, 1300 nM, HDX/FDX



Gigabit-Speed Modules

- **2-Port, Full-Duplex 1000BASE-X module**: 850 nM (SX) and 1300 nM (LX)

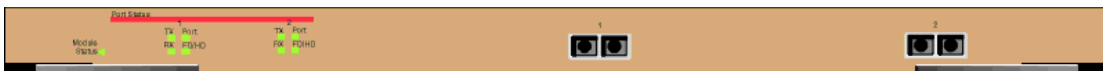

- **4-Port, Full-Duplex 1000BASE-X module**, 850 nM (SX)



Features

This section describes the following switch features:

- [Crossbar Switch Fabric](#)
- [Virtual Bridging Functions](#)
- [Flood Pruning Using VLANs](#)
- [Hunt Groups](#)
- [Multilayer Spanning Trees](#)
- [Extensive Fault Tolerance](#)
- [Buffer and Queue Management](#)
- [Web-Based Management](#)

Crossbar Switch Fabric

The crossbar switch matrix provides low-latency, high-throughput packet switching using a crossbar architecture.

GIGAswitch/Ethernet System Crossbar

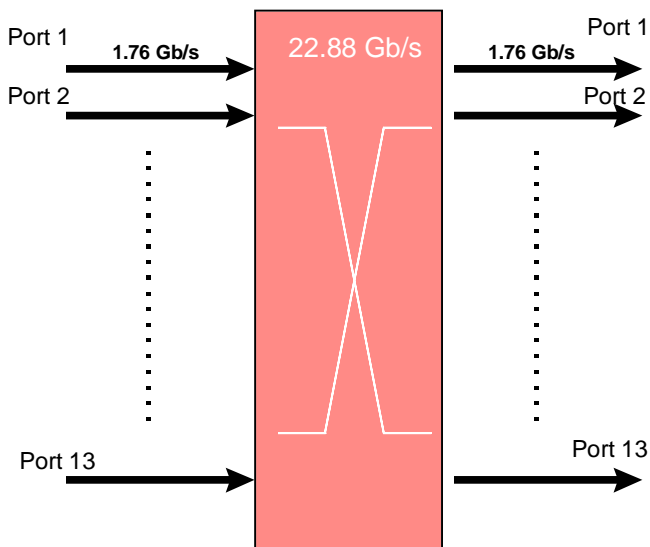

Why It Matters

Crossbars are inherently more scalable than shared memory architectures. Architecturally, you can add more capacity simply by adding more switch elements. By comparison, shared memory switches have an inherent maximum upper boundary in throughput that makes high-density, single-backplane gigabit switches impractical. This means that as you increase the number of gigabit ports in your network, the architecture can scale to meet your needs.

Features

The crossbar supports:

- 13 fabric ports (two per module slot, plus one for the switch control processor)
- 1.76 Gb/s (in and out/full-duplex) on each fabric port
- 22.88 Gb/s total capacity, 45.76 Gb/s total backplane capacity
- Under-subscribed switching fabric in most configurations (4-port gigabit modules are slightly oversubscribed)
- Single copy replication: When possible, input frames destined for output multiple switch ports pass through the crossbar only once and are copied by the crossbar to each destination.
- Hardware-assisted multicast pruning: The switch forwards only to appropriate destination switch ports.

Virtual Bridging Functions

The switch design supports:

- Over 16,000 MAC addresses in the switch address forwarding table. This feature allows the switch to store forwarding information for hosts in very large networks.
- Segmented address tables qualified by address and VLAN membership. This feature allows the same host to appear on different VLANs on different ports.
- Optional per-VLAN spanning tree. This isolates loop control to smaller domains, so spanning trees converge faster during reconfiguration.

Features

Flood Pruning Using VLANs

Why It Matters

Virtual LANs provide network managers with two significant capabilities:

- The ability to segment traffic in a “flat” switched network. This helps prevent traffic from being forwarded to stations where it is not needed.
- The ability to ignore physical switch locations when creating workgroups. VLANs are logical constructions and can traverse physical switch boundaries.

Features

The GIGAswitch/Ethernet system-based VLANs have the following characteristics:

- Frames classified by switch port.
- Explicitly tagged VLAN packets are forwarded based on the information in the packet.
- Up to 1024 VLANs: VLANs define a set of ports in a flooding domain. Packets that need to be flooded are sent only to ports participating in that VLAN.

Frame Classification in the GIGAswitch/Ethernet System

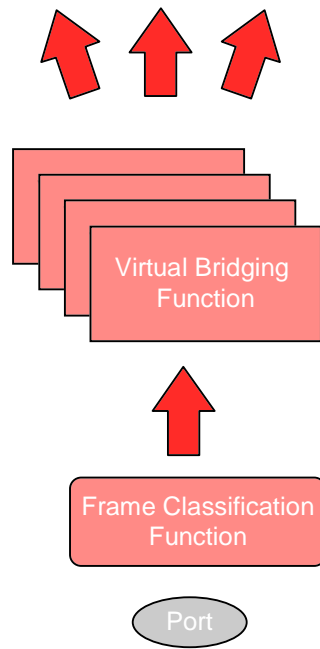

Features

Hunt Groups

Why They Matter

Hunt groups aggregate bandwidth from multiple ports so they act as one high-bandwidth switch port. Hunt groups allow you to create multi-gigabit pipes to transport traffic through the highest traffic areas of your network.

Features

A hunt group provides:

- Shared traffic load.
- Address-based traffic sorting, which keeps packets in the right order.
- Fault tolerance. If a port in a group fails, the remaining ports in the group pick up the traffic load.
- Support for any number of same-speed connections in a group. The group is not restricted to a single module in a switch.
- Quick recovery from link failure: If a port in the group fails, the remaining ports can carry the load. Recovery is not limited by spanning tree convergence time (convergence time is the time the network takes to resume steady-state forwarding after spanning tree reconfiguration).
- Up to 15 hunt groups per switch.

As shown in the following diagram, hunt groups can be set up to interoperate between GIGAswitch/Ethernet systems.

Example of GIGAswitch/Ethernet System Hunt Group

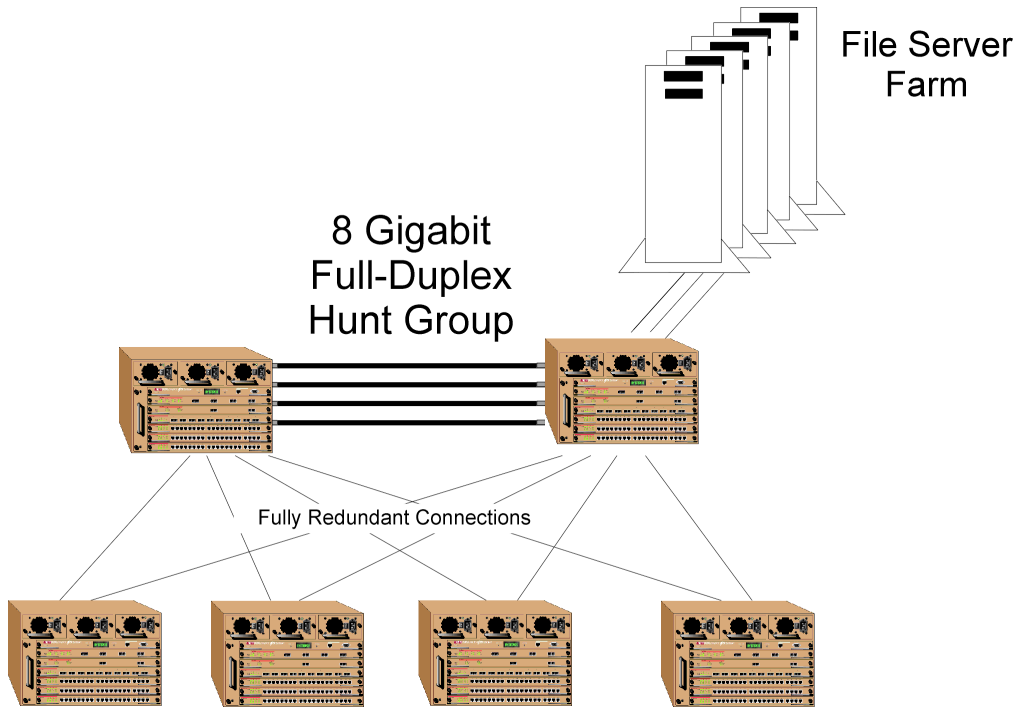

Features

Multilayer Spanning Trees

Why They Matter

Multilayer spanning trees provide two very important capabilities:

- Smaller spanning tree domains, which means much faster convergence during spanning tree reconfiguration.
- Per-VLAN operation, which allows you to use more of the available bandwidth when you have redundant links. A particular link can be blocked on one VLAN, but still forward packets on another.

Features

There are three spanning tree models:

- Single IEEE 802.1D spanning tree
- Spanning Tree Per VLAN
- Optimized “per-VLAN” spanning trees using a scalable, two-layer spanning tree approach (The following figure compares this model with multiple levels, shown below at the right, to the single IEEE 802.1D spanning tree. See [page 4-5](#) for information on how to use multilayer spanning trees.)

All models interoperate with legacy IEEE 802.1D bridges and switches.

Comparison of Spanning Tree Models

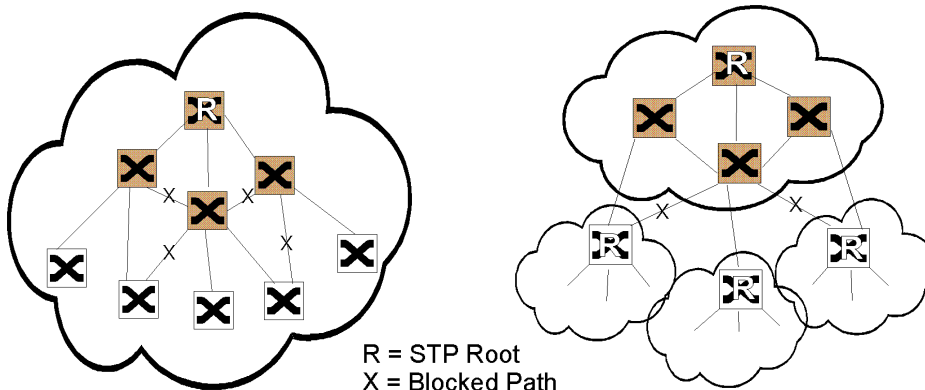

Single 802.1D Spanning Tree
One Spanning Tree
Longer convergence
One path to and from root for all VLANs
Improper configuration
can shut down Trunk Links

Multi-Level Spanning Tree
Backbone terminates 802.1D STP
Smaller STP Domains
Quicker Convergence
VLAN Load Balancing
Interoperates w/ existing Bridge/Routers

Extensive Fault Tolerance

Why It Matters

The GIGAswitch/Ethernet system is designed as a backbone switch. You can install the switch in your network's core without creating a single point of failure.

Features

- 2+1 power. Power supplies share the power supply load. If a power supply fails, the remaining supply or supplies assume the load automatically and the switch management system warns you of the failure.
- Hot-swappable power supplies, fans, and modules. Each can be changed from the switch front panel, without powering down the switch.
- Redundant switch links (using spanning tree and hunt groups).
- Front-loadable cables, modules, power supplies and fans.
- Redundant switch control processor, switch matrix, and switch controller modules (optional [not available for V1.0]).

Buffer and Queue Management

Why It Matters

Adding gigabit speeds to existing networks means that there can be a huge disparity between link speeds. For example, anything more than a 1-percent load on a gigabit link could easily overwhelm a 10 Mb/s Ethernet link.

Without queue and buffer management, gigabit links might only move congestion in a network, rather than relieving it.

Features

The switch employs the following buffer and queue management techniques:

- Configurable active backpressure
 - Half-duplex ports use active backpressure to jam input ports when their frame buffers are full.
 - Full-duplex links use IEEE 802.3x pause control frames to pause traffic when buffers are full.
- Packed frame buffers for optimal memory utilization. The GIGAswitch/Ethernet system approach to memory management allows virtually 100% utilization of buffer memory.

Features

- Two Class of Service priority queues that provide flexible queue management algorithms to meet application requirements
- Large buffer space
 - 512 KB per gigabit port
 - 128 KB additional for outbound 10/100 ports
- Configurable queue depth for each of two prioritized packet queues
- Configurable priority threshold
- Configurable service ratio tunes queue priority

Web-Based Management

Why It Matters

Web-based management allows you to manage switches from any station connected to your network.

General Features

The switch offers a command line interface to set up connection, and a rich set of web-based management features:

- **RISC-Based Switch Control Processor (SCP)** — Provides high-speed VLAN, RMON, and network management support.
- **Web Agent** — Built-in SNMP and HTML-based agent, compatible with popular Web browsers. Provides top-to-bottom switch management.

Smart Web Agent

- Built-in support for SNMP and HTML
- Out-of-band from 10BASE-T or RS-232 on the switch control processor
- Powerful alarm and event logging subsystem
- Point and click interface with Netscape Navigator V3.0, or later or Microsoft Internet Explorer V3.0 or later

RMON for Traffic Analysis

- Four groups implemented in hardware
- Configurable mirror destination per switch fabric port

Gigabit Ethernet MIB

- For use with network management SNMP agents

Chapter 3

Configuring the GIGAswitch/Ethernet System

Overview

Introduction

Read this chapter if you are powering up the DIGITAL GIGAswitch/Ethernet system for the first time. It explains:

- Initial setup and configuration of the switch using the serial console port
- Creating user accounts
- Configuring ports

In This Chapter

This chapter contains the following topics:

Topic	Page
What You Will Need	3-2
Connecting to the GIGAswitch/Ethernet System Web Agent	3-3
Configuring the Switch Using the Web Agent	3-6

What You Will Need

What You Will Need

To complete initial switch setup, you need a PC with a serial line connection. It must have the following terminal setting to communicate with the switch.

Table 3-1: Terminal Setup

Baud Rate	Stop Bits	Data Bits	Flow Control	Parity
9,600	1	8	Xon/Xoff	None

Connecting to the GIGAswitch/Ethernet System Web Agent

To connect to the web agent, you must first use the serial command line interface to give the switch control processor an IP address and a subnetwork mask. To do this:

Step	Action
1	Start the switch as instructed in Powering On the System on page 1-14 .
2	Use the out-of-band connection kit (page 1-2) to connect from the serial port on your PC to the serial port on the switch control processor (shown below): <ol style="list-style-type: none">Connect the connector marked MDCE to the switch.Connect the connector marked FDTE to the PC.Connect the straight-through RJ45 cable between the connectors.

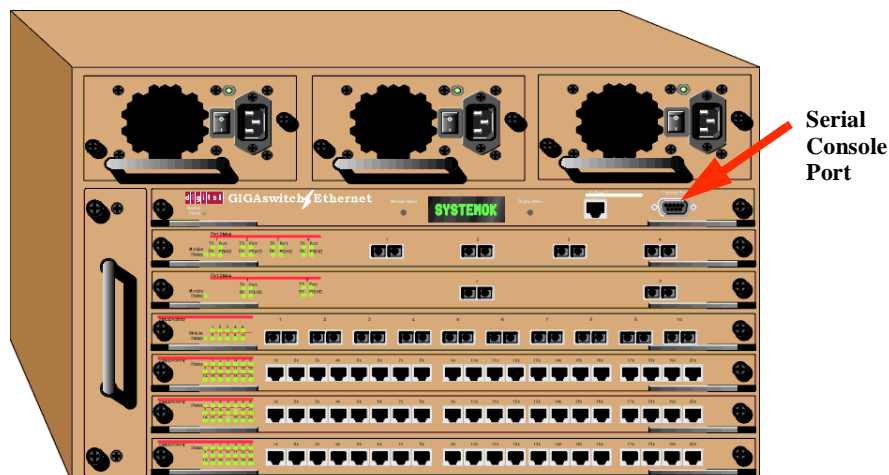

Note: To check that you have the straight-through cable, line up the cable *ends*; the wire colors inside the connectors should match exactly. (See [Table 1-2 on page 1-11](#) for pinouts.)

- 3 Run a terminal emulation program (HyperTerminal, for example) on the attached PC. Make sure that the terminal settings match those listed in [Table 3-1](#).

Connecting to the GIGAswitch/Ethernet System Web Agent

Step	Action
4	<p>Press Enter on the PC's keyboard. The following prompt displays:</p> <p>Login:</p> <p><u>Note:</u> The user name and password are case sensitive.</p>
5	<p>Enter the username "root". The terminal prompts for a password.</p> <p>Password:</p>
6	<p>Enter "root" (the default password), then press Enter. The command prompt displays.</p>
7	<p>Enter the following command:</p> <pre>GIGAswitch Ethernet> net ip address ethernet_console <ip address> <ip mask></pre> <p>Where <ip address> is the IP address of the switch and <ip mask> is the subnetwork mask. The mask must be in decimal numbers (255.255.255.0, for example).</p>
8	<p>Press Enter.</p>
9	<p>Enter a default gateway (first hop router) for the subnetwork this switch connects to using the following command:</p> <pre>GIGAswitch Ethernet> net ip default_gateway ethernet_console <address></pre> <p>Where <address> is the address of the router port.</p>
10	<p>To assign addresses to the web agent for inband access over the network, enter the following commands to give the switch control processor module's network interface an IP address and default gateway:</p> <pre>GIGAswitch Ethernet> net ip address inband <ip address> <ip mask></pre> <pre>GIGAswitch Ethernet> net ip default_gateway inband <address></pre> <p><u>Note:</u> Do not use the same IP address for both the console port and the inband connection. Each interface must have a unique IP address, and be on a separate IP subnetwork.</p>

Depending on which IP addresses you have assigned, you can connect to the system inband using the 10BASE-T port on the switch control processor module front panel.

Connecting to the GIGAswitch/Ethernet System Web Agent

To connect using the console 10BASE-T port:

Step	Action
1	Attach the 10BASE-T-compliant crossover cable (page 1-2) to the RJ45 connection in the switch front panel as shown below. (See Table 3-2 for pinouts.) The other end is assumed to be connected to an Ethernet end-station such as a PC with a web browser installed. If you are connecting the Ethernet console port to a repeater or switch port, use a straight-through 10BASE-T cable.

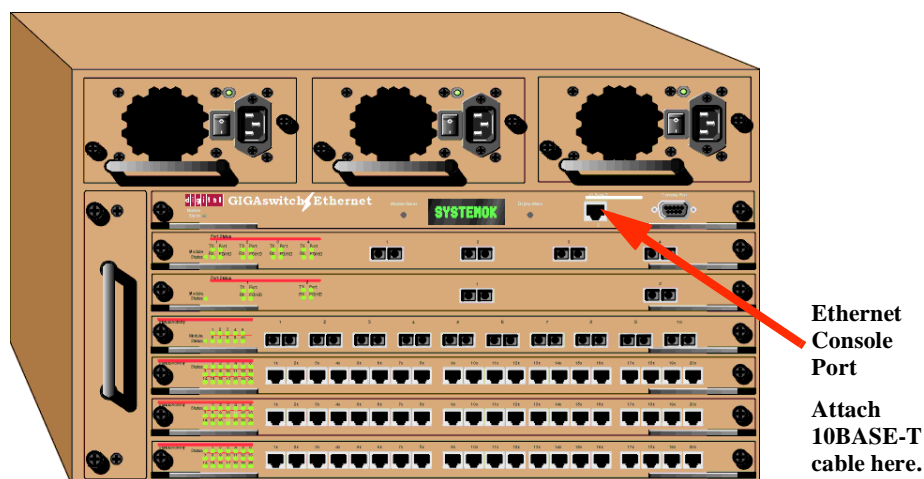

- 2 Log in to the switch using a web browser, as described in [Logging In to the Web Agent on page 3-7](#).

Table 3-2: Pinouts for 10BASE-T Crossover Patch Cables

Pin	Color	Pin	Color
1	WO	3	GW
2	O	6	G
3	WG	3	WO
4	B	4	B
5	WB	5	WB
6	G	2	O
7	WBr	7	WBr
8	Br	8	Br

Configuring the Switch Using the Web Agent

Configuring the Switch Using the Web Agent

The system provides an embedded HTTP server, the web agent, that allows you to set all parameters on a particular switch.

Web Agent Interface

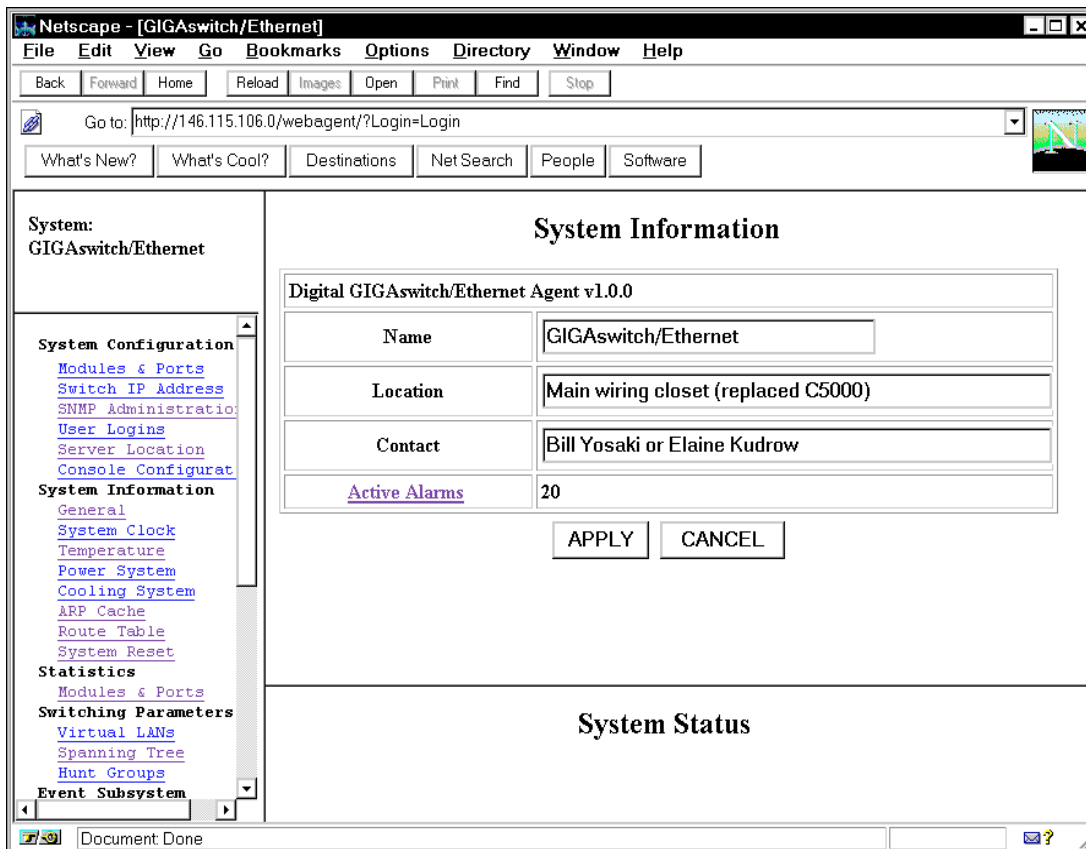

Configuring the Switch Using the Web Agent

Logging In to the Web Agent

Although the web agent supports any frames-capable browser, the system has been qualified with the following browsers:

- Netscape Navigator 3.0 or later
- Microsoft Internet Explorer 3.0 or later

To log in to the web agent:

Step	Action
1	Start your browser.
2	Enter the URL of the switch you want to manage in the Location field, using the switch's IP address (example: <code>http://146.115.106.0</code>). Remember that each interface to the switch control processor (console or inband) has a separate IP address.
3	Press Enter . The switch login screen displays.
4	Click on the Login button.
5	Enter a valid user name, then press Tab . (The default user name for administrators is root .)
6	Enter the password for the user name you entered. (The default password is root .) The web agent displays.

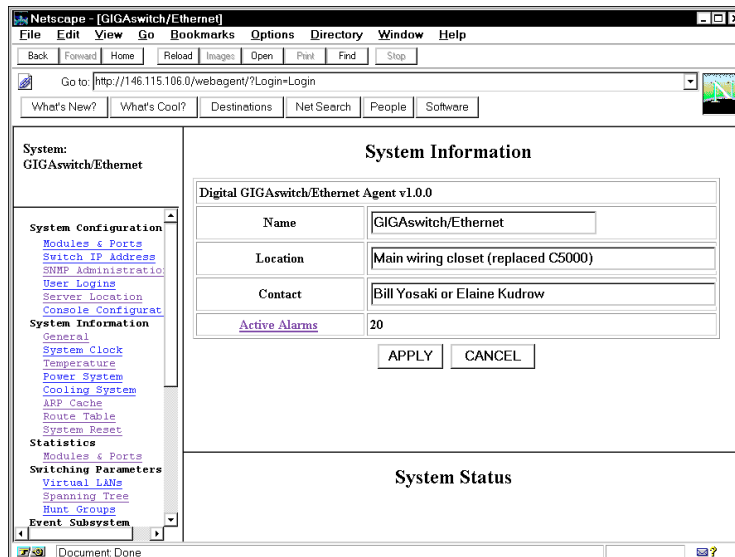

Note: Change the root password for the system as soon as possible to prevent intrusions into your system.

Configuring the Switch Using the Web Agent

Entering Basic System Information

The system lets you enter basic system identification information from the web agent. Use these fields to uniquely identify each switch. The fields are:

- Switch name
- Device location
- Device contact
- System date and time

To change these values:

Step	Action
1	Select General from the menu on the left side of the web browser display. The System Information window displays.

System Information

Digital GIGAswitch/Ethernet Agent v1.0.0	
Name	GIGAswitch/Ethernet
Location	Main wiring closet (replaced C5000)
Contact	Bill Yosaki or Elaine Kudrow
Active Alarms	20

- 2 Type a name for the switch at the **Name** prompt.
- 3 Type the location for the switch (floor and closet location, for example) at the **Location** prompt.
- 4 Type information about the person who should be contacted in the event of a problem with this switch at the **Contact** prompt.
- 5 To apply the settings, click **Apply**. **Cancel** returns the display to the current switch settings.

Configuring the Switch Using the Web Agent

-
- | Step | Action |
|------|---|
| 6 | Select System Clock from the menu on the left side of the web browser display. The System Clock window displays. |

System Clock

	Hour	Minutes	Seconds
Current Time Setting	20	39	09
	Month	Date	Year
Current Date Setting	09	24	97
<input type="button" value="APPLY"/>			

- 7 Enter the time using 24-hour time format (example: 10 p.m. is 22 00 00).
 - 8 Enter the current date.
 - 9 Press **Apply** to set the clock.
-

Configuring the Switch Using the Web Agent

Setting Up User Accounts

User accounts set up in the system allow users to access both the command line interface and the web agent. There are three default user logins available:

User Account Management		
User Name	User Access	
<input type="checkbox"/>	root	ADMINISTRATOR
<input type="checkbox"/>	diag	DIAGNOSTICS
<input type="checkbox"/>	manuf	MANUFACTURING
Add	Delete	Change Password

Table 3-3: Default User Logins

User Name	Purpose
root	Can view and set all switch parameters.
diag	Can access low-level diagnostics functions from the command line interface. This feature is not documented and should be used only with the assistance of qualified service personnel.
manuf	Can access manufacturing functions from the command line interface. This feature is not documented and should be used only with the assistance of qualified service personnel.

To add a user to this interface:

Step	Action
1	Log in to the switch from your web browser, using a user name with administrator privileges. (The default login of user root , password root has this authority.) The web agent main screen displays.
2	From the menu bar on the left side of the browser window, select User Logins . The User Account Management screen displays.

Configuring the Switch Using the Web Agent

Step	Action
3	Click on Add . The Add User Account screen displays.

Add User Account

User Name:	Bill
Password	*****
Access Type:	<div style="display: inline-block; border: 1px solid gray; padding: 2px;"> READ_WRITE ▼ </div>
<input type="button" value="APPLY"/>	<input type="button" value="CANCEL"/>

- 4** Type in a user name for the account, then press **Tab**.
- 5** Type in a password for the account, then press **Tab**.
Note: Use caution entering the password as you will not be prompted for a confirmation.
- 6** Use the drop-down menu to select an access type. The types are as follows:

Table 3-4: User Account Access Levels

User Level	Can	Cannot
User (READ_ONLY)	View switch configuration settings and statistics.	View user accounts and community strings. Change switch configurations.
Manager (READ_WRITE)	View <i>and set</i> switch configuration settings, and view statistics.	View user accounts and community strings.
Administrator (ADMINISTRATOR)	View and set all switch parameters.	N/A

- 7** To apply the settings, click **Apply**. **Cancel** returns the current switch settings.

Configuring the Switch Using the Web Agent

Configuring Port Parameters Using the Web Agent

The system has two levels of port settings:

- Physical port parameters, which allow you to set up rules that guide the system's physical layer interaction (enable/disable, speed, auto-negotiation, for example)
- Switch port parameters, which allow you to set how the port participates in switching (VLAN mode, trunking, for example)

Configuring Physical Port Parameters on Gigabit Ports

You can set the following attributes on gigabit ports:

Table 3-5: Gigabit Port Settable Attributes

Attribute	Purpose
Enable/Disable	Determines whether or not the port is able to pass traffic.
Port Name	A user-assigned name for this port (possibly a drop name or the name of the station or other device connected to the port).
Flow Control Mode	Determines if IEEE 802.3x pause control is used on this port. The pause mechanism allows the port to stop a sending station from sending more packets if the receiving port's buffers are full. This helps prevent lost or dropped packets.

Configuring the Switch Using the Web Agent

To configure ports on a gigabit module:

- | Step | Action |
|------|---|
| 1 | From the menu on the left side of the browser window, select Modules & Ports . A list of modules in the switch displays. |

Module Information						
Slot	Model Number	Type	Ports	Switch Ports	Buffer Management	Name
<input type="checkbox"/> 1	DGBGL-AA	Switch Control Processor	1	1	Module 1	Module 1
<input type="checkbox"/> 2	DGBGL-AA	Gigabit	2	2	Module 2	Module 2
<input type="checkbox"/> 3	DGBGT-AA	Fast Ethernet	20	20	Module 3	Module 3
<input type="checkbox"/> 5	DGBGL-AA	Gigabit	2	2	Module 5	Module 5
<input type="checkbox"/> 6	DGBGT-AA	Fast Ethernet	20	20	Module 6	Module 6

- 2 On the module you want to configure, click on the number of ports listed in the ports column (2 or 4 for gigabit modules). The Port Information form displays.

Port Configuration - Module 2								
Port	Name	Enable	Status	Type	Connector	Auto Negotiation Mode	Speed State	Duplex State
2.1	Port 2.1	<input checked="" type="checkbox"/>	Link Failure	Gigabit	Fiber SC	Disabled	1 Gb/s	Full Duplex
2.2	Port 2.2	<input checked="" type="checkbox"/>	Link Failure	Gigabit	Fiber SC	Disabled	1 Gb/s	Full Duplex

[Next Module](#)
[Modules](#)
[All Module Ports Configuration](#)

Configuring the Switch Using the Web Agent

Step	Action				
3	To enable or disable a port: <ol style="list-style-type: none">Click the box in the Enable column to enable a port, or click to uncheck Enable if you want to disable the port.Click Apply to perform the operation. Cancel returns the display to the current switch settings.				
4	To set additional parameters, click on the port name in the Name column. The Detailed Port Configuration window displays. <div data-bbox="430 865 1138 1222" data-label="Form"><p>Detailed Port Configuration - Module 5 Port 1</p><table border="1"><tr><td>Name</td><td>Port 5.1</td></tr><tr><td>Flow Control Mode</td><td>Disable</td></tr></table><p><input type="button" value="APPLY"/> <input type="button" value="CANCEL"/> Next Port Module</p></div>	Name	Port 5.1	Flow Control Mode	Disable
Name	Port 5.1				
Flow Control Mode	Disable				
5	Set the port name by typing a port name in the Name field.				
6	If you want this port to use flow control to prevent buffer overflows, set Flow Control Mode to enable using the drop-down list. Disable this feature only when flow control is causing congestion in other areas of the network.				
7	To apply the settings to the port, click Apply . Cancel returns the display to the current switch settings.				

Configuring the Switch Using the Web Agent

Configuring Physical Port Parameters on Fast Ethernet Ports

You can set the following attributes on Fast Ethernet ports:

Table 3-6: 10/100 Port Settable Attributes

Attribute	Purpose
Enable/Disable	Determines whether the port is able to forward traffic.
Port Name	A user-assigned name for this port (possibly a drop name or the name of the station or other device connected to the port).
Speed Mode (10/100 ports)	Lets you select the speed of the port manually (to either 10 or 100 Mb/s). If auto-negotiation is enabled, this setting is ignored.
Port Duplex Mode (10/100 ports)	Lets you set the port duplex mode (half- or full-duplex). If auto-negotiation is enabled, this setting is ignored.
Flow Control Mode	<p>If the port is set to half-duplex mode, this setting determines whether active backpressure is used on this port. Active backpressure jams the sending Ethernet channel until the port's buffers can receive more packets.</p> <p>If the port is set to full-duplex mode, this setting determines whether IEEE 802.3x pause control is used on this port. The pause mechanism allows the port to stop a sending station from sending more packets if the receiving port's buffers are full.</p> <p>Enabling flow control helps prevent lost or dropped packets.</p>
Auto-negotiation Mode	Allows you to set the port to auto-negotiate a speed and duplex mode. Auto-negotiation works best when the connection on the other end of the link is set to auto-negotiate as well. If you set a port to auto-negotiate, and the connection is not successful, set the port speed and duplex mode manually.
Auto-negotiating Speed/Duplexity Advertisement	Determines what information the port advertises when it starts auto-negotiating. In most cases, 10/100 and Half/Full are the best settings, but there may be cases when you want to auto-negotiate one parameter, while keeping the other fixed.

Configuring the Switch Using the Web Agent

Table 3-6: 10/100 Port Settable Attributes

Attribute	Purpose
Rate Limit Mode	This feature helps prevent the switch from overwhelming the output buffer on lower-speed ports by placing a threshold on the percentage of port traffic that can be flooded packets (unknown broadcasts, unicasts and multicasts). You can optionally include known multicast packets in this percentage to further decrease the possibility of the port's output buffer being overwhelmed.

To configure ports on a Fast Ethernet module:

Step	Action
1	From the menu on the left side of the browser window, select Modules & Ports . A list of modules in the switch displays.
2	On the module you are configuring, click the number of ports listed in the ports column (10 for 100BASE-FX, for example). The Port Configuration form displays.

Port	Name	Enable	Status	Type	Connector	Auto Negotiation Mode	Speed State	Duplex State
5.1	Port 5.1	<input checked="" type="checkbox"/>	Okay	10/100 Tx	RJ45	Enabled	100 Mb/s	Full Duplex
5.2	Port 5.2	<input checked="" type="checkbox"/>	Okay	10/100 Tx	RJ45	Enabled	10 Mb/s	Half Duplex
5.3	Port 5.3	<input checked="" type="checkbox"/>	Link Failure	10/100 Tx	RJ45	Enabled	Auto-Negotiating	Auto-Negotiating
5.4	Port 5.4	<input checked="" type="checkbox"/>	Link Failure	10/100 Tx	RJ45	Enabled	Auto-Negotiating	Auto-Negotiating
5.5	Port 5.5	<input checked="" type="checkbox"/>	Link Failure	10/100 Tx	RJ45	Enabled	Auto-Negotiating	Auto-Negotiating

- 3 To enable or disable a port:
- Click to the box in the Enable column to enable a port, or click to uncheck Enable if you want to disable the port.
 - Click **Apply** to perform the operation. **Restore** returns the display to the current switch settings.

Configuring the Switch Using the Web Agent

Step	Action
4	To set additional parameters, click on the port name in the Name column. The Detailed Port Configuration window displays.

Detailed Port Configuration - Module 6 Port 1

Name	<input type="text" value="Port 6.1"/>
Speed Mode	<input type="text" value="100 Mbps"/> ▾
Duplex Mode	<input type="text" value="Full Duplex"/> ▾
Flow Control Mode	<input type="text" value="Disable"/> ▾
Auto Negotiation Mode	<input type="text" value="Enable"/> ▾
Auto Negotiation Speed Advertisement	<input type="text" value="10/100 Mbps"/> ▾
Auto Negotiation Duplex Advertisement	<input type="text" value="Full/Half Duplex"/> ▾
Rate Limit Mode	<input type="text" value="Disable"/> ▾
Rate Limit Rate	<input type="text" value="20%"/> ▾
Rate Limit Burst Size	<input type="text" value="256"/> ▾

[Next Port](#) [Module](#)

- 5 Set the port name by typing a port name in the **Name** field.
- 6 If you want to set the port speed manually, select a speed (**10 Mb/s** or **100 Mb/s**) from the drop-down list. If you set the port to auto-negotiate, this setting is ignored.
- 7 If you want to set the port's duplex mode manually, select a mode (**Half-duplex** or **Full-duplex**) from the drop-down list. If you set the port to auto-negotiate, this setting is ignored.
- 8 If you want this port to use Flow Control to prevent buffer overflows, set Flow Control Mode to **enable** using the drop-down list. Disable this feature only when flow control is causing congestion in other areas of the network.

Configuring the Switch Using the Web Agent

Step	Action
9	<p>Set the Auto-negotiate Mode for the port (enable or disable) from the drop-down list.</p> <p><u>Note:</u> This feature works best when the port or device on the other end of the connection auto-negotiates as well. If you are having problems with auto-negotiating connections, try setting the modes manually.</p>
10	<p>Set an Auto-negotiating Speed and Auto-negotiating Duplex Advertisement using the drop-down lists. The switch sends these values to the device on the other end of the connection at the start of the auto-negotiating process. In general, the defaults are best, but there may be situations when you want to fix one setting, but allow the other setting to auto-negotiate.</p>
11	<p>If you want this port to limit the number of unknown unicast and multicast (flooded) packets it tries to forward, set the Rate Limit Mode to enable, then:</p> <ul style="list-style-type: none">a) Select the percentage of a port's traffic that can be unknown unicast and broadcast packets. Enter this value in the Rate Limit Rate field. Lower this value if the port is having overflow problems.b) Set a Rate Limit Burst size to limit the number of packets allowed in a single burst. Legal values are 1 to 2048. For Fast Ethernet ports, set this value lower than 1024 (the output buffer's capacity). Set this value lower if the port is experiencing overflow problems.
12	<p>To apply the settings to the port, click Apply. Restore returns the display to the current switch settings.</p>

Using the All Module Ports Configuration Screen

The All Module Ports Configuration screen lets you apply the same parameter settings to all ports in a module using a single command. To do this:

Step	Action
1	Select All Module Ports Configuration from the Port Configuration screen.
2	Set port parameters as described beginning on page 3-12 .
3	Click Apply to apply the changes to all ports on the module.

Configuring the Switch Using the Web Agent

Configuring Switch Port Parameters

Switch port parameters set how each port performs switching functions (for example, VLAN parameters and hunt group assignments). To configure switch port parameters using the web agent:

- | Step | Action |
|------|---|
| 1 | From the menu on the left side of the browser window, select Modules & Ports . A list of modules in the switch displays. |

Module Information						
Slot	Model Number	Type	Ports	Switch Ports	Buffer Management	Name
<input type="checkbox"/> 1	DGBGL-AA	Switch Control Processor	1	1	Module 1	Module 1
<input type="checkbox"/> 2	DGBGL-AA	Gigabit	2	2	Module 2	Module 2
<input type="checkbox"/> 3	DGBGT-AA	Fast Ethernet	20	20	Module 3	Module 3
<input type="checkbox"/> 5	DGBGL-AA	Gigabit	2	2	Module 5	Module 5
<input type="checkbox"/> 6	DGBGT-AA	Fast Ethernet	20	20	Module 6	Module 6

- 2 From the module menu, select the module you want to configure ports on, then double-click on **Switch Ports** in the Switch Ports column next to the selected module. The Switch Ports menu displays.

Switch Ports							
Module Number 5							
Links	Port	Port VLAN	VLAN Classification	Trunk Mode	Hunt Group	STAP Mode	MAC Address
No links available	Port 5.1	Default	Port Based	Clear	[None]	Enable	02-e0-3b-00-08-01
Port Statistics	Port 5.2	Default	Port Based	Clear	[None]	Enable	02-e0-3b-00-08-02
Port Statistics	Port 5.3	Default	Port Based	Clear	[None]	Enable	02-e0-3b-00-08-03
Port Statistics	Port 5.4	Default	Port Based	Clear	[None]	Enable	02-e0-3b-00-08-04

Configuring the Switch Using the Web Agent

Step	Action
3	Click Ports in the column next to the port you want to configure parameters for. The Switch Port Configuration Form for the selected port displays.

Switch Port Configuration 6.1 : Port 6.1

Port VLAN	Default ▾
Trunk Mode	Clear ▾
Frame Tags	Use ▾
VLAN Binding	Static ▾
Automatic VLAN Creation	Disable ▾
Allow Learning	Enable ▾
Hunt Group	[None] ▾
Spanning Tree Mode	Enable ▾
Known Mode	Disable ▾
Mirror Port	Disable

- 4 If desired, select a VLAN assignment for this port by clicking in the Port VLAN pulldown menu.
- 5 If this is a VLAN trunk port (that is, it connects to another port configured as a trunk port) or an end station that supports VLAN tagging, and you want packets exiting this port to have a VLAN tag applied, use the Trunk Mode pulldown menu to select a format. Use this feature when the device on the other end of the connection uses a VLAN tagging scheme. The options are described in [Table 3-7](#). Refer to [Using Virtual LANs on page 4-2](#) for more information on VLAN creation and setup.

Table 3-7: VLAN Trunking Modes

VLAN Mode	Applies this format to packets leaving this port:
Clear	Applies no VLAN tag.
IEEE-802.1Q	Applies the IEEE 802.1Q Ethernet VLAN tagging scheme.

Configuring the Switch Using the Web Agent

Step	Action
6	Select whether you want to ignore or use received Frame VLAN tags. Refer to Table 3-8 for setting descriptions.

Table 3-8: Use of Incoming Frame VLAN Tags

Frame Tags Setting	Applies the following format to packets leaving this port:
Use	The switch uses the information in the VLAN tag to determine a packet's VLAN destination.
Ignore	The switch ignores VLAN tags on incoming packets and uses its own VLAN settings to determine a packet's VLAN destination.

- 7 Select a VLAN binding type for this port. The options are described in [Table 3-9](#).

Table 3-9: VLAN Binding Options

Option	Definition
Static	Assign VLAN membership manually.
Persistent	Bind this to port all VLANs known to the switch. This is an appropriate mode for switch-to-switch connections.
Dynamic	Bind this port to any VLAN it receives traffic from. Note: If Automatic VLAN Creation is enabled, the port will bind to previously unknown VLANs, and a VLAN entry will be added to the switch VLAN table. If Automatic VLAN Creation is disabled, the port will not bind to any VLAN already known to the switch.

Configuring the Switch Using the Web Agent

Step	Action
8	If you want this port to automatically add an entry to the switch VLAN table each time it receives a packet from an unknown VLAN, set Automatic VLAN Creation to enable .
9	If you want a particular port to stop learning new addresses, set Allow Learning to disable .
10	If you want this port to be a member of a particular hunt group, select a group from the drop-down list.
11	If you want to enable or disable spanning tree protocol on this port, use the drop-down list to make the appropriate selection.
12	If you do not want packets with unknown unicast destination addresses flooded to this port, set Known Mode to enable . For example, if a known end station or file server is connected to the port, there's no need to flood unknown unicasts to that port.
13	To apply the changes: <ul style="list-style-type: none">a) Click on the port number in the port column. This confirms that you want to perform an action on this port, and allows you to apply operations on several ports at once if you choose.b) Click Apply to perform the operation. Cancel returns the display to the current switch settings.

Using the All Module Ports Configuration Screen

The All Module Ports Configuration screen lets you apply the same parameter settings to all switch ports in a module using a single command. To do this:

Step	Action
1	Select All Module Ports Configuration from the Switch Port Configuration screen.
2	Set port parameters as described beginning in Configuring Switch Port Parameters on page 3-19 .
3	Click Apply to apply the changes to all ports on the module.

Setting Up SNMP Communities

To manage the switch using an SNMP manager, you must set certain SNMP values on the switch. To do this:

Step	Action
1	From the web agent interface, select SNMP Administration from the left side of the browser window. The SNMP Community Management screen displays.

Community String	IP Address	Access	Security Level	Trap Receiver
<input type="checkbox"/> public	***.***.***.***	Read/Write	Normal	Disable

CREATE DELETE

- 2 Click **Create**. The Create SNMP Community screen displays.

Community String	<input type="text"/>
IP Address	Any <input type="text"/> <input type="text"/> <input type="text"/> <input type="text"/>
Access	Read-Write <input type="text"/>
Security Level	Normal <input type="text"/>
Trap Receiver	Enable <input type="text"/>

APPLY CANCEL

- 3 Enter a community name at the Community String prompt. This string serves as a password that you enter at the network management station. It provides the level of access to the switch that you specify on this page.
- 4 Enter an IP Address at the IP Address prompt if you want the switch to send SNMP responses only to a station with a particular IP address. This helps provide security when you use SNMP to manage the network from a single workstation.

Configuring the Switch Using the Web Agent

Step	Action
5	Select an access level for this community. The options are described in the following table:

Access Level	Manager Can	Manager Cannot
readonly	View switch configuration settings and statistics.	View community strings. Change switch configurations.
readwrite	View <i>and set</i> switch configuration settings, and view statistics.	View community strings.
readwrite with Security Level set to admin	View and set all switch parameters, including community table.	
morespecific	N/A. Feature not used in this release.	N/A
disable	Do nothing. This selection allows you to disable a string without deleting it.	Access any switch features.

- 6 Set a security level for this community string. The options are described in [Table 3-10](#).

Table 3-10: SNMP Security Levels

Option	Allows
normal	Access to all switch configuration and reporting functions.
admin	Access to all switch configuration and reporting functions, plus access to community configuration .

- 7 Select whether you want to send traps to members of this community. Selecting **enable** causes system traps to be sent to the selected IP address.
- 8 Click **Apply** to create the community string.

Changing the Console Serial Port Settings

You can use the web agent to change the communications settings for the serial port connection on the front panel of the switch control processor. To do this:

Step	Action
1	Select Console Configuration from the menu on the left side of the web agent browser window. The Console Port Configuration screen displays.

Console Port Configuration

Console Type	TTY
Baud Rate	9600 ▾
Flow Control	Xon/Xoff ▾
Data Bits	8 ▾
Parity	None ▾
Stop Bits	1 ▾

- 2 Choose from the available settings. Options are described in [Table 3-11](#).

Table 3-11: Terminal Setting Options

Option	Default	Available Settings
Baud Rate	9600	300, 1200, 2400, 4800, 9600, 19200, 38400, 115200
Flow Control	Xon/Xoff	None, Hardware, Xon/Xoff
Data Bits	8	7 or 8
Parity	None	Odd, Even, or None
Stop Bits	1	1 or 2

- 3 Click **Apply** to save your settings.

Configuring the Switch Using the Web Agent

Setting Up the Information Server

The DIGITAL GIGAswitch/Ethernet System Information Library CD provides resources used by the web agent. These resources are located off the switch on a web server to preserve switch memory. Although they are not essential to the operation of the web agent, these resources provide you with:

- Online help for the web agent
- Bitmaps used as part of the web agent's interface display (logo, wallpaper)
- Online documentation

Setting up a server location for the switch allows the switch to access this information. The illustration below provides a snapshot of how the communication works:

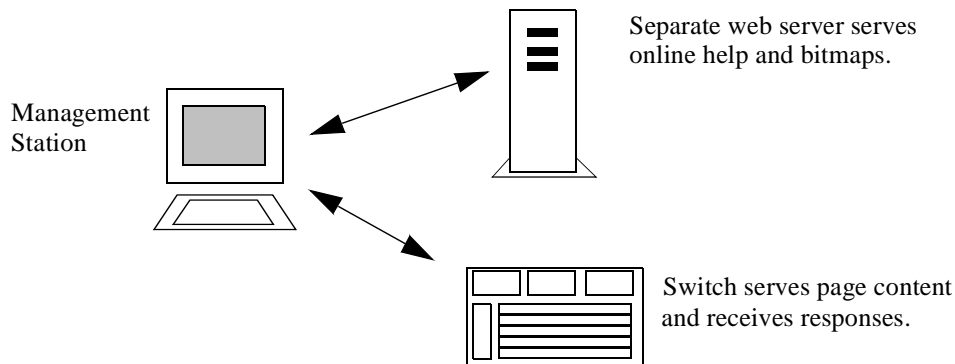

The library's Setup program provides you with options for serving this information to the switch. You can:

- Add the Information Library to an existing server on your network.
- Install the Information Library and its HTTP server software. The machine on which you install the library's server software must be running either Windows 95 or Windows NT.

To set up the Information Library:

Step	Action
1	Run Setup.exe .
2	Follow the instructions presented on the screen to install the library with the options you prefer.

Configuring the Switch Using the Web Agent

Step	Action
3	Enter the server location in the switch using the web agent interface as described in Setting the Server Location below.

The Information Library is also available from the DIGITAL Network Products Home Page on the World Wide Web. See [page xiv](#) for access information.

Setting the Server Location

To set the location of the Information Library server in the switch:

Step	Action
1	From the menu on the left side of the web browser display, select Server Location .
2	Enter the host name or IP address of the HTTP server at the Http Server Location prompt. If you are using the Information Library server supplied by DIGITAL, follow the server name with “:2010”. For example, for a host named “phantom,” enter: http://phantom:2010
3	Enter help at the Help Directory Location prompt.
4	Click Apply .

NOTE

Web agent performance may slow down if the Information Library server becomes unavailable. If this occurs, click the **Stop** button on the browser (this stops the switch from searching for the server), then delete the Server Location description until the server becomes available again.

Chapter 4

Tuning Your Network Using VLANs, Spanning Tree, and Hunt Groups

Overview

Introduction

This chapter describes how to use the DIGITAL GIGAswitch/Ethernet system's advanced features to optimize bandwidth usage on your network.

In This Chapter

This chapter contains the following topics:

Topic	Page
Using Virtual LANs	4-2
Using Spanning Tree Setup and Monitoring	4-5
Using Hunt Groups to Aggregate Bandwidth Between Switches	4-13

Using Virtual LANs

Why Use VLANs?

In the world of switched networks, VLANs help you to segment traffic and usage patterns in a manner similar to creating network subnets and segments in a traditional shared LAN environment. Use VLANs to:

- Segment your network into manageable broadcast domains, which increases available bandwidth for each station
- Create logical workgroups for users who share the same system resources (file servers, printers, etc.)

VLANs also have the advantage of not being limited by physical switch domains. Users in various physical locations can participate in the same VLAN.

Finally, in a GIGAswitch/Ethernet system network, you can use VLANs to limit spanning tree domains, so that the network converges more quickly during spanning tree reconfiguration.

Creating and Implementing VLANs using the Web Agent

Adding users to VLANs using the web agent is a two-step process:

- 1) [Creating a VLAN](#)
- 2) [Assigning Ports to VLANs](#)

Creating a VLAN

To create a VLAN:

Step	Action
1	Select Virtual LANs from the menu on the left side of the browser window. The VLAN Configuration window displays.

VLAN Configuration

	Name	ID	Group ID	AFT Index
<input type="checkbox"/>	Default	1	2	1
<input type="checkbox"/>	Discard	4097	3	3
<input type="checkbox"/>	Engineering	2	4	7

CREATE
MODIFY
DELETE

- 2 Click **Create**. The Create VLAN screen displays.

Create VLAN

Name:	
ID:	
Initial Hash Table Size:	1024 ▾
Auto-Increment HT Size:	TRUE ▾

APPLY
CANCEL

- 3 Enter a name for the VLAN at the **Name** prompt.
- 4 Enter an unused VLAN ID (between 1 and 4096) at the **ID** prompt.
- 5 Use the [Table 4-1](#) to configure the additional parameters.
- 6 Click **Apply** to create the new VLAN.

Using Virtual LANs

Table 4-1: Create VLAN Parameters

Parameter	Definition
Name	Name string assigned to this VLAN.
ID	Identifier used throughout the network to identify this VLAN. If you want ports on more than one device to participate in a particular VLAN, you must use the same VLAN ID to identify the VLAN on every device.
Initial Hash Table Size	Sets the number of memory “buckets” used to store information for this VLAN. Use the default value unless instructed to do otherwise by a qualified DIGITAL service representative.
Auto Increment HT Size	Determines whether the number of memory “buckets” used by this VLAN’s address table adjusts automatically when memory use become inefficient. Use the default value unless instructed to do otherwise by a qualified DIGITAL service representative.

Assigning Ports to VLANs

Refer to [Configuring Switch Port Parameters on page 3-19](#) for instructions on assigning ports to VLANs.

Using Spanning Tree Setup and Monitoring

Why Use Spanning Trees?

Use spanning trees to prevent loops from forming in your network. The spanning tree algorithm creates a single path through the network by making sure that if more than one path exists between two parts of a network, only one of these paths is used, while the others are blocked.

NOTE

You should have a good understanding of spanning tree protocol before attempting to configure these parameters.

Because of the number of “bridges” present in a switched networking environment, spanning tree structures can become extremely complex. The GIGAswitch/Ethernet system adds an extra layer of functionality with the introduction of multilayer spanning trees.

To better understand how spanning tree works, we need to set up a good conceptual model of how spanning trees work in the GIGAswitch/Ethernet system.

What Is a “Bridge” in a GIGAswitch/Ethernet System Spanning Tree?

- **If you use the default 802.1D Spanning Tree option**, the entire switch is a bridge, for which spanning tree parameters can be set. Every port, regardless of VLAN membership, is part of the same spanning tree. The implication is that after resolving the spanning tree topology, only one trunk will be active between any two switches.
- **If you use the Spanning Tree per VLAN option**, each VLAN runs a separate spanning tree with its own Bridge Protocol Data Units (BPDUs). This allows different ports to be blocked or unblocked on different VLANs
- **If you use the Multilayer Spanning Tree option**, within a set of interconnected GIGAswitch/Ethernet system switches, you can set up a separate spanning tree for each VLAN. The advantage with this option is that the GIGAswitch/Ethernet system network terminates any existing 802.1D spanning tree, creating smaller spanning tree domains and providing quicker convergence upon reconfiguration. This is because 802.1D BPDUs are discarded when received by the switch in this mode.

Using Spanning Tree Setup and Monitoring

What Are the Implications of a Multilayer Spanning Tree?

The easiest way to look at it is to look at each VLAN as a separate bridge (or Virtual Bridge, if you prefer).

Because each VLAN is a separate bridge, you can set the entire range of bridge and bridge port spanning tree commands for that bridge. This lets you pass traffic over links that would otherwise be blocked.

Example:

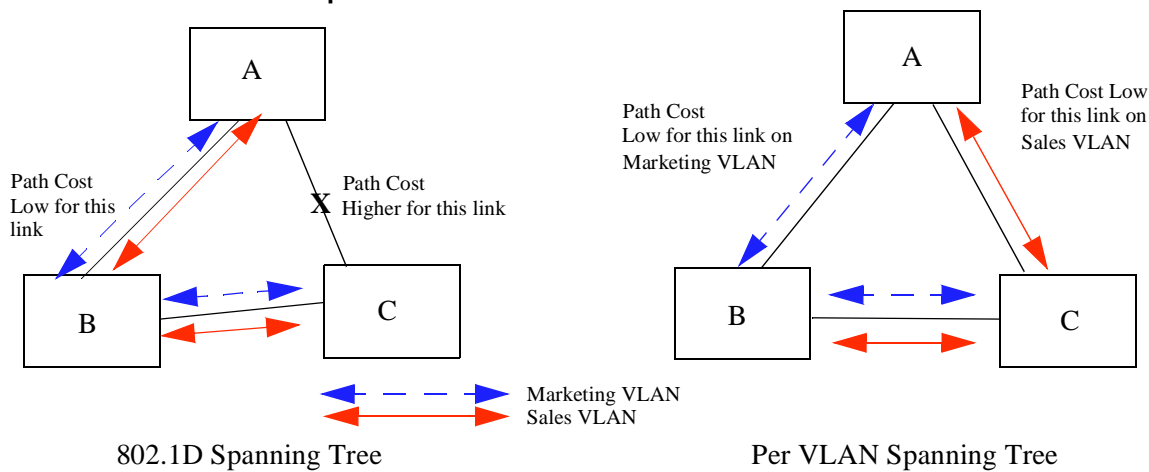

Multilayer spanning trees are also isolated from the main legacy spanning tree, and are therefore smaller and converge faster. This is a huge advantage in a large switched network, where a spanning tree reconfiguration could literally bring down the network for hours.

Managing Spanning Trees Using the Web Agent

To manage GIGAswitch/Ethernet system spanning trees from the web agent:

Step	Action
1	Click Spanning Tree from the menu on the left side of the browser window. The Spanning Tree Information window displays.

Spanning Tree Information

Configuration Dual-Layer ▾

APPLY CANCEL

Bridge Information

Bridge	Status	Bridge ID	Bridge Ports	Designated Root	Root Port	Root Cost	Top. Changes	Time Since Top. Change (hh:mm:ss)
Default	Enable	0x800002E03B000D3D	15	0x800002E03B000D3D	-	0	1	00:01:44
Marketing	Enable	0x800002E03B000D3D	2	0x800002E03B000D3D	-	0	0	00:01:45
Engineering	Enable	0x800002E03B000D3D	3	0x800002E03B000D3D	-	0	0	00:01:33

- 2 Select the type of spanning tree you want to implement from the drop-down list. The options are listed in [Table 4-2](#).

Table 4-2: Spanning Tree Types

Selection	Spanning Tree Type
IEEE 802.1D	Entire switch is a single 802.1D-compliant bridge.
Per VLAN	Each VLAN functions as a separate 802.1D-compliant bridge.
Dual Layer	Spanning tree terminates at edge of GIGAswitch/Ethernet System network. Spanning Tree per VLAN within GIGAswitch/Ethernet System network.
Disable	Spanning tree not used.

- 3 Click **Apply** to confirm your selection.

Using Spanning Tree Setup and Monitoring

Step	Action
4	Click on a bridge name to set bridge parameters for that bridge. The bridge configuration window displays.

Spanning Tree Bridge Configuration

Bridge Marketing (times in seconds)

Mode	Priority	Bridge Max Age	Bridge Hello Time	Bridge Forward Delay	Max Age	Hello Time	Forward Delay
Enable ▾	32768	20	2	15	20	2	15

5 Use the table below to select bridge-level parameters:

Field Prompt	Information Type
Mode	Determines whether spanning tree is enabled or disabled for this bridge.
Priority	STP Priority level for this bridge
Bridge Max Age	Sets the maximum amount of time that this bridge retains bridging information before discarding. When the maximum age expires, the bridge assumes it has lost connection to the network, and sends out requests to be re-added to the spanning tree.
Bridge Hello Time	Time between generation of BPDUs by the root bridge.
Bridge Forward Delay	Amount of delay used when a port transitions to the forwarding state. Set by the root bridge for the segment.
Max Age	Current maximum age for this spanning tree. Determined by the root bridge.
Hello Time	Current hello time for this spanning tree. Determined by the root bridge.
Forward Delay	Current forwarding delay for this spanning tree. Set by the root bridge.

6 Click **Apply** to commit the changes.

Configuring All Ports on a Module for Spanning Tree Fast Start Mode

Fast Start mode causes ports to begin forwarding traffic without waiting for the spanning tree negotiation to complete. Examples of situations where you may want to set a port to Fast Start mode are:

- End station ports, which do not need to participate in the full spanning tree negotiation.
- Loop-free topologies, which do not need spanning tree protocol to resolve redundant connections

You can set this mode on each port individually as described in the table on page 4-12.

To set all ports in a particular module that are associated with a selected bridge to Fast Start mode:

Step	Action
1	Select Spanning Tree from the menu on the left side of the web agent browser. The first Spanning Tree Information screen displays.
2	Click on the number of ports listed in the Bridge Ports column. The first Spanning Tree Bridge Port Information screen displays.

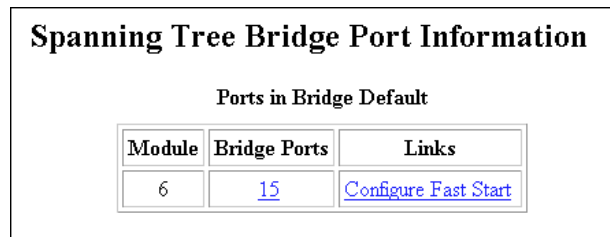

- 3 Click the **Configure Fast Start** link. The Module Fast Start Configuration window displays.

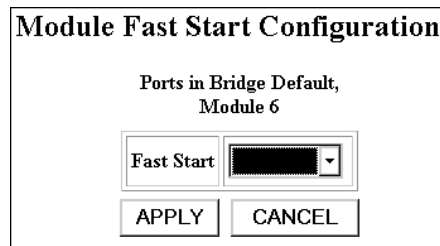

Using Spanning Tree Setup and Monitoring

Step	Action
4	Select Enable from the drop-down menu to enable Fast Start mode on the selected module ports.
5	Click Apply to confirm the change.

Configuring Spanning Tree Bridge Ports

To configure spanning tree bridge ports:

Step	Action
1	Click on the number of ports listed in the Bridge Ports column. The first Spanning Tree Bridge Port Information screen displays.

Spanning Tree Bridge Port Information		
Ports in Bridge Default		
Module	Bridge Ports	Links
6	15	Configure Fast Start

- 2 Click on the number of ports listed in the Bridge Ports column. The second Spanning Tree Bridge Port Information screen displays.

Spanning Tree Bridge Port Information									
Ports in Bridge Default, Module 3									
Bridge Port	Port	Name	State	Designated Root	Designated Bridge	Des. Port	Des. Cost	Fwd. Trans.	
58	3.1	Port 3.1	Down	-	-	-	-	0	
59	3.2	Port 3.2	Down	-	-	-	-	0	
60	3.3	Port 3.3	Down	-	-	-	-	0	
61	3.4	Port 3.4	Fwding	0x7FFF02E03B000CDA	0x800002E03B000D3D	0x803D	104	2	
62	3.5	Port 3.5	Down	-	-	-	-	0	
63	3.6	Port 3.6	Down	-	-	-	-	0	
64	3.7	Port 3.7	Down	-	-	-	-	0	

The parameters in the list are defined in the following table.

Using Spanning Tree Setup and Monitoring

State	<p>Current bridging state of the port. The options are:</p> <p>Disabled: The port is disabled.</p> <p>Blocking: The Spanning Tree algorithm has set this port's state to block, meaning that it is enabled, but not passing traffic.</p> <p>Listening: The port is in a transitional state, waiting for the spanning tree algorithm to determine whether it should block or forward traffic.</p> <p>Learning: The port is learning MAC addresses, but not yet forwarding traffic.</p> <p>Forwarding: This port has been selected by the Spanning Tree algorithm to forward traffic, and is forwarding traffic currently.</p> <p>Down: The port's associated switch port is blocked, making it impossible for this port to forward traffic.</p>
Designated Root	Displays the Root bridge for this spanning tree.
Designated Cost	The path cost of the designated root of the segment connected to this port.
Designated Bridge	The bridge identifier for the bridge considered to be the designated bridge for this segment.
Designated Port	The port identifier of the port on the designated bridge for this segment of the spanning tree.
Forward Transitions	Number of times that this port has transitioned from blocking to forwarding.

Using Spanning Tree Setup and Monitoring

Step	Action
3	Click on the bridge port number to configure bridge port parameters. The Spanning Tree Port Configuration window displays.

Spanning Tree Port Configuration

Bridge Default, Bridge Port 176 (port 6.5)

Enable	Priority	Path Cost	Fast Start
Enable ▾	128	100	Disable ▾

- 4 Use the following table to configure Spanning Tree Port Parameters:

Field Prompt	Definition
Port Number	Number of the port in the switch.
Enable	Sets whether or not Spanning Tree is active on this port.
Priority	Sets the port's priority in the spanning tree algorithm. A port with a higher priority is more likely to be chosen as the primary path in the spanning tree.
Path Cost	Sets the spanning tree path cost for this port. The ports that you prefer be used by the spanning tree should have the lowest path cost.
Fast Start	Port transitions directly to forwarding without first learning the topology of the spanning tree. This is a non-standard implementation and should be used only when there is no possibility of creating a loop at this port. <u>Note:</u> Use this setting for end-station connections. It provides greatest compatibility with end-station adapters.

- 5 Click **Apply** to commit your changes.

Using Hunt Groups to Aggregate Bandwidth Between Switches

Why Use Hunt Groups?

Hunt groups allow you to aggregate multiple switch ports into a single group, effectively combining the bandwidth into a single connection. For example, if you connect three gigabit ports each on a pair of switches into a hunt group, the aggregated connection will have 6 gigabits of available bandwidth (full duplex).

Hunt groups also provide fault tolerance. If a port in a hunt group fails, the remaining ports will continue forwarding the traffic on the link.

What You Need to Know Before Configuring Hunt Groups

If you follow the procedures in this guide, hunt group configuration is a simple process:

- 1) Create hunt groups on the switches you are aggregating bandwidth between.
- 2) Assign ports to the hunt group.
- 3) Enable the ports.

There are, however, several things that you need to know before creating hunt groups:

- The switches do not yet have a link discovery protocol. When creating a hunt group, you have to verify that the ports in a hunt group on one switch are physically connected to the ports in that hunt group on the other switch.
- If one end of a connection is in a hunt group, the other end of the connection should be in the same hunt group. If you don't do this, the forwarding behavior of the hunt group will be unpredictable.
- You should disable the ports in a hunt group until both ends of the link are configured.
- All ports in a hunt group must be the same speed.

Using Hunt Groups to Aggregate Bandwidth Between Switches

Configuring Hunt Groups Using the Embedded Web Server

To configure an hunt group on the embedded server:

Step	Action
1	Make sure that the same-speed ports that you are configuring into a hunt group are physically connected to each other (for example, in a 4-port gigabit hunt group, make sure that you have four fiber cables with GIGAswitch/Ethernet system ports connected at each end).
2	If this is a new hunt group, disable all of the ports you are adding to the hunt group. If you are adding ports to an existing hunt group, disable the ports you are adding.
3	On the first switch, select Hunt Groups from the menu on the left side of the browser window. The first Hunt Group Configuration window displays. This window supports the features described below.

Hunt Group Configuration

Name	Flood Port	Load Sharing	Members
<input type="checkbox"/> Backbone	6.1	Enable	1

Button or Link	Function
Create button	Summons a screen that allows you to add new hunt groups.
Delete button	Deletes hunt groups that have a check next to the hunt group name.
Members link	Lists port numbers of ports that are members of the selected hunt group.
Redistribute button	Redistributes the hunt group learned addresses. Click this button if you notice that a particular link has learned too many of the busiest ports. The button causes the MAC addresses to be redistributed among the hunt group ports.

Using Hunt Groups to Aggregate Bandwidth Between Switches

Step	Action
4	To create a new hunt group, click Create . The second Hunt Group Configuration window displays.

Hunt Group Configuration

Attribute	Value
Name	<input type="text"/>
Flood Port	<input type="text"/> . <input type="text"/>
Load Sharing	<input type="text"/> Enable ▾

- 5 Enter a name for this end of hunt group in the **Name** field.
- 6 Enter a Flood Port number for the hunt group. The flood port carries all flood traffic for the group. It also carries all spanning tree BPDUs.
- 7 To enable load sharing, set the Load Sharing parameter to enable.
- 8 Click **Apply** to create the hunt group.

Adding Ports to a Hunt Group

Once you have created and named a hunt group, you can add as many additional ports as you would like to the group. To do this:

Step	Action
9	From the menu on the left side of the browser window, select Modules . A menu of modules displays.
10	Click on the number in the Ports column to display the ports menu.
11	Set the mode on the ports you are adding to the hunt group to disable , then click Apply .
12	Click the browser's Back button to return to the modules menu.

Using Hunt Groups to Aggregate Bandwidth Between Switches

Step	Action
13	From the table row that describes the module whose port you are adding to the hunt group, click the number in the switch ports column. The Switch Ports table displays.
14	Select Switch Ports on the row that corresponds with the port you want to configure. The Switch Ports Configuration window displays.

Switch Port Configuration 6.1 : Port 6.1

Port VLAN	Default ▾
Trunk Mode	Clear ▾
Frame Tags	Use ▾
VLAN Binding	Static ▾
Automatic VLAN Creation	Disable ▾
Allow Learning	Enable ▾
Hunt Group	[None] ▾
Spanning Tree Mode	Enable ▾
Known Mode	Disable ▾
Mirror Port	Disable

- 15 Use the drop-down menu to select the hunt group assignment of the port.
- 16 Click **Apply** to assign the selected port to the hunt group.
- 17 Repeat steps 9 through 16 for any additional ports you would like to add to this hunt group.
- 18 Repeat steps 3 to 17 on the switch at the other end of the hunt group connection.
- 19 Enable the ports in the hunt group. The hunt group begins functioning as a load-sharing connection.

Chapter 5

Tuning Your Switch Performance by Managing Buffers and Queues

Overview

Introduction

This chapter describes how to use the DIGITAL GIGAswitch/Ethernet system's buffer management features to optimize traffic throughput through the switch fabric.

In This Chapter

This chapter contains the following topics:

Topic	Page
Why Use Buffer Management?	5-2
Managing Buffers and Queues	5-4

Why Use Buffer Management?

Why Use Buffer Management?

There are two principal reasons for managing buffers in a switch:

- To make sure that the high-priority traffic is being processed as expected
- To make sure that buffers are not timing out too quickly when passing traffic to slower ports

The section that follows describes the GIGAswitch/Ethernet system buffer and queuing implementation.

How GIGAswitch/Ethernet System Queues Work

Frames are buffered in the I/O modules, before and after traversing the switch. Each queue can hold 256K bytes. (Architecturally, they can support up to 1 MB each).

GIGAswitch/Ethernet System Queues

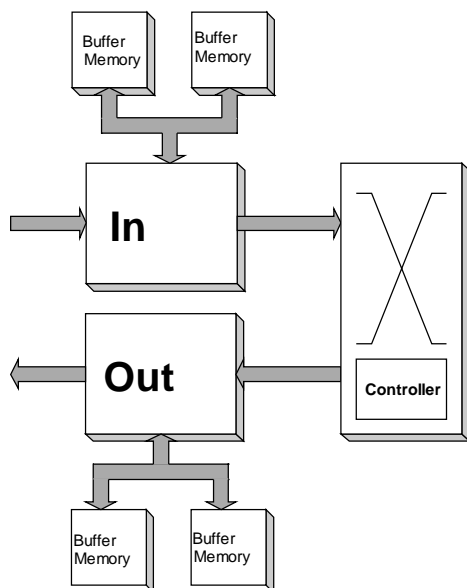

Why Use Buffer Management?

Each buffer is divided into two queues, one for high-priority traffic and one for normal-priority traffic. The factory default is for the high-priority queue to use 20% (51K) of the buffer. The normal-priority queue uses the remaining 80% (205K). These values can be modified using either the web agent or SNMP. When you change these values, you must reboot the switch before they can take effect.

Less buffer memory gets assigned to the high-priority queue because the high-priority queue gets serviced more frequently than the normal-priority queue. Since a frame spends less time on the high-priority queue, less buffer space is required for the queue.

The service ratio can be chosen to match traffic patterns and performance requirements using a weighted round robin scheduling algorithm. The available service ratios of the algorithm are defined in [Managing Buffers and Queues on page 5-4](#). The factory default service ratio is 99/1. If there is traffic to be serviced from both the high- and normal-priority queues, 99 packets of high-priority traffic will be processed for each normal-priority packet.

When the high-priority queue fills up, incoming frames are dropped. The philosophy is if a high-priority frame is going to be late, it is not worth sending it at all. The normal-priority queue uses either IEEE 802.3X PAUSE (variable timed XOFF) flow control or half-duplex collisions to shut off incoming frames before the queue overflows.

The GIGAswitch/Ethernet system implements two flow control disciplines along the entire path that frames travel. The default case is that when output buffers fill up, frames destined for a particular buffer will be dropped after being switched by the crossbar. This should occur only when the output port is very congested. However, there is an optional mode in which normal-priority frames are never dropped inside the switch. In this mode, input buffers may fill up. If they do, the affected input ports may use flow control to temporarily halt traffic from neighboring switches.

Managing Buffers and Queues

You can access the switch buffer management features from the Module Information menu. To manage buffers and queues:

Step	Action
1	From the menu on the left side of the web agent browser, select Modules & Ports . The Module Information screen displays.

Module Information

Slot	Model Number	Type	Ports	Switch Ports	Buffer Management	Name
<input type="checkbox"/> 1	DGBGL-AA	Switch Control Processor	1	1	Module 1	Module 1
<input type="checkbox"/> 2	DGBGL-AA	Gigabit	2	2	Module 2	Module 2
<input type="checkbox"/> 3	DGBGT-AA	Fast Ethernet	20	20	Module 3	Module 3
<input type="checkbox"/> 5	DGBGL-AA	Gigabit	2	2	Module 5	Module 5
<input type="checkbox"/> 6	DGBGT-AA	Fast Ethernet	20	20	Module 6	Module 6

- 2 Select the module name for the module whose buffers you want to manage. The buffer management window displays.

Buffer Management - Module 2

Fabric Port Buffers

[2.1](#)

[2.2](#)

[Prev Module](#)
[Next Module](#)
[Modules](#)

Managing Buffers and Queues

Step	Action
3	Select the Fabric Port whose associated buffers you want to manage. The information associated with the select fabric port displays.

Buffer Configuration - Module 2, Fabric Port 2

Input Buffer	
Memory	256 KB
Age Timer	160ms to 320ms ▾
High Priority Allocation	20% ▾
Priority Threshold	4 ▾
High Priority Service Ratio	999 to 1 ▾
High Overflow Drops	0
Overflow Drops	0
High Stale Drops	0
Stale Drops	0
Congestion Drops	0

Fabric Port Output Buffer	
Memory	256 KB
Age Timer	160ms to 320ms ▾
High Priority Allocation	40% ▾
Priority Threshold	4 ▾
High Priority Service Ratio	9999 to 1 ▾
High Overflow Drops	0
Overflow Drops	0
High Stale Drops	0
Stale Drops	0
Congestion Drops	0

The fields are defined in [Table 5-1](#).

Managing Buffers and Queues

Table 5-1: Buffer Management Table Definitions

Field	Definition
Memory	The amount of physical memory associated with this buffer.
Age Timer	The amount of time a packet remains in the queue before being discarded as a stale packet. You may want to increase the timer value for ports connected to 10 Mb/s ports, particularly 10 Mb/s shared media, because you may want to queue packets longer before discarding them.
High Priority Allocation	Percent of the buffer's queuing space allotted to high priority traffic. Because the high-priority queue is serviced more frequently than the normal priority queue, raising this value may not necessarily provide better service. In fact, if you are using the high-priority queue for delay-sensitive traffic, you may want to reduce the amount of memory devoted to the high-priority queue. This ensures that packets that cannot be delivered in a timely manner are discarded. If instead you want the high priority queue to guarantee delivery of as many packets as possible, regardless of delay, increase this value. The change does not take effect until you reset the switch.
Priority Threshold	Some priority schemes have more than two queues (the IEEE allows up to 8, numbered 0 through 7). Set this parameter to the value at which the GIGAswitch/Ethernet system starts sending packets to the high-priority queue. The default value (4) causes all traffic with a priority greater than 4 (5, 6, and 7) to be assigned to the high-priority queue.
High Priority Service Ratio	Determines how many times the high priority queue is serviced for each time the low priority queue is serviced. The ideal value changes from queue to queue, but the goal is to ensure that traffic mix guarantees optimal mix between high-priority and best effort traffic.

Table 5-1: Buffer Management Table Definitions (Continued)

Field	Definition
High and Normal Overflow Drops	Number of packets dropped because the associated buffer is full. Indicates that the device immediately before the queue is processing traffic faster than the next downstream element can process the same volume of traffic. For example, overflow drops on the input buffer indicate that traffic is arriving faster than the switch matrix can process it. Overflow drops on the output buffers indicates that the output port cannot handle the volume of the load being offered.
High and Normal Stale Drops	Number of packets dropped because they timed out waiting for service (using the age timer value). In the high-priority queue, this can help determine how efficiently the switch is processing “better never than late” traffic. Excessive stale drops on the high-priority queue may indicate the need to increase the service ratio on the high-priority queue.
Congestion Drops	Number of packets dropped because the switch controller has sensed congestion at the outbound port.

Additional Buffers on Fast Ethernet Ports

Fast Ethernet ports have additional buffers on both the input and output ports to help manage entry into the switch matrix and the potential for congestion caused by high volumes of traffic at the outbound port.

To tune the extra buffers:

Step	Action
1	Select the module name for the module whose buffers you want to manage. The buffer management window displays.

Buffer Management - Module 5

Fabric Port Buffers	Physical Port Buffers
5.1	5.1 5.2 5.3 5.4 5.5 5.6 5.7 5.8 5.9 5.10
5.2	5.11 5.12 5.13 5.14 5.15 5.16 5.17 5.18 5.19 5.20

[Prev Module](#) [Modules](#)

Managing Buffers and Queues

Step	Action
2	Click on the port whose buffers you want to manage. The Buffer Management Screen for that port displays.

Buffer Configuration - Module 6, Physical Port 1

Input Buffer	
Memory	16 KB
Age Timer	100ms to 200ms ▾
Overflow Drops	10
Stale Drops	10

Output Buffer	
Memory	116 KB
Age Timer	168ms ▾
High Priority Allocation	20% ▾
Priority Threshold	4 ▾
High Priority Service Ratio	1023 to 1 ▾
High Overflow Drops	0
Overflow Drops	0
High Stale Drops	0
Stale Drops	0

Associated Fabric Port: [6.1](#)

- 3 Refer to [Table 5-1 on page 5-6](#) for instructions on configuring the parameters on this screen.
-

Chapter 6

Managing Address Forwarding Tables

Overview

Introduction

This chapter describes how to manage the address forwarding tables in the DIGITAL GIGAswitch/Ethernet system. Managing address tables helps conserve memory space.

In This Chapter

This chapter contains the following topics:

Topic	Page
Configuring the Address Forwarding Table	6-2
Viewing the Switch Address Forwarding Table	6-5
Adding Entries to the Address Forwarding Table Manually	6-8

Configuring the Address Forwarding Table

You can configure the following when using the address forwarding table:

- **Address Age Time**, which defines the length of time addresses remain active in the address forwarding table
- **Super Age Time**, which defines how long inactive addresses are stored in the address forwarding table before being deleted
- **Address Table Sizing Parameters**, which allow you to adjust what the switch does when address table use becomes inefficient

The Address Forwarding Table screen also provides information useful when working with DIGITAL support personnel. This information is not useful during normal operation of the switch, and is not described in this guide.

Setting the Age Timer and Super Age Timer

To change the aging values for all instances of the address table:

Step	Action
1	From the web agent window, select Table Configuration. The AFT Table Configuration window displays.

AFT Table Configuration

Address Table Parameters

Total AFT Entries	Age Time	Super Age Time	Address Memory			Auto-Sizing	
			Used	Available	Largest Contiguous	Threshold (Util%)	Trigger (Util%)
56	300 seconds	7 days	3136	58304	8192	40 %	12%

Instance Table Information

Instance ID	Hash Table Size	Number AFT Entries	Bucket Capacity	Bucket Utilization
1	1024	20	21	95%
7	1024	18	19	94%
8	1024	18	19	94%

Configuring the Address Forwarding Table

Step	Action
2	Change the Age Time by typing a new value at the Age Time prompt. The default of 300 seconds is the standards-recommended default. Aged out addresses become invalid until the switch sees another packet with the aged out entry's source address.
3	Change the Super Age Time by typing a new value at the Super Age Time prompt. The Super Age Timer marks all invalid table entries, then checks to see if they remain invalid for the specified super age interval. This helps to clear the table of entries that are no longer used.
4	Click Apply to make the changes.

Controlling Reconfiguration of Address Table Sizes

Each VLAN you define creates a separate version of the switch address forwarding table. When these address tables become large, they may begin to use address space inefficiently.

If you leave the switch in its default state, it will adjust for growth automatically. However, this will lead to a few seconds of flooding packets when the address table reconfigures. If you want to control manually when this flood event occurs:

Step	Action
1	From the web agent window, select Table Configuration . The AFT Table Configuration window displays.
2	If you just want to cause the table reconfiguration to occur at a different level of usage efficiency, change the Auto-Sizing Utilization Threshold. The default value of 40% is recommended for most applications. Raising the value might cause the table to be relearned more frequently, and will make address space usage more efficient.

Configuring the Address Forwarding Table

Step	Action
3	To achieve finer control of particular tables, select one of the Instance IDs from the first column in the lower table on the display. The AFT Instance table displays.

AFT Instance 1

VLAN Association		Default
Total Number of Entries		20
Entry Type	Learn	0
	Management	0
	Self	20
Entry Validity	Valid	20
	Invalid	0
Hash Table	Size	1024 ▾
	Auto Increment	true ▾
Bucket Info	Count	11
	Capacity	21
	Utilization	95%

- 4 To prevent the table size from reconfiguring automatically, change Auto Increment Table Size to **false**.
- 5 To alter the space available for this address table, change the Hash Table Size. The rule of thumb is: Tables with high Total Bucket Utilization (greater than 75%) can be made smaller. Tables with low Total Bucket Utilization (less than 40%) should be made larger.
- 6 Click **Apply** to make the changes. If you have changed the Hash Table Size, the switch will relearn all address in that table, causing the switch to flood packets for a few seconds.
- 7 If you want to relearn the entire table, select **DELETE ALL LEARNED ENTRIES**.
- 8 If you want to delete all entries that are currently aged out, select **DELETE ALL INVALID LEARNED ENTRIES**.

Viewing the Switch Address Forwarding Table

To view the switch address forwarding table in a switch:

Step	Action
1	Log in to the switch-based web agent using your web browser.
2	From the menu on the left side of the browser, select Entry Search .

Displaying the Address Forwarding Table

The address forwarding table can contain more than 16,000 entries on each switch. The switch web agent provides a utility that allows you to filter which addresses it displays, making the list more manageable. Multiple criteria can be selected to produce a sophisticated filter. The parameters are treated as “ands,” meaning that displayed addresses must meet all selected criteria. To filter the address forwarding table:

Step	Action
1	Click Entry Search on the menu on the left side of the web browser display. The Address Entry Search screen displays.

Address Entry Search

Total AFT Entries: 56

Entry Search Criteria	
Search By:	Search Value:
<input type="checkbox"/> MAC Address	<input type="text" value=""/> : <input type="text" value=""/> : <input type="text" value=""/> : <input type="text" value=""/> : <input type="text" value=""/> : <input type="text" value=""/>
<input type="checkbox"/> VLAN	<input type="text" value="Default"/> ▾
<input type="checkbox"/> SwitchPort	<input type="text" value="forward"/> ▾ <input type="text" value=""/> . <input type="text" value=""/>
<input type="checkbox"/> Status	<input type="text" value="learn"/> ▾

Note: The search ignores any parameter not checked in the left column. To view all addresses in the table, click search without selecting any filters.

Viewing the Switch Address Forwarding Table

Step	Action
2	To use a MAC address as the criteria for the search, click in the box next to MAC Address and enter a MAC address in the field.
3	To search for ports associated with a particular VLAN, click in the box next to VLAN and select a VLAN name from the drop-down list.
4	To display only entries associated with a particular switch port, click in the box next to Switch Port and enter a slot and port number.
5	To show only switch ports of a particular bridging status, click in the box next to Status and select a status from the drop-down list.
6	Click Search to display the Address Table Entries that meet the criteria you selected, or select Cancel to clear the form. A list of MAC addresses in the switch address forwarding table displays.

Index	MAC Address	SwitchPort	Valid	Group	TblInst	Priority	Persistence	Status
18	01:80:C2:00:00:00	cpu	Valid	2	2	high	permanent	Self
19	01:80:C2:00:00:01	filter	Valid	2	2	normal	permanent	Self
20	01:80:C2:00:00:02	filter	Valid	2	2	normal	permanent	Self
21	01:80:C2:00:00:03	filter	Valid	2	2	normal	permanent	Self
22	01:80:C2:00:00:04	filter	Valid	2	2	normal	permanent	Self
23	01:80:C2:00:00:05	filter	Valid	2	2	normal	permanent	Self
24	01:80:C2:00:00:06	filter	Valid	2	2	normal	permanent	Self
25	01:80:C2:00:00:07	filter	Valid	2	2	normal	permanent	Self

The columns in the table are defined in [Table 6-1](#).

Viewing the Switch Address Forwarding Table

Table 6-1: Address Table Column Definitions

Column	Definition
Index	The index number of this address entry in the switch address forwarding table.
MAC Address	The MAC address associated with this entry. This address has been learned by the switch as an address to forward to the associated port.
Switch Port	The Switch Port associated with this address table entry.
Priority	The priority level associated with traffic forwarded to this MAC address. The options are Normal and High . This parameter is settable on all learned entries.
Persistence	The persistence of the entry in the table (settable on all learned entries): Permanent: The address is not aged out of the table. Invalid: This entry is cleared from the table each time the switch resets. Ageout: Address is cleared from the address forwarding table when the timeout interval expires. This is the state of all entries dynamically learned by the switch. It ensures that MAC addresses that are not active on the network do not remain in the switch address forwarding table indefinitely.

Note: The Address Forwarding Table screen also provides information useful when working with DIGITAL support personnel. This information is not useful during normal operation of the switch, and is not described above.

Adding Entries to the Address Forwarding Table Manually

Use the Static Address Configuration screen to add entries to the switch address forwarding table manually. This feature is particularly useful for adding entries that you want to ensure remain in the address forwarding table permanently. To add an address manually:

Step	Action
1	Select Entry Configuration under Address Forwarding in the menu on the left side of the browser screen. The Static Address Configuration window displays.

Attribute	Value
MAC Address	<input type="text"/> : <input type="text"/> : <input type="text"/> : <input type="text"/> : <input type="text"/> : <input type="text"/>
VLAN	Engineering ▾
Switch Port Binding	forward ▾ <input type="text"/> . <input type="text"/>
Priority	normal ▾
Persistence	permanent ▾

APPLY CANCEL

- 2 Enter the MAC address that you want to add to the table, then press **Tab**.
- 3 Select a VLAN for this entry from the drop-down list, then press **Tab**.
- 4 Enter the switch port that you want associated with this entry in the Switch Port Binding field, then press **Tab**.
- 5 Select a priority level for packets forward to this MAC address, then press **Tab**. The options are normal and high. High priority addresses move to the front of the switch packet buffers automatically.

Adding Entries to the Address Forwarding Table Manually

Step	Action				
6	Select a persistence for this entry, the options are: <table border="1"><tbody><tr><td>Permanent</td><td>The address is saved in non-volatile memory and is not aged out of the table.</td></tr><tr><td>Ageout</td><td>Address is cleared from the address forwarding table when the timeout interval expires. This is the state of all entries dynamically learned by the switch. It ensures that MAC addresses that are not active on the network do not remain in the switch address forwarding table indefinitely.</td></tr></tbody></table>	Permanent	The address is saved in non-volatile memory and is not aged out of the table.	Ageout	Address is cleared from the address forwarding table when the timeout interval expires. This is the state of all entries dynamically learned by the switch. It ensures that MAC addresses that are not active on the network do not remain in the switch address forwarding table indefinitely.
Permanent	The address is saved in non-volatile memory and is not aged out of the table.				
Ageout	Address is cleared from the address forwarding table when the timeout interval expires. This is the state of all entries dynamically learned by the switch. It ensures that MAC addresses that are not active on the network do not remain in the switch address forwarding table indefinitely.				
7	Click Apply to add the entry to the table.				

Chapter 7

Monitoring GIGAswitch/Ethernet System Health

Overview

Introduction

This chapter describes how to assess the DIGITAL GIGAswitch/Ethernet system's current operational status.

In This Chapter

This chapter contains the following topics:

Topic	Page
Interpreting Front Panel LED Displays	7-2
Checking Temperature Status and Setting Thresholds	7-3
Checking Active Alarms	7-5
Setting Log Size and Activating System Events	7-5
Using the Switch Event and Shutdown Logs	7-9

Interpreting Front Panel LED Displays

Table 7-1 lists the definition for each state of the front-panel LEDs.

Table 7-1: Front Panel LED Display Interpretation

Module	LED	Behavior	Indicates
All modules	Module Status	Solid green	Normal operation.
		Flashing yellow	Diagnostic failure.
		Off	Module not operational or not receiving power.
Gigabit modules	TX and RX	Solid green	Normal operation.
		Solid green/ flashing yellow	Port receiving traffic.
		Flashing yellow	Hardware failure.
		Off	No link.
	Port	Solid green	Port enabled with link up.
		Flashing green	Port disabled with link up.
		Flashing yellow	Hardware failure.
		Off	No link.
	HD/FD	Solid green	Full-duplex operation negotiated.
		Flashing yellow	Hardware failure.
		Off	No link.
	10/100 modules	Port	Solid green, with yellow flash
Flashing green			Port disabled with link up.
Flashing yellow			Hardware failure.
Off			No link.

NOTE

Contact your DIGITAL service representative if your system indicates a failure.

Checking Temperature Status and Setting Thresholds

The GIGAswitch/Ethernet system lets you check the temperature status of the switch, and set up an alarm that sends a trap message when temperature thresholds are exceeded. To view the Temperature System:

Step	Action
1	Click Temperature in the menu on the left side of the browser. The Temperature System screen displays.

Temperature System

	Probe #1	Probe #2
High Shutdown Temperature	50 °C	50 °C
Upper Warning Temperature	45 °C	45 °C
Current Temperature	27 °C	37 °C
Lower Warning Temperature	5 °C	5 °C
Low Shutdown Temperature	0 °C	0 °C
<input type="button" value="DEFAULTS"/>	<input type="button" value="APPLY-1"/>	<input type="button" value="APPLY-2"/>

2	Set the threshold values as defined in Table 7-2 .
---	--

Checking Temperature Status and Setting Thresholds

Table 7-2: Temperature Thresholds

Threshold	Definition
High Shutdown Temperature	The value in degrees Celsius that, when passed, causes the switch to send a trap to the network management station.
Upper Warning Temperature	The value in degrees Celsius that, when passed, causes the switch to send a warning that the temperature is approaching the high temperature threshold.
Lower Warning Temperature	The value that in degree Celsius that, when passed, causes the switch to send a warning that the temperature is approaching the low temperature threshold.
Low Shutdown Temperature	Set this threshold to determine how low the temperature must drop on the switch to reset the warning and high thresholds. This value prevents the switch from sending traps continually if the temperature is hovering around the threshold value.

When the switch exceeds a temperature threshold, that event is listed in the Event Log. If that event is 1 of the 16 most recent switch events when the switch shuts down, the event is also listed in the Shutdown Log. See [Using the Switch Event and Shutdown Logs on page 7-9](#) for information about viewing these logs.

Checking Active Alarms

Each switch stores a table of active alarms. This allows you to view a list of “open issues” in the switch without having to view the entire event log. By doing this, you can quickly obtain a snapshot of the switch’s health.

Viewing the Active Alarm Table from the Web Agent

To view the Active Alarm Table from the web agent:

Step	Action
1	Launch your browser using the switch IP address as your destination.
2	Log in to the web agent.
3	Select Active Alarms from the menu on the left-hand side of the browser window. The active alarms list displays.

Setting Log Size and Activating System Events

The GIGAswitch/Ethernet system lets you set the amount of entries stored in the switch logs, and to configure and activate system events. To do this:

Step	Action
1	Select Event Configuration from the menu on the left side of the browser window. The Event Management window displays.

Event Management

Event Log Parameters

Log	Max Log Entries
Event Log	512
Shutdown Log	16

Event Table

ID	Name	Mode	Action	Time Last Triggered	Trap Receiver	Owner
<input type="checkbox"/> 1	Start	Enable	<input checked="" type="checkbox"/> Log <input checked="" type="checkbox"/> Trap <input type="checkbox"/> Console	97-Nov-26 15:28:53	[All Trap Receivers]	System
<input type="checkbox"/> 2	System	Enable	<input checked="" type="checkbox"/> Log <input checked="" type="checkbox"/> Trap <input checked="" type="checkbox"/> Console	[Never Triggered]	[All Trap Receivers]	System

- 2 Select the number of entries you want to store in each of the switch event logs. The logs are described in [Table 7-3](#). You select a size for each log from the drop-down lists. Reasons to adjust:
 - Your application requires more entries (so you increase the size).
 - You want to limit the amount of system resources used by a log (and, therefore, decrease the size).
- 3 Click **Apply** to change the log sizes. Click **Cancel** to redisplay the current switch setting for these values.
- 4 The system also has five event classes that you can configure actions for. The event classes are defined in [Table 7-4](#).

Setting Log Size and Activating System Events

Table 7-3: Event and Shutdown Logs

Log	Purpose
Event Log	A detailed, ongoing record of events that occur in the switch. This log is stored in memory and is erased if the system shuts down or reboots.
Shutdown Log	Contains a list of events that occurred before the last switch shutdown. Because it is stored in non-volatile memory, this log is preserved during a switch reboot or shutdown. This list is designed to help analyze the events that occurred immediately prior to a switch shutdown or reset.

Table 7-4: Event Classes

Event Class	Definition
Start	Determines whether or not the switch sends a notification upon system start, and how the notification is sent.
System	Determines whether or not the switch sends a notification during system events, and how the notification is sent.
Config	Determines whether or not the switch sends a notification for each configuration change (enabling and disabling ports, for example), and how the notification is sent.
Status	Determines whether or not the switch sends a notification of system status changes, and how the notification is sent. Generally triggered by status-related alarms.
Resource	Determines whether or not the switch sends a notification upon a change in system resources, and how the notification is sent.

Setting Log Size and Activating System Events

Step	Action
5	To edit the settings for these event types: <ul style="list-style-type: none">a) Click the box next to the event type you want to change settings for.b) Use the enable/disable pulldown to enable or disable delivery of event information when this type of event occurs.c) Select where you want event information sent, as defined in Table 7-5.

Table 7-5: Event Table Actions

Setting	Causes
Log	Event entry sent to event and shutdown logs.
Trap	Trap message (event notification) sent to designated trap receivers.
Console	Sends the event information to the console connected at the switch front panel.

- 6 Click **Apply** to commit the changes. Click **Cancel** to redisplay the current switch setting for these values.

Using the Switch Event and Shutdown Logs

Each GIGAswitch/Ethernet System switch provides two logs of switch system activity:

- **Event Log**, which stores a large table of events. The size of the table is user-settable. Because these events are stored in switch memory, the list is cleared each time the switch reboots.
- **Shutdown Log**, which stores the same information as the Event Log, but generally in a smaller table because the table is stored in the switch's nonvolatile RAM (NVRAM). This log list is particularly useful in assessing the cause of a switch failure, because the information is retained even after the switch restarts.

To view the logs:

Step	Action
1	From the menu on the left side of the browser window, select either Event Log or Shutdown Log . A search screen displays.

Event Log

Entry Search Criteria

Search By:	Search Value:
<input type="checkbox"/> Severity Level:	normal
<input type="checkbox"/> Event Type:	cold start

SEARCH CANCEL

- | | |
|---|---|
| 2 | To filter on a particular severity level for events, select a Severity Level from the drop-down list. |
|---|---|

Using the Switch Event and Shutdown Logs

Step	Action
3	To filter on a particular Event Type, select an event type from the drop-down list. The selected log entries display. The columns are defined in Table 7-6 .

Log ID	Event ID	Time Stamp	Severity	Type	Description
1	1	32-Jan-00 00:00:00	Informative(20)	Coldstart	System started at 48-Dec-20 20:16:36
2	5	32-May-00 00:00:00	Informative(20)	New Resource	New Resource: Module 1. [Module1]
3	5	32-May-00 00:00:00	Informative(20)	New Resource	New Resource: Module 5. [Module5]
4	4	32-Apr-00 00:00:32	Alarm(60)	Status Change	Status = Link Failure : Port 5.2. [Port5.2]
5	4	32-Apr-00 00:00:32	Informative(20)	Status Change	Status = Okay : Port 5.2. [Port5.2]

Table 7-6: Event and Shutdown Log Entries

Column	Definition
Log ID	The number of this event in the log FIFO.
Event ID	An index that identifies the event type.
Time Stamp	The date and time the event was recorded in the log.
Severity	The severity of the event. The possibilities are: Informative, Warning, Error, Severe Error, and Failure.
Type	A description of the event type (System start, Status Change, for example).
Description	A text string that describes the specific event.

Chapter 8

Analyzing Network Performance Using RMON and Ethernet Statistics

Overview

Introduction

This chapter describes the implications of statistics counter values displayed in a switch. The GIGAswitch/Ethernet system supports a variety of statistical views to help you analyze network performance.

In This Chapter

This chapter contains the following topics:

Topic	Page
Viewing Statistics	8-2
Intpreting Statistics	8-6
Setting Up a Mirror Port	8-11

Viewing Statistics

The switch interface provides a variety of statistics that allow you to monitor network performance and troubleshoot network problems. See [Table 8-1 on page 8-6](#) for interpretations of particular statistics. To access network statistics:

Step	Action
1	Select Modules & Ports under Statistics from the menu on the left side of the web agent browser. The module statistics menu displays.

Module	Type	Receive					Transmit				
		Bytes	Unicast Packets	Multicast Packets	Discards	Errors	Bytes	Unicast Packets	Multicast Packets	Discards	Errors
Module 1	Raw	0	0	0	0	0	0	0	0	0	0
	Normalized	0	0	0	0	0	0	0	0	0	0
Module 6	Raw	14,480	0	40	0	0	17,050	0	55	0	0
	Normalized	14,480	0	40	0	0	17,050	0	55	0	0

- 2 If you want to get a fresh look at statistics being gathered, click **Clear Counters**. This resets all of the counters in the Normalized rows to zero, so that you can track the counters from a particular point forward.

Viewing Statistics

- | Step | Action |
|------|---|
| 3 | To view statistics for a particular port on a module, click the module's identification in the left column of the Module Statistics display. The Port Statistics window for the selected module displays. |

Port	Type	Receive						Transmit					
		Utilization	Bytes	Unicast Packets	Multicast Packets	Discards	Errors	Utilization	Bytes	Unicast Packets	Multicast Packets	Discards	Errors
Port 6.1	Raw	N/A	724	0	2	0	0	N/A	1,162	0	4	0	0
	Since 97-Nov-26 15:28:56	0%	724	0	2	0	0	0%	1,162	0	4	0	0
Port 6.2	Raw	N/A	724	0	2	0	0	N/A	1,162	0	4	0	0
	Since 97-Nov-26 15:28:56	0%	724	0	2	0	0	0%	1,162	0	4	0	0
Port 6.3	Raw	N/A	724	0	2	0	0	N/A	1,162	0	4	0	0
	Since 97-Nov-26 15:28:56	0%	724	0	2	0	0	0%	1,162	0	4	0	0

- 4 If you want to get a fresh look at statistics being gathered, click **Clear Counters**. This resets all of the counters in the Normalized rows to zero so that you can track the counters from a particular point forward.

Viewing Statistics

Step	Action
5	To view detailed statistics for a particular port, click on the port identifier in the left column of the table. The Ethernet Interface Statistics for the port display.

Ethernet Interface Statistics: Port 6.1 -- Cleared 97-Oct-31 17:59:35

Available
History
Links
(mm:ss) :

[0:30 sample](#)
[30:0 sample](#)

Ethernet Interface Statistics

Counter	Type	Total	Receive	Transmit
Bytes	Raw	1,512	724	788
	Normalized	1,512	724	788
Unicast Packets	Raw	1	0	1
	Normalized	1	0	1
Multicast Packets	Raw	4	2	2
	Normalized	4	2	2
Discards	Raw	0	0	0
	Normalized	0	0	0
Errors	Raw	0	0	0
	Normalized	0	0	0

Error Detail

CRC Errors	Alignment Errors	Undersized Packets	Fragments	Oversized Packets	Jabbers	SQE Test Errors	Carrier Sense Errors
0	0	0	0	0	0	0	0

Error Detail

Total Collisions	Excessive Collisions	Late Collisions	Single Collisions	Multiple Collisions
0	0	0	0	0

Ethernet Interface Histogram

Packets per Octet Size	Total	Receive	Transmit
64	1	0	1
65 to 127	0	0	0
128 to 255	0	0	0
256 to 511	4	2	2
512 to 1023	0	0	0
1024 to 1518	0	0	0

Viewing Statistics

Step	Action
6	At the top of the Ethernet Interface Statistics display, you can choose to look at either 30 second or 30 minute RMON History Samples.

Ethernet Interface Module 6, Port 3 (6.3)												
History at 00:30 interval (mm:ss)												
Sample	Interval Start	Utilization	Bytes	Packets	Broadcasts	Multicasts	CRC or Alignment Errors	Undersized Packets	Oversized Packets	Fragments	Jabbers	Collisions
2401	97-Nov-01 14:50:16	0%	98918	908	15	16	0	0	0	0	0	0
2400	97-Nov-01 14:49:45	0%	60496	831	4	17	0	0	0	0	0	0
2399	97-Nov-01 14:49:14	0%	64536	856	3	16	0	0	0	0	0	0
2398	97-Nov-01 14:48:43	0%	60680	835	3	15	0	0	0	0	0	0

7	Refer to Table 8-1 on page 8-6 for information on interpreting statistics values.
---	---

Intpreting Statistics

Table 8-1 lists suggestions on interpreting statistics.

Table 8-1: Interpreting Ethernet Statistics

Statistic	Indicates	Actions
Drop Events (Missed Packets)	Counts the number of times that the RMON probe or Ethernet interface detects that it has missed traffic. These event occur when traffic on a segment has surpassed the interface's ability to process it.	<p>Make sure that the interface has flow control enabled. This prevents the port buffers from overflowing, but may cause roving congestion in the network.</p> <p>Set the port's known mode to enable. This causes the port to discard unknown multicast packets.</p> <p>Configure the Rate Limit feature, which limits the amount of flood packets processed by the port.</p> <p>Reduce the number of stations on the network segment.</p>
Bytes	Counts the raw number of octets received at the interface. Provides some indication of the amount of network bandwidth being used.	A sharp increase could indicate a need to reconfigure the network.
Packets	Counts the raw number of readable Ethernet packets of legal length received at the interface.	A sharp increase could indicate a need to reconfigure the network. (Octets are a better indication of bandwidth utilization, however.)

Table 8-1: Interpreting Ethernet Statistics (Continued)

Statistic	Indicates	Actions
Broadcast Packets	Broadcast packets are a normal part of network operation. For example, IP networks use broadcasts as part of Address Resolution Protocol (ARP) to resolve network addresses.	<p>Broadcasts cause every host on a network segment to process the packet.</p> <p>Use monitoring to help you to recognize oncoming broadcast storms. Broadcast storms occur when stations are creating traffic that by its nature generates more traffic.</p> <p>To prevent broadcast storms, use VLANs to limit the area of the network that each broadcast packet affects. In general, each VLAN creates a separate broadcast domains. More VLANs mean less proliferation of broadcast packets.</p> <p>Monitor the broadcast rate of your network during normal operation. Establish a baseline. Create a threshold that sends a notification of unusual activity.</p> <p>Use rate limiting.</p>
Multicast Packets	Normal during network operation. For example, multicast packets are used to send target video streams to selected stations on the network, and are part of the operation of Spanning Tree Protocols.	<p>Like broadcast packets, too many multicast frames can consume valuable network bandwidth.</p> <p>The switch supports group multicast session schemes. Using software that supports these schemes can significantly reduce multicast traffic.</p> <p>Segmenting the network into smaller VLANs and routing between them can also help control proliferation of multicasts.</p> <p>Use rate limiting.</p>

Intrepreting Statistics

Table 8-1: Interpreting Ethernet Statistics (Continued)

Statistic	Indicates	Actions
<p>CRC Alignment Errors</p>	<p>Count of the number of times that the number of bits in a frame cannot be divided by 8 (that is, cannot be broken into legal octets), and that contain a Frame Check Sequence validation error. Typically caused by turning equipment on or off, and by noise on twisted pair segments. These errors can also result from configuring a network that does not comply with 802.3 standards. In a standards-compliant Ethernet network, CRC or alignment errors represent transit and receive bit errors.</p> <p>The Ethernet standard allows 1 in 10^8 bit error rate, but you should expect performance to be less than 1 in 10^{12} packets. Rates in excess of one error per one thousand packets indicate a serious problem.</p>	<p>Cause: Defect at the transmitting station.</p> <p>Action: Use port error statistics to isolate the problem. Check the transceiver or adapter card connected to the port where the problem seems to originate. Also check the cable and cable connections for damage.</p> <p>Cause: Turning equipment on or off. This should cause only a few errors.</p> <p>Action: Normal operation, no action required.</p> <p>Cause: Damaged cables.</p> <p>Action: Check cables for damage.</p> <p>Cause: Interference on network cabling.</p> <p>Action: Inspect cable runs to see if they are too close to noisy devices, and check for problems with network devices.</p>
<p>Undersize and Oversize Packets</p>	<p>Counts malformed packets that are most often the result of software errors.</p>	<p>Cause: A transceiver on your network is adding bits to the packets transmitted by the attached station.</p> <p>Action: Use a network analyzer to identify the transceiver which is causing the problem. If necessary, replace transceiver, network adapter, or station.</p> <p>Cause: There is excessive noise on the cable.</p> <p>Action: Check for cables too close to noisy electronic equipment, improper cabling, damaged cable, or malfunctioning network equipment.</p>

Table 8-1: Interpreting Ethernet Statistics (Continued)

Statistic	Indicates	Actions
Fragments	Fragments or runts result from normal collision activity in Ethernet networks. A runt packet is an incomplete packet that is long enough to be detected by an Ethernet interface.	<p>Cause: Interference on network cabling.</p> <p>Action: Inspect cable runs to see if they are too close to noisy devices, and check for problems with network devices.</p> <p>Cause: A Transceiver attached to the Repeater is generating Signal Quality Errors (SQE).</p> <p>Action: Disable SQE on the Transceiver.</p>
Jabbers	Jabbers indicate that devices on the networks are sending improper electrical signals. Because Ethernet uses electrical signalling to determine whether or not it is okay to transmit, a jabber condition can halt all traffic on a segment.	<p>Cause: Bad network interface card.</p> <p>Action: Replace network interface card.</p>
Collisions	<p>Counts number of times that packets have collided on the network. Collisions increase as network use of shared segments increases. Therefore, if the collision rate increases without an increase of network use, it might indicate a problem. Guidelines for appropriate collision rates are as follows:</p> <p>10 percent: Normal collision rate for shared Ethernet segment.</p> <p>30 percent: Collisions begin to interfere with performance.</p> <p>70 percent: Practical limit for network to remain functioning.</p> <p>A full-duplex link should not show collision activity</p> <p>In a switched network, collisions should be rare, unless your switched segments attach to multiple ends stations (a perfectly legal configuration option).</p>	<p>Cause: Busy network.</p> <p>Action: If you have multiple stations on a switch segment, reconfigure network into segments with fewer stations.</p> <p>Cause: Broken adapter (not listening before broadcasting).</p> <p>Action: Isolate each adapter to see if the problem ceases.</p> <p>Cause: Network loop.</p> <p>Action: Activate spanning tree to resolve loops automatically.</p> <p>Check that there are no connections to the same station where both connections are active simultaneously.</p>

Intpreting Statistics

Table 8-1: Interpreting Ethernet Statistics (Continued)

Statistic	Indicates	Actions
Packet Distribution Stats	<p>Provides counters that display the number of packets in different size groups. The size groups allow the network administrator to visualize the type of packets being sent over the network, and allow him or her to tune network parameters (buffer sizes) accordingly.</p> <p>Typically, file transfers use larger buffer sizes, while network housekeeping traffic (such as ARPs) use very small buffers.</p>	None.

Setting Up a Mirror Port

Configuring an RMON mirror port allows you to mirror traffic from a port or set of ports to a specific mirror port, where you can attach a sniffer or RMON probe. The switch supports a single mirror port and a single source port for each switch fabric port. For example, 20-port Fast Ethernet modules have 2 fabric ports (one for ports 1 through 10, one for ports 11 through 20). You can set up a single source port and a single mirror port for each set of ports associated with a fabric port. You can also choose to mirror all traffic from a particular fabric port to the mirror port. You can also set up multiple source ports to mirror traffic to a single mirror port.

This structure sounds complicated, but the interface enforces the rules automatically.

To set up an RMON mirror port:

- | Step | Action |
|------|---|
| 1 | Select Sampling from the menu on the left side of the web agent browser. The Port Mirroring Information screen displays. |

Port Mirroring Information						
Configure Source	Source Port	Mirror Port	Mirror Port Name	Sampler Type	Sampling Interval	
<input type="checkbox"/>	6.1-6.10	6.6	6.4	Port 6.4	Disable	-
<input type="checkbox"/>	6.11-6.20	-	-	-	-	-

Setting Up a Mirror Port

Step	Action
2	Select a source port for the traffic by clicking the appropriate selection in the Configure Source column. The Port Mirroring Configuration screen displays.

Port Mirroring Configuration

Source Port		Mirror Port	Sampler Type	Max Packets per Second
Slot	Port(s)			
3	1 ▼	3.1 ▼	Disable ▼	0

3 Use [Table 8-2](#) to select options for the mirror port.

Table 8-2: RMON Mirror Port Configuration Values

Column	Definition
Slot	Slot containing the port you are configuring.
Ports	List of available selections. Lets you select a particular source port associated with the selected fabric port. You can also select all ports.
Mirror Port	Port that you want to send the traffic from the source port or ports to. This port can be on another module in the switch. Once a particular port associated with a fabric port has been designated a mirror port, other ports associated with that fabric port no longer display on the selection list.
Sampler Type	Selects how often you want the mirror port to receive traffic samples: Always (sends all samples), Periodic (sends samples at the interval described below), Disabled (shuts off traffic samples to the mirror port, but keeps the association intact).
Max Packets per Second	Maximum number of packets that you want sent to the mirror port each second. Use this setting to control the size of samples sent to slower-speed RMON probe devices.

Appendix A

Downloading GIGAswitch/Ethernet System Firmware

Overview

Introduction

This appendix explains how to update the firmware (operational code, or image) for the DIGITAL GIGAswitch/Ethernet system — either to correct a problem or add new features.

In This Appendix

This appendix contains the following topics:

Topic	Page
Upgrade Process	A-2
Preparing for the Download	A-3
Downloading the New Firmware	A-4

Upgrade Process

You can download new firmware to the switch inband over the network. The process is:

Task	Description
1	Identify a TFTP server on your network.
2	Copy the new firmware file to the TFTP server.
3	Identify the location of the TFTP server using the FEPROM Update screen.
4	Select the appropriate download location.
5	Start the download.
6	When the download completes successfully, reboot the switch.

NOTE

For information about firmware upgrades, see the DIGITAL Network Products Home Page ([page xiv](#)).

Preparing for the Download

To prepare for the download procedure:

Step	Action
1	Make sure that you have a TFTP server available from which to download.
2	Copy the new firmware file to a location on the network that you can access from the TFTP server.
3	Make sure that the TFTP server station can connect to the switch (a ping to the switch IP address is a good way to do this).
4	Check the current versions of loaded firmware image by clicking FEPRM Contents . The FEPRM Contents window displays.

FEPRM Contents

Designator	Max Size	Actual Size	S/W Version
BOOT	512KB	339KB	b1.00.1
APP1	1536KB	678KB	b1.00.20
APP2	2048KB	1940KB	v1.00.0
FEPRM Size:		4 MBytes	

Power-Up/Reset Image

APP2 ▼

Apply

- 5 Decide which version of the firmware you want to keep as a backup in the event of problems with the newly downloaded image, and make sure that you download to the other APP area.
 - 6 Select which image area you want the switch to reboot with, then click **Apply**. For example, if you are downloading the new image to APP2, and want to reboot into the new image after the download, select APP2.
-

Downloading the New Firmware

To download the new firmware:

Step	Action
1	Log in to the switch using the embedded web agent.
2	From the menu on the left side of the Web browser, select TFTP Download (you may have to scroll because it is the last item on the menu). The FEPROM Update Screen displays.

FEPROM Update

TFTP Server IP Address	<input type="text" value="127.117.106.123"/>
Download File Name	<input type="text" value="flash_v101.bin"/>
FEPROM Target Section	<input type="text" value="APP2"/>

- 3 Enter the IP address of the computer running the TFTP server software at the **TFTP Server IP Address** prompt.
- 4 Enter the path and file name for the firmware at the **Download File Name** prompt.
- 5 At the **FEPROM Target Section** prompt, use the pulldown menu to select either APP1 or APP2. This ensures that the switch downloads the file to the correct memory location. You can check which versions of the code are loaded in the switch currently by clicking **Status**.
- 6 Click **Update**. The download begins.

Downloading the New Firmware

Step	Action
7	Click Status to display the current progress of the download in the Status area at the bottom of the browser display.
8	When the download completes, activate the new firmware as described in Preparing for the Download on page A-3 , then reboot the switch. As the switch initializes, the new software revision should display on the switch control processor's scrolling LED display.

Appendix B

Using the Command Line Interface

Overview

Introduction

This appendix describes how to use the embedded command line interface of the DIGITAL GIGAswitch/Ethernet system to perform a subset of the switch feature set.

In This Appendix

This appendix contains the following topics:

Topic	Page
Interface Features	B-3
Using the Interface	B-4
Commands	
Community	B-6
Console	B-8
Download	B-9
Event	B-10
Exit	B-11
Feprom	B-12
Module	B-13
Net	B-14
NVRAM	B-16

Topic	Page
Commands (Continued)	
Pause	B-17
Ping	B-18
Port	B-19
Reset	B-20
Rtc	B-21
Setup	B-22
Stack	B-23
Telnet	B-24
User	B-25
Verbose	B-27
VLAN	B-28

Interface Features

The switch command line interface provides the following features:

- Initial configuration needed to get communications working — IP, community, serial port configuration
- Basic configuration of system: basic show commands for module and port and basic port configuration (enable/disable)
- Basic system health
- Event system to display log and alarm information

This interface is available from the serial port (RS-232), or using Telnet.

Using the Interface

The command line interface works like a command line parser, but it also provides a menu-like interface to help guide the user through the selection process.

On startup, the system displays the following:

```
Digital Equipment Corporation GIGAswitch/Ethernet Agent v1.x.x  
Press Ctrl-P for previous command, Ctrl-N for next command, ? for help.
```

Login:

If at any prompt or partial command you press “?”, a list of options displays:

```
GIGAswitch Ethernet> ?  
  
community  SNMP Community configuration  
console    Console configuration  
download   TFTP code image download  
event      Event Table display  
exit       Exit the application  
feprom     Flash EPROM configuration  
module     Module configuration  
net        Network configuration  
pause      Pause for a given number of milliseconds  
ping       Ping protocol (ping <host> <tries> <delay>)  
port       Port configuration  
reset      Reset System  
rtc        Real Time Clock configuration  
setup      Setup console IP Address/Mask/Gateway  
stack      Last saved context display  
telnet     Telnet protocol (telnet <host>)  
user       User Account configuration  
verbose    Toggle verbose mode  
vlan       VLAN configuration
```

Basic Keyboard Commands

Keys	Action
#	Start of comment.
?	Display command help.
Ctrl-H	Backspace.
Ctrl-U	Erase line.

Command Line History

The system memorizes the last 20 commands typed. The following is the complete available list:

Table B-1: Command Line History Commands

Keys	Function
Ctrl-P	Previous command.
Ctrl-N	Next command.
Ctrl-L	Clear screen and redisplay current command.
Ctrl-Y	Display last command executed.

Scripts

Because the system accepts a complete command line, scripts can be written to automate procedures. Terminal emulators, such as HyperTerminal, allow the contents of a file to be read and input to the command line interpreter.

Help

Help is available in all menu levels. To get help for “net”, type in “net” followed by the Enter key (or type in “net ?”). Also, in verbose mode, typing in “net” followed by a space character will also display the help.

Community

Purpose

Allows you to set up community strings to provide levels of access for SNMP management programs, including the GIGAswitch/Ethernet Manager.

Syntax

```
community      set      access      1=none 2=readonly 3=readwrite
                addrType  1=any 2=ip
                comString string name
                currentIndex index number
                ipAddress  address
                securityLevel 1=normal 2=admin
                status      1=active 2=not in service 3=destroy
                trapReceiver 0=not a trap receiver 1=trap receiver
                get      all
                currentIndex
```

Parameters

access	Sets the access level for SNMP managers accessing the switch using the currentIndex string. 1 (<i>none</i>) makes the community string inactive. 2 (read only) allows the manager to perform get operations. 3 (read write) allows the manager full access to SNMP functions.
addrType	1 (any) causes the switch to authenticate the currentIndex string based on community string name only. 2 (ip) causes the switch to authenticate based on both community string and IP address.
comString	Adds a new community string to the table using the name you enter, and assigns this address the next available index number.
currentIndex	Selects which string you are working on currently. For example, if you set the current index to 2, and subsequent sets will be performed on the community string with index number 2.

Community

ipAddress	Assigns a specific IP address to the currentIndex string. If address type is set to 1 (any), the switch uses this address to authenticate SNMP requests. If trapReceiver is set to 1 (true), traps are sent to the host with this IP address.
securityLevel	1 (normal) provides normal set and get configuration operations. 2 (admin) provides access to configuring community strings, passwords, and other administrative functions.
trapReceiver	0 (false) means that traps are not sent to the host associated with the currentIndex community. 1 (true) means that traps are sent.
get all	Displays a list of all community strings and settings.
get currentIndex	Displays settings for the currentIndex community string. Use the community set currentIndex command to change the currentIndex string.

Example

The set of commands below does the following:

- 1 Creates a new community string called private.
- 2 Shows the list of currently configured community strings.
- 3 Changes the currentIndex so that subsequent commands affect the newly added string.
- 4 Sets the IP address associated with the string to 146.115.0.0.

```
(1)GIGAswitch Ethernet> com set comString private
```

```
(2)GIGAswitch Ethernet> com get all
```

```
Index String          IP Address          Access Security Traps Status
-----
1    public            ***.***.***.***    RW    NORM    F    A
2    private            ***.***.***.***    NONE  NORM    F    NR
```

```
(3)GIGAswitch Ethernet> com set currentIndex 2
```

```
(4)GIGAswitch Ethernet> com set ipAddress 146.115.0.0
```

```
GIGAswitch Ethernet> com get all
```

```
Index String          IP Address          Access Security Traps Status
-----
1    public            ***.***.***.***    RW    NORM    F    A
2    private            146.115.0.0        NONE  NORM    F    NR
```

Console

Purpose

Allows you to set communications parameters for the serial port on the front panel of the switch control processor.

Syntax

```
console    baudrate    rate
           databit    7, 8
           flowctrl    none, hardware, xon/xoff
           parity      none, even, odd
           stopbits    1, 2
           type        tty, ppp
           display
```

Parameters

baudrate	Enter the baud rate of the attached terminal. The default is 9,600.
databit	Number of data bits in each byte. The default is 8.
flowctrl	None, hardware, or xon/xoff. xon/xoff is the default.
parity	Odd, even, or none. None is the default.
stop bits	Number of stop bits in each byte. The default is 1.
type	Must be set to TTY. PPP not yet supported.
display	Displays the current console settings.

Example

The following command sets the terminal baud rate to 115, 200 baud:

```
GIGAswitch Ethernet> console baud 115200
```

Please change your console terminal to new baudrate

Download

Purpose

Allows you to download new code to the switch using TFTP. This command requires that the TFTP server location and TFTP file name have already been set using the web agent.

Syntax

```
download area tftp_server filename
```

Parameters

<i>area</i>	Area of memory that you want to download to. You must select APP2 with currently available versions of switch operational code.
<i>tftp_server</i>	The IP address of your TFTP server.
<i>filename</i>	The path and file name of the file you are downloading.

Example

```
GIGAswitch Ethernet> download app2 146.0.227.125 \tftpboot\file.bin
```

Event

Purpose

Allows you to view switch-based event and alarm logs.

Syntax

```
event      alarm
           clear log
           log
           shutdown_log
           table
```

Parameters

alarm	Displays the table of currently active alarms. This table is a good indicator of the current system health.
clear log	Clears all events in the event log.
log	Displays the event log.
shutdown_log	Displays the shutdown log, which a subset of the event logged, stored in NVRAM. This log is preserved during a switch shutdown, and may contain information about the cause of a switch failure.
table	Displays a list of events created in the system, and what action will be taken when these events occur.

Example

The following command displays the switch event log:

```
GIGAswitch Ethernet> event log

Log ID   Event ID Time Stamp           Severity   Value
-----
      1         1  97-Aug-27 17:57:25 Informative(20)
====> System started at 97-Aug-27 17:57:25
      2         5  97-Aug-27 17:57:29 Informative(20) 0
====> New Resource: Module 1. [Module 1]
      3         5  97-Aug-27 17:57:41 Informative(20) 0
====> New Resource: Module 6. [Module 6]
```

Exit

Purpose

Exits the system.

Syntax

exit

Parameters

None.

Example

```
GIGAswitch Ethernet> exit
```

```
Login:
```

Feprom

Purpose

Establishes what code area the switch will run operational code from after the next reboot.

Syntax

```
feprom    set    area
          get
```

Parameters

<i>area</i>	Must be APP2 unless otherwise instructed by your DIGITAL service representative.
get	Display information on current feprom settings.

Example

```
GIGAswitch Ethernet> feprom set APP2
Boot Flag set to app2.
GIGAswitch Ethernet> feprom get
Checking for valid image in BOOT.
File Information:
  File Format Type = Binary
  Target Location = Boot
  Data Compression = None
Product Information:
  Version Number = b1.00.1
  Serial Number = 000-00-0000
  Model Number = M5500-SUP-4
Image Information:
  Entry Address = 0x00020000
  Non-compressed Image:
    Size = 0x00054e0c bytes
    Checksum = 0xcalb
Checksum of image in FEPR0M is 0xcalb.
Checksum of image in DRAM is 0xcd8d.
-----
.
.
.
Upon reset, image stored as APP2 will execute.
```

Module

Purpose

Allows you to display basic information about modules in the switch.

Syntax

```
module    get    all
           module slot
```

Parameters

all	Shows information on all modules in the switch.
module	Lets you view information about a particular slot by entering the slot number.

Example

The following command displays information on all modules in the switch:

```
GIGAswitch Ethernet> module get all

      Module Configuration
Module  Model Number  Description          Ports  Name
-----  -
1       DGBGI-AA           SCP                  1      Module 1
Module  Model Number  Description          Ports  Name
-----  -
6       DGBGT-AA           20 Port 10/100 Mb   20     Module 6
```

Net

Purpose

Allows you to configure information that allows you to communicate with the switch management agent using the Internet Protocol Suite. This allows you to connect to the switch inband over the network, or using IP over the switch control processor Ethernet and serial console ports.

Syntax

```

net    ip    address    delete address
                                ethernet_console <address> <mask>
                                inband <address> <mask>
                                default_gateway ethernet_console <address>
                                inband <address>
                                display    arp_cache
                                interfaces
                                route_table

```

Parameters

delete	Deletes the indicated address.
address	Assigns an IP address to the indicated interface.
ethernet_console	Switch control processor front panel 10BASE-T interface.
inband	Switch control processor inband connection.
default_gateway	Sets the location (IP address) of the router port for the subnetwork that interface resides on.
<i>address</i>	IP address, expressed on decimal dot notation (nnn.nnn.nnn.nnn).
<i>mask</i>	Subnetwork mask for the subnetwork. The subnetwork mask separates the network address from the host addresses. For example, the subnetwork mask 255.255.255.0 means that the first three numbers in an IP address are common for all hosts on this subnet.

display	arp_cache: Displays the current ARP (Address Resolution Protocol) table entries for this host. This information can be useful for resolving connectivity problems because it identifies IP addresses that this host has “seen.” interfaces: Lists identification for the interfaces on the switch control processor. route_table: Displays the route_table for the switch control processor.
---------	--

Example

The following command sets an IP address and subnet mask for the switch’s inband connections:

```
GIGAswitch Ethernet> net ip address inband 127.115.106.254 255.255.255.0
```

NVRAM

NVRAM

Purpose

Use this command to erase all configuration information saved in the switch, restoring factory defaults.

CAUTION

This action deletes all configured settings and replaces them with factory default values. All configuration settings will be lost.

Syntax

`nvrn initialize`

Parameters

None.

Example

```
GIGAswitch Ethernet> nvrn initialize
```

Pause

Purpose

Pauses execution of operational code. Use this command to halt script execution.

Syntax

```
pause      time
```

Parameters

time Length of pause in milliseconds.

Example

```
GIGAswitch Ethernet> pause 1200
```

Ping

Purpose

Allows you to determine if a host is reachable inband from the switch control processor.

Syntax

```
ping host tries delay
```

Parameters

<i>host</i>	The host name or IP address of the host you are testing connectivity with.
<i>tries</i>	The number of ping attempts you want to perform with this operation. The default is 5.
<i>delay</i>	The number of milliseconds the switch waits between generating pings. The default is 1000.

Example

The following command tests connectivity with a host named “jefferson”:

```
GIGAswitch Ethernet> ping 146.115.106.5
[host 146.115.106.5, max tries 5, delay 1.000]
#1 ok, RTT 0.010 seconds
#2 ok, RTT 0.000 seconds
#3 ok, RTT 0.010 seconds
#4 ok, RTT 0.000 seconds
#5 ok, RTT 0.000 seconds
[finished]
```

Port

Purpose

Allows you to enable or disable switch I/O module ports, and to view basic information pertaining to switch ports.

Syntax

```
port set mode slot port enable or disable
      get module slot
           port slot port
           all
```

Parameters

mode	Sets the mode of the selected port to either enable or disable.
<i>slot</i>	Switch slot you are specifying for this command.
<i>port</i>	The port number the command applies to.
module	Gets port information for the module slot you select.
port	Gets port information for the port you select.
all	Gets port information for all ports in the system.

Example

The following command displays port information for the first port in the sixth slot on the switch:

```
GIGAswitch Ethernet> port get port 6 1
      Port Configuration for module 6
Port   Type                Connector   Mode     Status
----   ----                -
1      10/100 Mb Ethernet    rj45      Enable   Link Failure
```

Reset

Reset

Purpose

Allows you to perform a warm reboot of the switch system.

Syntax

reset

Parameters

None.

Example

```
GIGAswitch Ethernet> reset
```

Rtc

Purpose

Allows you to set the current date and time on the switch clock.

Syntax

```
rtc    get
       set    date    mm/dd/yyyy
           time    hh:mm:ss
```

Parameters

date	Use to set the date in the mm/dd/yyyy format.
time	Use to set the time in hh:mm:ss format.

Example

Use the following command to set the system date to August 28, 1997.

```
GIGAswitch Ethernet> rtc set date 08/28/1997
```

```
The date is currently set to 07/14/1997.
```

```
Date has been set to 08/28/1997
```

Setup

Purpose

Provides a quick way to set up IP connectivity to the switch.

Syntax

setup

Parameters

None.

Example

```
GIGAswitch Ethernet> setup
```

```
Welcome to Switch Setup. The brief series of questions that follows will help you to configure this switch. After completing this process, you will be able to manage the switch using:
```

- the switch-based HTTP server
- the Element Management System.

```
Text in [] is the default answer for each questions. To accept the default, press ENTER.
```

```
Would you like to change the super user password [Yes]? y
```

```
Old Password:
```

```
New Password:
```

```
Re-type New Password:
```

```
User Password Changed Successfully.
```

```
What do you want the switch manager's console
```

```
Ethernet IP Address to be (ex. 255.111.222.333)? 146.115.106.182
```

```
What is the subnet mask for your network's
```

```
IP address (ex 255.255.0.0)? 255.255.255.0
```

```
IP Address configuration succeeded.
```

```
What is the IP address of the default gateway
```

```
port for this network segment (ex. 255.111.222.333)? 146.115.106.129
```

```
Default Gateway configuration succeeded.
```

```
You can now connect to the switch using the front-panel out-of-band 10BASE-T connection. This allows you to log in using the embedded web agent.
```

```
See the Installation and Operation Guide for instructions on establishing an inband connection over the network.
```

Stack

Purpose

Displays the contents of the stack when debugging problems with the DIGITAL technical support staff.

Syntax

stack

Parameters

None.

Example

The following command performs a stack dump of the system memory:

```
GIGAswitch Ethernet> stack
```

```
General Registers:
```

```
r0: 0x00000000  r1: 0x00000000  r2: 0x00000000  r3: 0x00000000
r4: 0x00000000  r5: 0x00000000  r6: 0x00000000  r7: 0x00000000
r8: 0x00000000  r9: 0x00000000  r10: 0x00000000  r11: 0x00000000
r12: 0x00000000  r13: 0x00000000  r14: 0x00000000  r15: 0x00000000
r16: 0x00000000  r17: 0x00000000  r18: 0x00000000  r19: 0x00000000
r20: 0x00000000  r21: 0x00000000  r22: 0x00000000  r23: 0x00000000
r24: 0x00000000  r25: 0x00000000  r26: 0x00000000  r27: 0x00000000
r28: 0x00000000  r29: 0x00000000  r30: 0x00000000  r31: 0x00000000
```

```
Begin Stack Trace
```

```
0x00000000
0x00000000
0x00000000
0x00000000
0x00000000
```

```
.
.
.
```

```
0x00000000
0x00000000
0x00000000
0x00000000
0x00000000
0x00000000
```

```
Complete Stack Trace NOT SAVED
```

Telnet

Purpose

Allows you to use the Telnet protocol to connect from the switch to other Telnet-capable hosts.

Syntax

`telnet host`

Parameters

<i>host</i>	The IP address of the Telnet-capable host you are connecting to.
-------------	--

Example

The following command establishes a connection to another switch:

```
GIGAswitch Ethernet> telnet 146.115.106.231
translating 146.115.106.231...ok
connecting to host 146.115.106.231 (146.115.106.231)...open
Escape character is '^]'

Digital Equipment Corporation GIGAswitch/Ethernet Agent v1.x.x
Press Ctrl-P for previous command, Ctrl-N for next command, ? for help.
Login:
```

User

Purpose

Allows you to set up and administer switch user names and passwords. These passwords are used by the web server interface as well.

Syntax

```

user    list
        changePassword    old_password new_password
        delete            user_id
        add                name password access_level

```

Parameters

<code>list</code>	Lists all currently implemented user names.
<code>changePassword</code>	Changes the password of the current user.
<code>delete</code>	Deletes the indicated user.
<i>user_id</i>	Identification number of a user in the user list. Use the user list command to see a list of currently-created users.
<code>add</code>	Adds a new user to the user list.
<i>name</i>	Login name for the new user.
<i>password</i>	Password for the new user.
<i>access_level</i>	Access-level for the new user. See the following table for access provided by each level.

User

Access Level	Can	Cannot
1 (READ_ONLY)	View switch configuration settings and statistics.	View user accounts and community strings. Change switch configurations.
2 (READ_WRITE)	View <i>and set</i> switch configuration settings, and view statistics.	View user accounts and community strings.
3 (ADMINISTRATOR)	View and set all switch parameters.	N/A

Example

The following command creates a user called jenny with a password system and an access level of administrator:

```
GIGAswitch Ethernet> user add jenny system 3
```

Verbose

Purpose

Allows you to toggle between a mode where the space bar displays options automatically (verbose on), and a mode where the interface requires the ? key before providing help.

Syntax

```
verbose    on
           off
```

Parameters

on	Available options display each time you press the space bar.
off	Help displays only when you press "?".

Example

```
GIGAswitch Ethernet> verbose on
```

VLAN

VLAN

Purpose

Allows you to create VLAN names and ID numbers, delete VLANs, display VLAN configurations.

Syntax

```
vlan      display      vlan      vlan_id
                               setIEEEProtocolType
                               create/delete  vlan      vlan_id vlan_name
                               vport         vlan_id fabricPortID subPortID
```

Parameters

display	Displays the selected VLAN, and IEEE Protocol identifier.
create	Create the specified VLAN, or VLAN assignment.
delete	Delete the specified VLAN, or VLAN assignment.
vlan <i>vlan_id</i>	Perform the action on the specified VLAN, identified by its ID number.
setIEEEProtocolType	Allows you to set a value that identifies VLANs created using IEEE 802.1Q vlan tagging. This number is settable so that it can be reset if the IEEE changes the ID code.

Example

```
GIGAswitch Ethernet> vlan display vlan 1
```

```
VLAN name: Default      VLAN ID: 1      Group ID: 2      AFT Index: 2
Switch ports: 1.1 2.1 3.1 4.1 5.1 6.1 7.1 8.1 8.2 8.3 8.4 8.5 8.6 8.7
9.3 9.4 9.5 9.6 9.7 9.8 9.9 9.10 10.1 10.2 10.3 10.4 10.5 10.6 10.7
10.9 10.10 11.1 11.2 11.3 11.4 11.5 11.6 11.7 11.8 11.9 12.2 12.3
12.4 12.5 12.6 12.7 12.8 12.9 12.10 13.1 13.2 13.3 13.4 13.5 13.8
```

Appendix C

Product Specifications

Overview

Introduction

This appendix lists the specifications for the GIGAswitch/Ethernet system.

In This Appendix

This appendix contains the following topics:

Topic	Page
Product Specifications	C-2
Acoustical Specifications	C-4

Product Specifications

[Table C-1](#) lists the product specifications for the system.

Table C-1: Product Specifications

Parameter	Specification
Environment	
Operating temperature ¹	0°C to 40°C (32°F to 104°F)
Storage temperature	-20°C to 80° C (4°F to 176°F)
Relative humidity	5% to 95% noncondensing
Power	550 W maximum, 130 W minimum, 400–450 W typical
AC input voltage	100–120/200–240 V ac @ +6%, -10%
Frequency	50 Hz to 60 Hz
Maximum power consumption	8.0 A @ 120 V 4.0 A @ 240 V
Physical	
Height	26.67 cm (10.5 in)
Width	44.45 cm (17.5 in)
Depth	45.72 cm (18 in)
Weight	30 kg (65 lb), fully loaded
Shock (Class A/B for products weighing under 100 lb)	10 G / 10 ms half sine pulse in three orthogonal axes
Vibration (Class C)	5 to 2000 Hz sine sweep @ 0.50 G limited by 0.5mm (0.02 in) displacement DA* 200 to 500 Hz sine sweep @ 0.10 G

¹ For sites above 2400 m (8,000 ft), decrease the operating temperature specification by 1.8°C for each 1000 m or 3.2°F for each 3200 ft.

Parameter	Specification
Certification	BCIQ CE, Class A CISPR 22, Class A CSA 22.2-No. 950 C-TICK EN55022, Class A EN60950 FCC Part 15, Class A IEC 950 TÜV GS UL 1950, VCCI, Class A
Standards	IEEE 802.1D - Bridging Standard IEEE 802.1p - Multicast & Class of Service (Draft Standard) IEEE 802.1Q - Virtual LANs (Draft Standard) IEEE 802.2 - LLC IEEE 802.3 - Ethernet IEEE 802.3u - Fast Ethernet, IEEE 802.3x - Flow control IEEE 802.3z - Gigabit Ethernet (Draft Standard) RFC 768 UDP - User Datagram Protocol RFC 783 TFTP - Trivial File Transfer Protocol RFC 791 IPv4 - Internet Protocol version 4 RFC 792 ICMP - Internet Control Message Protocol RFC 793 TCP - Transmission Control Protocol RFC 854 Telnet RFC 1157 SNMP v1 - Simple Network Management Protocol version 1 RFC 1213 MIB-II RFC 1643 Ethernet MIB RFC 1757 RMON Groups: etherStats, history, events, alarms RFC 1866 HTML - Hypertext Markup Language version 2 RFC 2068 HTTP - Hypertext Transfer Protocol Year 2000

Acoustical Specifications

Table C-2 and Table C-3 list the acoustical specifications for the system in English and German.

Table C-2: English Acoustical Specifications

Declared Values per ISO 9296 and ISO 7779¹

Product	Sound Power Level $L_{WA,d}$, B	Sound Pressure Level L_{pAm} , dBA (bystander positions)
	Idle/Operate	Idle/Operate
DGBGA-AA	6.6	51
DGBGA-AA + 2XDGBGP-AA	6.7	52

¹ Current values for specific configurations are available from Digital Equipment Corporation representatives. 1 B = 10 dBA.

Table C-3: German Acoustical Specifications

Schallemissionswerte Werteangaben nach ISO 9296 und ISO 7779/DIN EN27779²

Produkt	Schalleistungspegel $L_{WA,d}$, B	Schalldruckpegel L_{pAm} , dBA (Zuschauerpositionen)
	Leerlauf/Betrieb	Leerlauf/Betrieb
DGBGA-AA	6,6	51
DGBGA-AA + 2XDGBGP-AA	6,7	52

² Aktuelle Werte für spezielle Ausrüstungsstufen sind über die Digital Equipment Vertretungen erhältlich. 1 B = 10 dBA.

Index

Symbols

"diag" user 3-10
"manuf" user 3-10
"root" user 3-10

Numbers

10BASE-T Crossover Patch Cables 1-2, 3-5
2+1 Power 2-13
802.1d Spanning Tree 4-5

A

AC power source 1-4
Active Alarms 7-5
Active Backpressure 3-15
Address Age Time 6-2
Address Forwarding Table 6-1
 Capacity 6-5
Address Table Sizing 6-2
ADMINISTRATOR User 3-11
AFT Table Configuration 6-2
Age Timer 5-6
Ageout 6-9
Aggregating bandwidth 4-13
Air Flow Requirements 1-4
All Module Ports Configuration 3-18
Auto Increment HT Size 4-4
Auto Increment Table Size 6-4
Automatic VLAN Creation 3-22
Auto-negotiating Speed/Duplexity
 Advertisement 3-15
Auto-negotiation Mode 3-15, 3-18

B

Baud Rate 3-25
Blocking State (Spanning Tree) 4-11
Broadcast Domains 4-2
Broadcast Packets 8-7
Buffer Management 2-13
 Fast Ethernet Buffers 5-7
Bytes 8-6

C

Cable Distances, recommended 1-12
Cables 1-10
Capacity, switch 2-7
Category 5 Cables 1-10
Class of Service 2-14
Clear Counters 8-3
Collisions 8-9
Command Line History Commands B-5
Command Line Interface B-1
 Community Command B-6
 Console Command B-8
 Download Command B-9
 Event Command B-10
 Exit Command B-11
 Feprom Command B-12
 Module Command B-13
 Net Command B-14
 NVRAM Command B-16
 Pause Command B-17
 Ping Command B-18
 Port Command B-19
 Reset Command B-20
 Rtc Command B-21
 Setup Command B-22
 Stack Command B-23
 Telnet Command B-24
 User Command B-25
 Verbose Command B-27
 VLAN Command B-28
Community Command B-6
Components 1-2
Congestion Drops 5-7
Connecting to Switch 3-4
Console Command B-8
Console Serial Port 3-25
Copper Cable Lengths 1-12
CRC Alignment Errors 8-8
Crossbar 2-6
Crossover Cables 1-10

D

- Date, setting 3-8
- Default Password 3-4
- Device Contact, setting 3-8
- Device Location, setting 3-8
- Down State (Spanning Tree) 4-11
- Download Command B-9
- Download Procedure A-3
- Download Status A-5
- Drop Events 8-6

E

- Ejectors 1-10
- Electrostatic Discharge (ESD) 1-5
- Enable Ports 3-14
- Entry Configuration 6-8
- Entry Search 6-5
- Ethernet Interface Statistics 8-4
- Event Classes 7-7
- Event Command B-10
- Event Configuration 7-6
- Event Log 7-7
- Exit Command B-11

F

- Fabric Ports 2-7
- Fast Ethernet Buffers 5-7
- Fast Ethernet Modules 2-5
- Fast Start Mode 4-9
- Fault Tolerance 2-13
- Female DTE-to-RJ-45 connector 1-2
- Feprom Command B-12
- FEPRM Contents A-3
- FEPRM Target Section A-4
- Fiber Link Distances 1-12
- Flood Port 4-15
- Flow Control 3-17
- Flow Control (serial port) 3-25
- Flow Control Mode 3-14 to 3-15
- Forwarding State (Spanning Tree) 4-11
- Fragments 8-9
- Frame Classification 2-8
- Frame VLAN Tags 3-21

G

- General window 3-8
- Gigabit-Speed Modules 2-5
- Ground, electrical 1-5

H

- Hardware Overview 2-3
- Hash Table Size 4-4
- Help, online 3-26
- High and Normal Overflow Drops 5-7
- High Priority Allocation 5-6
- High Priority Service Ratio 5-6
- High Shutdown Temperature 7-4
- High-priority Traffic 5-3
- Hot-swappable Components 2-13
- HTML 2-14
- Hunt Groups 2-10, 4-13
 - Adding ports 4-15
 - Before configuring 4-13
 - Flood port 4-15
 - Why to use 4-13

I

- IEEE 802.1d Spanning Tree 2-12
- IEEE 802.3X PAUSE 5-3
- Inband Access to Switch 3-4
- Installation 1-1
 - location 1-4
- Instance IDs 6-4

J

- Jabbers 8-9

K

- Known Mode 3-22

L

- Learning State (Spanning Tree) 4-11
- LEDs 1-15, 7-2
- Listening State (Spanning Tree) 4-11
- Log Size, setting 7-6
- Logging In 3-7

Low Shutdown Temperature 7-4
Lower Warning Temperature 7-4

M

MAC Address 2-7, 6-6
Male DCE-to-RJ-45 connector 1-2
Male DTE-to-RJ-45 null modem connector 1-2
Mirror Port 8-11 to 8-12
Module Command B-13
Module Status LED 1-15
Modules
 ejectors 1-10
 installing 1-9
 types 2-4
Modules & Ports 3-13
Multicast Packets 8-7
Multi-gigabit Connections 4-13
Multilayer Spanning Tree 4-5

N

Net Command B-14
Normal-priority Traffic 5-3
NVRAM Command B-16

O

Online Help 3-26
Out-of-Band Connection Kit 1-2
Overflow Drops 5-7

P

Packed Frame Buffers 2-13
Packet Distribution Statistics 8-10
Packets 8-6
Path Cost 4-12
Pause Command B-17
Persistence 6-7
Ping Command B-18
Pinouts 1-11
Port Command B-19
Port Density 2-3
Port Duplex Mode 3-15
Port LED 1-15
Port Name 3-15

Ports

 Configuring 3-12
 Enabling 3-14
Power Consumption 1-13
Power Management 1-13
Power On Behavior 1-14
Power Supplies
 connecting 1-14
Priority 6-7
Priority Threshold 5-6

Q

Queues 5-2
 Service ratio 5-3

R

Rack Mount 1-6
Rack Mount Flanges 1-6
Rate Limit Burst size 3-18
Rate Limit Mode 3-16, 3-18
READ_ONLY User 3-11
READ_WRITE User 3-11
Redundant Switch Links 2-13
Relative humidity 1-4
Reset Command B-20
RMON 2-14
RMON History Samples 8-5
Rtc Command B-21
Rubber Feet 1-8
RX LED 1-15

S

Sampler Type 8-12
Sampling Interval 8-12
SC-type Connectors 1-10
Serial Line Connection 3-2
Server Location 3-27
Service Ratio (queues) 2-14, 5-3
Setup Command B-22
Shutdown Log 7-7
SNMP 2-14
 Administration 3-23
 Communities 3-23

- Security Levels 3-24
- Spanning Tree 2-12
 - Bridge Forward Delay 4-8
 - Bridge Hello Time 4-8
 - Bridge Max Age 4-8
 - Forward Delay 4-8
 - Hello Time 4-8
 - Max Age 4-8
 - Mode 4-8
 - Path Cost 4-12
 - Priority 4-8
 - Why to use 4-5
- Spanning Tree Bridge Ports 4-10
- Spanning Tree Fast Start Mode 4-9
- Spanning Tree per VLAN 2-12, 4-5
- Spanning Tree Ports
 - Designated Bridge 4-11
 - Designated Cost 4-11
 - Designated Port 4-11
 - Designated Root 4-11
 - Forward Transitions 4-11
 - State 4-11
- Speed Mode 3-15
- Stack Command B-23
- Stale Drops 5-7
- Static Address Configuration 6-8
- Statistics 8-2
- Straight-through RJ-45 Cable 1-2
- Super Age Time 6-2
- Supported Browsers 3-7
- Switch Control Processor 2-14
- Switch Description 2-2
- Switch Name, setting 3-8
- Switch Ports Parameters 3-19
- System Events 7-6

T

- Table Top Installation 1-8
- Telnet Command B-24
- Temperature 1-4
- Temperature Status 7-3
- Temperature Thresholds 7-4
- Terminal Setup 3-2
- TFTP Download A-4

- TFTP Server IP Address A-4
- Throughput 2-7
- Time, Setting 3-8
- Total Bucket Utilization 6-4
- Traffic Mirror Port 8-12
- Trunk Mode 3-20
- TX LED 1-15

U

- Undersize and Oversize Packets 8-8
- Unpacking 1-1
- Upper Warning Temperature 7-4
- User Accounts 3-10
 - Access Levels 3-11
- User Command B-25
- User Logins 3-10

V

- Verbose Command B-27
- Virtual LANs 2-8
 - Assignment 3-20
 - Binding Options 3-21
 - Creating 4-3
 - Parameters 4-4
 - Why to use 4-2
- VLAN Command B-28

W

- Web Agent 2-14
 - connecting to 3-3
- Web-based Management 2-14
- Weight xviii, 1-6

X

- Xon/Xoff 3-25