



# PCXAV-Tx Auto-Scanning Color Monitor

---

## Installation Guide

Order Number: ER-XAVTX-IM. A01

**Digital Equipment Corporation**

**August 1997**

---

The information in this document is subject to change without notice and should not be construed as a commitment by Digital Equipment Corporation.

Restricted Rights: Use, duplication, or disclosure by the U.S. Government is subject to restrictions as set forth in subparagraph (c) (1) (ii) of the Rights in Technical Data and Computer Software clause at DFARS 252.227-7013.

**Note:** This equipment has been tested and found to comply with the limits for a Class B digital device, pursuant to Part 15 of the FCC rules. These limits are designed to provide reasonable protection against harmful interference in a residential installation. Any changes or modification made to this equipment may void the user's authority to operate this equipment.

This equipment generates, uses, and can radiate radio frequency energy and, if not installed and used in accordance with the instructions, may cause harmful interference to radio and television reception; however, there is no guarantee that interference will not occur in a particular installation. If this equipment does cause harmful interference to radio or television reception, which can be determined by turning the equipment off and on, the user is encouraged to try to correct the interference by one of the following measures:

- Re-orient or relocate the receiving antenna.
- Increase the separation between the equipment and the receiver.
- Connect the equipment to an outlet on a circuit different from that to which the receiver is connected.
- Consult the dealer or an experienced radio/TV technician for help.

DO NOT attempt to modify this equipment. If modified, the FCC may void your authority to operate this equipment.

#### **Canadian Department of Communications Statement**

This Class B digital apparatus meets all requirements of the Canadian Interference Causing Equipment Regulations.

#### **VCCI Class 2 - Japan**

DEC and the DIGITAL logo are trademarks of Digital Equipment Corporation. IBM is a registered trademark of International Business Machines Corporation. VESA is a registered trademark of the Video Electronics Standards Association. All other trademarks and registered trademarks are the property of their respective holders.

As an ENERGY STAR™ partner, Digital Equipment Corporation has determined that this product meets the ENERGY STAR™ guidelines for energy efficiency.

© 1997 Digital Equipment Corporation.  
All Rights Reserved.

# Contents

<b>Introduction</b> .....	<b>1</b>
Overview .....	1
DDC (Display Data Channel) .....	2
<b>Installation</b> .....	<b>2</b>
Installation/Operating Guidelines .....	2
Monitor Installation .....	3
On-Screen Display Controls .....	5
Color Selection .....	7
Option Select.....	9
<b>Display Modes</b> .....	<b>10</b>
Preset Modes .....	10
User Modes .....	11
Recalling Display Modes .....	11
<b>Servicing</b> .....	<b>12</b>
Cleaning the Monitor .....	12
Maintenance and Troubleshooting.....	12
<b>Specifications</b> .....	<b>14</b>
Monitor Specifications .....	14
Power Management System.....	15
Environment, Health and Safety .....	15
<b>Environmental Labelling of Personal Computers</b> .....	<b>17</b>
TCO'95 Environmental Requirements .....	18
Shipping Package.....	20
Monitor Registration .....	21

## Figures

Figure 1. PCXAV-Tx Monitor .....	1
Figure 2. PCXAV-Tx Monitor (Rear View).....	3
Figure 3. Monitor Controls, LED, and Power Switch .....	4

Figure 4. Brightness Adjustment Display .....5  
 Figure 5. On-Screen Adjustment Display.....5  
 Figure 6. Color Selection .....7  
 Figure 7. Color Adjustments .....8  
 Figure 8. Option Select On-Screen Display .....9

**Tables**



Table 1. Monitor Controls and Functions .....4  
 Table 2. On-Screen Display Icons .....6  
 Table 3. Option Select Icons.....9  
 Table 4. Display Modes and Addressability ..... 10  
 Table 5. Identifying and Correcting Problems ..... 13  
 Table 6. Monitor Specifications..... 14  
 Table 7. Power Saving States ..... 15

**Audience**

This guide is intended for user’s who wish to install the monitor.

**Conventions**

The following conventions are used in this document:

	<b>NOTE:</b> Provides general information.
	<b>CAUTION:</b> Provides information to prevent damage to equipment.
	<b>WARNING:</b> Indicates the presence of a hazard that can cause personal injury if the hazard is not avoided.

## Introduction

### Overview

The PCXAV-Tx monitor is an auto-scanning color monitor with high resolution. This monitor offers the following features:

- Up to 36 display modes, 12 of which are preset, including VESA 85, 1024 x 768, 1280 x 1024, and 1600 x 1200 non-interlaced resolution.
- 85 Hz refresh with 640 x 480, 1024 x 768, and 1280 x 1024 modes
- Power Management system that exceeds EPA ENERGY STAR™ requirements for saving energy.
- VESA Data Display Channel - DDC1, DDC2B, and DDC2AB
- Complies with Swedish MPRII and TCO'95 standards for the environment, health and safety
- Anti-glare screen with anti-static coating

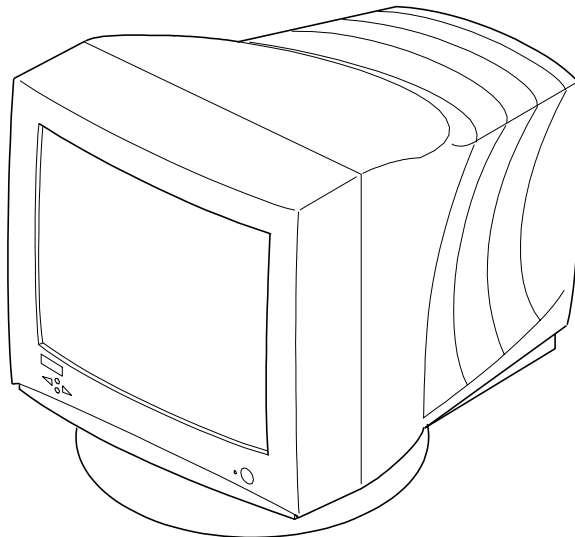

DEC01296

**Figure 1. PCXAV-Tx Monitor**

## DDC (Display Data Channel)

DDC is a communication channel over which the monitor automatically informs the host system about its capabilities. DDC1 and DDC2B carry out uni-directional communications between the PC and the monitor. The system will perform the “Plug and Play” feature if both the monitor and the host implement DDC protocol.

## Installation

### Installation/Operating Guidelines



**CAUTION:** Handle the CRT with Super-T coating with care. Keep hard objects such as pencils, game controls, buttons, tie pins, and belt buckles away from the monitor surface to avoid scratching the surface.

Observe the following basic rules for installation and use.

#### Do . . .

- Use the power cord supplied with the monitor, which is UL-, CSA-, and VDE-approved.
- Turn the monitor off when not being used for an extended period of time, or use Power Management if applicable.

#### Do Not . . .

- Overload the ac outlet.
- Move the monitor on a stand over carpet or thresholds.
- Push objects into the monitor’s openings.
- Add accessories that are not designed for this monitor.
- Operate the monitor near a radiator or heat source, or near water or in a damp environment, which could cause an electrical hazard.
- Operate the monitor near magnets, motor devices, transformers, high power lines, or large steel pillars, which can cause distortion in the picture.
- Obstruct the ventilation openings in the monitor’s cabinet, such as placing the monitor on a rug or within an enclosure.

## Monitor Installation

To install the monitor:

1. Make sure the power to the monitor and the computer is off.
2. Connect the monitor's signal cable (1) to the 15-pin interface connector on the High Resolution Graphic Video Adapter on the back of the computer.
3. Plug the ac power cord to the monitor (2), then to a properly-grounded ac electrical outlet.

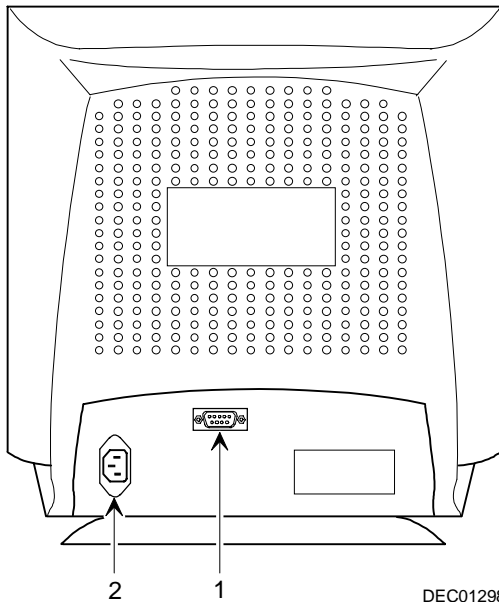

Figure 2. PCXAV-Tx Monitor (Rear View) DEC01298

### Turn On Power to Monitor

Figure 3 shows the monitor controls, which are described in Table 1. Push the power switch button (1) to turn on the monitor. The power indicator LED (2) to the left of the switch should light green.

### Contrast and Brightness Controls

The Contrast (3) and Brightness (4) controls are located under the front of the monitor. When either of these controls are moved, the display indicates the current setting with a shaded bar, such as shown in Figure 4.

The On-Screen Display (OSD) controls (5) are described in the next section.

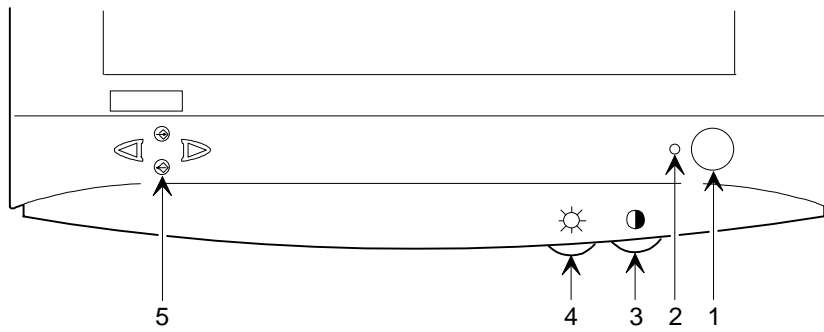

DEC01297

**Figure 3. Monitor Controls, LED, and Power Switch**

**Table 1. Monitor Controls and Functions**

	Icon	Control	Use to ...
1		Power switch	Turn on/off the monitor.
2		Power indicator LED	Indicate power on state: Green is full power on; amber is a power-saving state.
3		Contrast	Selects the contrast level of the screen display.
4		Brightness	Selects the brightness level of the screen display.
5		OSD Enter	Enter the On-Screen Display or select the OSD icon.
		OSD adjustment buttons	Move to the desired icon and increase or decrease the adjustment level of the selected item.
		OSD Exit	Exit the OSD menu.



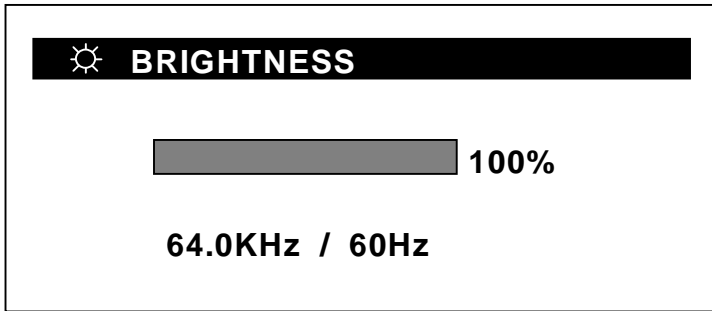







Figure 4. Brightness Adjustment Display

DEC01263

**On-Screen Display Controls**

When you press the  button twice on the monitor, the monitor adjustments icons are shown on the screen, Figure 5. When the screen outline is blue, use the  and  buttons to move from one icon to another to choose the desired icon. Table 2 lists the icons and their meaning.

When the desired icon is highlighted, press the  select button to display the adjustment screen. Then use the  and  buttons to make the necessary adjustment. Once you make an adjustment, the monitor automatically maintains it even when it is off.

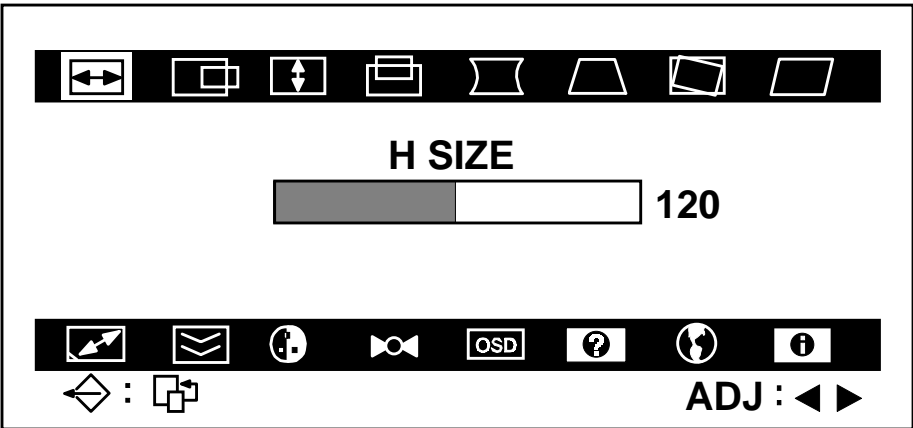

















Figure 5. On-Screen Adjustment Display

DEC01264-A

**Table 2. On-Screen Display Icons**

Icon	Name	Use
	Horizontal Size	Adjusts the image width.
	Horizontal Position	Adjusts the horizontal position.
	Vertical Size	Adjusts the image height.
	Vertical Position	Adjusts the vertical position.
	Side Pincushion	Corrects the bowing in and out.
	Trapezoid	Corrects the geometric distortion.
	Tilt	Tilts the entire screen image left or right.
	Parallelogram	Adjusts for skewing of the screen image by tilting the top of the screen image left or right.
	Zoom	Simultaneously adjusts horizontal and vertical image to make it smaller or larger.
	Moire Reduction	Allows you to reduce the moire, caused by interference of horizontal scan lines with the periodical dot on the screen. To adjust, select the ON position and push the ► button.
	Color Select	Selects the color temperature: 9300°K/6550°K/User.
	Mode Recall	Recalls all factory preset modes. If the monitor is operating in a user mode, this control has no effect.
	On Screen Display Adjust	Allows you to adjust the On Screen Display (OSD) position.
	Option Select	Gives you access to two options: manual degaussing and beep. See <b>Option Select</b> section.

	<b>Language Select</b>	Allows you to choose the language in which the control names are displayed: English, German, French, Spanish, or Italian.
	<b>Mode Information</b>	Provides operating information about the monitor. This icon displays three sequential on-screen displays. The first shows the total number of preset, user mode, and mode data information. The second shows the data for preset modes. And the third shows the user mode data. The ► key displays the next selection, and the ◀ key displays the previous selection.

## Color Selection

The color selection icon, at the bottom of the screen, displays two color temperature settings 9300°K and 6550°K, shown in Figure 6. These are the normal settings for optimum color. If you wish to change the individual colors, select the pixel squares icon and press the  control to display the color adjustments, shown in Figure 7.

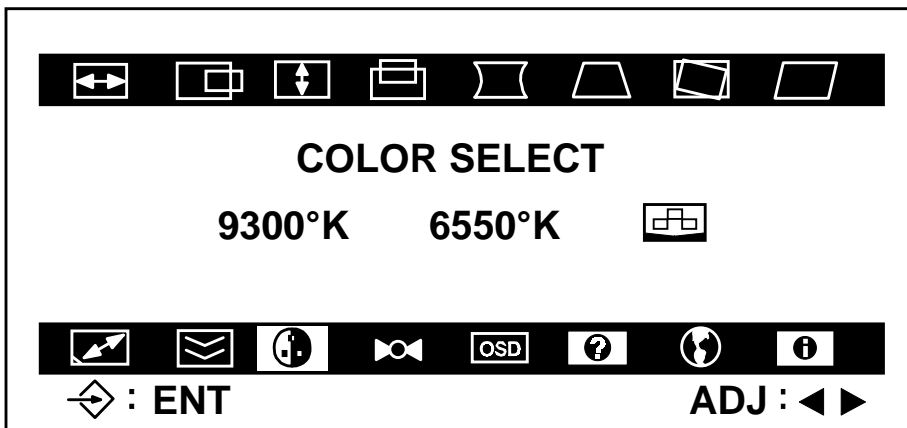









Figure 6. Color Selection

DEC01265

## Color Adjustments

Press the  control to move the  pointer to the Red or Blue bar. Then use the adjustment keys (   ) to adjust the gain (temperature) of the color. The  key increases the color in the image; the  key decreases the color in the image.

When the  pointer is on Color Recall, either adjustment key returns your screen to the preset color.

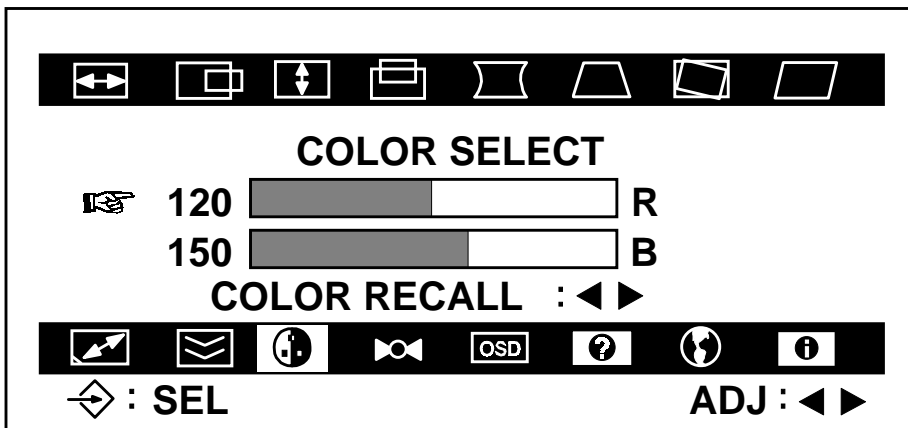





Figure 7. Color Adjustments

DEC01266

## Option Select

The option select icon, , gives you access to two options, shown in Figure 8. Table 3 lists these icons and their meaning.

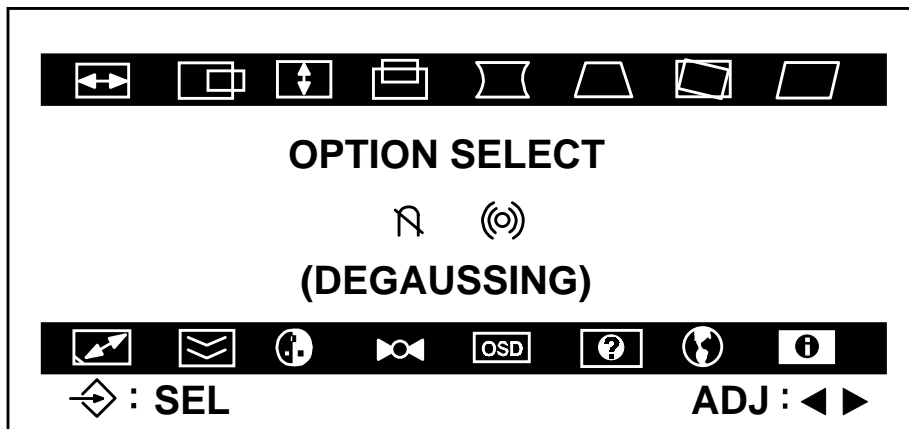

Press the  button to enter the submenu, then use the  and  buttons to make the necessary change.



DEC01267-A

Figure 8. Option Select On-Screen Display

Table 3. Option Select Icons

Icon	Name	Use
	Manual Degaussing	Manually degausses the CRT to eliminate any distortion caused by geographic location or magnetic interference.
	Beep On/Off	Turn the monitor beep signal on or off.

## Display Modes

### Preset Modes

The monitor has 36 memory locations for display modes, 12 of which are factory preset to popular video modes. The remaining 24 modes are left blank for user modes generated by your video card.

**Table 4. Display Modes and Addressability**

	Display Mode	Addressability	Horizontal Freq (kHz)	V Refresh (Hz)	H Sync	V Sync
1	VGA	640 x 480	31.46	59.94	-	-
2	VGA, VESA 85	640 x 480	43.27	85.00	-	-
3	DOS, 70	720 x 400	31.47	70.08	-	+
4	SVGA	800 x 600	37.88	60.32	+	+
5	SVGA, VESA 85	800 x 600	53.67	85.06	+	+
6	1024 x 768, 60	1024 x 768	48.36	60.00	-	-
7	1024 x 768, VESA 75	1024 x 768	60.02	75.03	+	+
8	1024 x 768, VESA 85	1024 x 768	68.68	85.00	+	+
9	1280 x 1024	1280 x 1024	63.98	60.02	+	+
10	1280 x 1024	1280 x 1024	91.15	85.02	+	+
11	1600 x 1200	1600 x 1200	81.25	65.00	+	+
12	1600 x 1200	1600 x 1200	93.75	75.00	+	+

If the monitor detects one of the frequencies from your video card or system, it sets that mode and any stored image adjustments you may have made.

You may need to change the image settings if you change display modes (for example, you go from a 640 x 480 display mode in DOS to a 800 x 600 display mode in Windows). Adjust the monitor controls to meet the display you desire. The monitor stores the new display settings for the new mode. When switching between the two display modes, the monitor recalls each of the settings.

## User Modes

Modes 13 – 36 are empty and can accept new video data. If the monitor detects a new video mode that has not been present before or is not one of the preset modes, it stores the new mode automatically in one of the empty modes starting with mode 13.

If these 24 modes are already filled and your video card generates a new mode, it will overwrite the previous mode starting at mode 13. In this manner, you will always have the most recent 24 modes available.

## Recalling Display Modes

When your monitor detects a mode it has seen before, it automatically recalls the image settings you may have made the last time you used that mode. You may, however, manually force a recall of each of the 12 preset modes by selecting the Recall Mode icon. All preset modes are automatically recalled as the monitor senses the incoming signal.

The ability to recall the preset modes is dependent on the signal coming from your PC's video card or system. If this signal does not match any of the factory modes, the monitor automatically sets itself to display the image.



**NOTE:** You may customize the factory modes by following the same procedure used for image adjustment.

## Servicing

### Cleaning the Monitor

Special attention should be taken when cleaning the S-coating of the monitor screen. To clean the screen:

1. Unplug the monitor.
2. Clean the monitor with a soft, slightly damp cloth. **Do not** use an aerosol cleaner directly on the screen.



**NOTE:** Do not use benzene, thinner, or any volatile substance to clean the monitor, as these products may discolor the monitor's cabinet. Likewise, do not place rubber or vinyl on the monitor.

## Maintenance and Troubleshooting

### Identifying and Correcting Problems

The following can be sources of problems:

- Communications cables
- Host system
- Nearby power or electrical sources

### Self Diagnostics

This monitor can sense when there is a possible problem present and informs you of this condition by presenting you with a *Self Diagnostic* OSD. This OSD may pop up when it is *on*, but no signal is detected. In this case, the message "CHECK : INPUT SIGNAL" is highlighted alerting you to check the signal cable connections.



## Troubleshooting Table

Use Table 5 to identify and correct any problems areas.

**Table 5. Identifying and Correcting Problems**

Symptom	Possible Cause	Suggested Solution
Display does not appear.	Brightness or contrast control is set too low. Power Management feature is active in the off state. There is no power.	Increase the brightness and contrast control settings to suit you. Press any key and allow 20 seconds for monitor to warm up. Check the power cord. Use another ac outlet.
Image is not correctly shaped.	A new mode is selected. User controls have not yet been adjusted.	Use the OSD adjustment controls to adjust the image.
Color impurity	Magnetic fields can build up on the CRT.	In the OSD adjustments, select the Option Select icon and the Manual Degaussing icon to demagnetize the CRT.
Video displays has moving dots and distorted lines. The display rolls or flickers.	There is electromagnetic interference.	Move any electromagnetic device, such as a fan or motor, away from the monitor or move the monitor.



**WARNING:** Serious shock hazards exist inside this display. There are no user serviceable parts inside. DO NOT remove the covers under any circumstances or attempt to service the monitor yourself. Call a qualified service representative.

## Specifications

### Monitor Specifications

Table 6. Monitor Specifications

<b>Monitor</b>	<b>PCXAV-Tx</b>
Diagonal	48.3 cm (19 in), 45.7 cm (18 in) maximum viewable
Active Area	36.0 x 27.0 cm (14.17 x 10.63 in)
<b>Cabinet</b>	
Height	46.7 cm (18.4 in)
Width	46.7 cm (18.4 in)
Depth	47.8 cm (18.8)
Weight	22 Kg (48.5 lb)
Swivel	±45°
Tilt	-5° to +13.5°
<b>Video Signal</b>	0.7 V p-p R, G, B color; separate Sync (positive or negative); 75 Ω TTL
Horizontal Scan Rate	30 - 95 kHz (automatic)
Vertical Scan Rate	50 - 150 Hz (automatic)
Connector	15-pin D-sub
<b>Power input</b>	90 - 132, 176-264 Vac, 2.0 A. maximum, 50/60 Hz.
<b>Environment</b>	
Operating Temperature	0 - 40°C
Humidity	10 - 90% relative humidity (noncondensing)

## Power Management System

The monitor has three power-saving states indicated by the LED on the front panel. When this monitor is used with a Green or EPA Energy Star PC, or a PC with VESA DPMS protocol, this monitor can conserve significant energy by reducing power consumption during periods of non-use. For proper operation of this Power Management System, make sure that the monitor signal cable is connected to the host system and that the host is On.

**Table 7. Power Saving States**

LED	Mode	H. Sync	V. Sync	Power Consumption (Watts)*	Recovery Time
Green	Normal	On	On	120 (max)	n/a
Amber	Standby	Off	On	< 15	3 s
Amber	Suspend	Off	Off	< 15	3 s
Amber	Off	On	Off	< 8	15 s

\*These power-saving states exceed the Environmental Protection Agency (EPA) Energy Star requirements using the Video Electronics Standards Association (VESA) methodology for Display Power Management Signals.

## Environment, Health and Safety

This monitor has been designed and manufactured to minimize the impact to the environment.

### Acoustic Levels

Preliminary declared values per ISO 9296 and ISO 7779:

	Sound Power Level <sup>1</sup>		Sound Pressure Level <sup>2</sup>	
	L <sub>Wad</sub> B		L <sub>pAm</sub> dBA	
	Idle	Operate	Idle	Operate
PCXAV-Tx	N/A	2.9	N/A	21

<sup>1</sup> 1 B = 10 dBA

<sup>2</sup> Operator position

**Asbestos**

This monitor does not use asbestos in any form.

**Chlorinated Solvents**

No chlorinated solvents are used in the manufacture of components in these monitors.

**Cadmium Content in CRT**

The surface layer of CRTs in these monitors do not contain cadmium in any form.

**Flame Retardants**

The enclosures for these monitors do not contain organically bound chlorine or bromine and do not emit toxic dibenzofuran or dibenzodioxin gases.

**Ozone Depleting Substances (ODS)**

These monitors are in full compliance with the labelling requirements in the U.S. Clean Air Act Amendments of 1990. They do not contain, nor are they manufactured with, a Class 1 ODS, as defined in Title VI section 611 of this act.

**Enclosure Plastics**

The plastic enclosures are not made of rigid PVC. The material has a non-halogenated, flame-retardant system and is cadmium free.



## Environmental Labelling of Personal Computers

Congratulations! You have just purchased a TCO'95 approved and labelled product! Your choice has provided you with a product developed for professional use. Your purchase has also contributed to reducing the burden on the environment and to the further development of environmentally-adapted electronic products.

### Why do we have environmentally-labelled computers?

In many countries, environmental labelling has become an established method for encouraging the adaptation of goods and services to the environment. The main problem as far as computers and other electronic equipment are concerned is that environmentally harmful substances are used both in the products and during their manufacture. Since it has not been possible so far for the majority of electronic equipment to be recycled in a satisfactory way, most of these potentially damaging substances sooner or later enter Nature.

There are also other characteristics of a computer, such as energy consumption levels, that are important from both the working and natural environment viewpoints. Since all types of conventional electricity generation have a negative effect on the environment (acidic- and climatic-influencing emissions, radioactive waste, etc.), it is vital to conserve energy. Electronic equipment in offices consumes an enormous amount of energy, since it is often routinely left running continuously.

### What does labelling involve?

This product meets the requirements for the TCO'95 scheme, which provides for international environmental labelling of personal computers. The labelling scheme was developed as a joint effort by the TCO (The Swedish Confederation of Professional Employees), Naturkyddsföreningen (The Swedish Society for Nature Conservation), and NUTFK (The National Board for Industrial and Technical Development in Sweden), and SEMKO AB (an international certification agency).

The requirements cover a wide range of issues: environment, ergonomics, usability, emission of electrical and magnetic fields, energy consumption and electrical and fire safety.

The environmental demands concern, among other things, restriction on the presence and use of heavy metals, brominated and chlorinated flame retardants, CFCs (freons), and chlorinated solvents. The product must be prepared for recycling, and the manufacturer is obliged to have an environmental plan, which must be adhered to in each country where the company implements its operational policy.

The energy requirements include a demand that the computer and/or display, after a certain period of inactivity, shall reduce its power consumption to a lower level, in one or more stages. The length of time to reactivate the computer shall be reasonable for the user.

Labelled products must meet strict environmental demands, for example, in respect of the reduction of electric and magnetic fields, along with physical and visual ergonomics and good usability.

The following is a brief summary of the environmental requirements met by this product. The complete environmental criteria document may be ordered from:

TCO Development Unit  
Linnegatan 14, S-11494 Stockholm, Sweden  
FAX +46-8 782 92 07  
E-mail (Internet): [development@tco.se](mailto:development@tco.se)

Current information regarding TCO'95 approved and labelled products may also be obtained on the Internet using the address:  
<http://www.tco-info.com/>

TCO'95 is a co-operative project between:



Naturskydds  
föreningen



Närings- och teknikutvecklingsverket

SEMKO

## TCO'95 Environmental Requirements

**Brominated flame retardants** are present in printed circuit boards, cabling, casings, and housings, and are added to delay the spread of fire. Up to 30% of the plastic in a computer casing can consist of flame-retardant substances. These are related to another group of environmental toxins, PCBs, and are suspected of giving rise to similar harm, including reproductive damage in fish-eating birds and mammals. Flame retardants have been found in human blood, and researchers fear that they can disturb fetus development.

Bio-accumulative<sup>1</sup> TCO'95 demands require that plastic components weighing more than 25 grams must not contain flame retardants with organically bound chlorine or bromine.

**Lead** can be found in picture tubes, display screens, solder, and capacitors. Lead damages the nervous system and in higher doses causes lead poisoning. The relevant bio-accumulative TCO'95 requirement permits the inclusion of lead, as no replacement has yet been developed.

**Cadmium** is present in rechargeable batteries and in the color-generating layers of certain computer displays. Cadmium damages the nervous system and is toxic in high doses. The relevant bio-accumulative TCO'95 requirement states that batteries may not contain more than 25 ppm (parts per million) of cadmium. The color-generating layers of display screens must not contain any cadmium.

**Mercury** is sometimes found in batteries, relays and switches. Mercury damages the nervous system and is toxic in high doses. The relevant bio-accumulative TCO'95 requirement states that batteries may not contain more than 25 ppm of mercury and that no mercury is present in any of the electrical or electronic components concerned with the display unit.

**CFCs** (freons) are sometimes used for washing printed circuit boards and in the manufacture of expanded foam for packaging. CFCs break down ozone and thereby damage the ozone layer in the atmosphere, causing increased reception on Earth of ultra-violet light with consequent increased risks of skin cancer (malignant melanoma). The relevant TCO'95 requirement: Neither CFCs nor HCFCs may be used during the manufacture of the product or its packaging.

---

<sup>1</sup> Bio-accumulative means that the substance accumulates within living organisms.

## Shipping Package

The packaging material can be recycled, or you can save it to return the monitor to a service center for repair or disposal.

## CFC Compounds in Distribution Packaging

Cushioning material used for shipping finished monitors are not manufactured with nor do they contain any CFC compounds.

## Design for Disassembly/Recycling

These monitors have been designed for easy end-of-life disassembly and recycling. Fasteners are generally of the same type for efficient disassembly. Components made of different materials can be easily separated and plastics have been identified using international symbols to aid in recycling.

## Monitor Disposal



**WARNING:** If you need to dispose of a monitor, ask a qualified service representative for the proper procedure. Improper disposal could result in personal injury from implosion.



## Monitor Registration

The model and serial number of the monitor are located on the back of the unit. Record these numbers in the space provided below. Staple your receipt to this page as proof of purchase.

Date of Purchase: \_\_\_\_\_

Dealer: \_\_\_\_\_

Dealer's address: \_\_\_\_\_

Dealer's phone number: \_\_\_\_\_

Model No. \_\_\_\_\_

Serial No. \_\_\_\_\_