

DIGITAL Personal Workstation

Service Maintenance Manual

Part Number: ER-K3BWW-SM. A01

December 1997

The information in this document is subject to change without notice and should not be construed as a commitment by Digital Equipment Corporation.

Digital Equipment Corporation assumes no responsibility for any errors that might appear in this document.

The software described in this document is furnished under a license and may be used or copied only in accordance with the terms of such license. No responsibility is assumed for the use or reliability of software or equipment that is not supplied by Digital Equipment Corporation or its affiliated companies.

Restricted Rights: Use, duplication, or disclosure by the U.S. Government is subject to restrictions as set forth in subparagraph (c) (1) (ii) of the Rights in Technical Data and Computer Software clause at DFARS 252.227-7013.

DIGITAL Personal Workstation Service Maintenance Manual

Copyright © Digital Equipment Corporation.

All Rights Reserved.

DEC and the DIGITAL logo are registered trademarks of Digital Equipment Corporation.

Intel is a registered trademark of Intel Corporation.

Pentium-Pro and Pentium II are registered trademarks of Intel Corporation.

Microsoft and Windows NT are registered trademarks of Microsoft Corporation.

SIMM is a registered trademark of Wang Laboratories.

All other trademarks and registered trademarks are the property of their respective holders.

FCC Notice

This equipment has been tested and found to comply with the limits for a Class B digital device, pursuant to Part 15 of the FCC rules. These limits are designed to provide reasonable protection against harmful interference in a residential installation.

Any changes or modifications made to this equipment may void the user's authority to operate this equipment.

This equipment generates, uses, and can radiate radio frequency energy and, if not installed and used in accordance with the instructions, may cause harmful interference to radio communications. However, there is no guarantee that interference will not occur in a particular installation. If this equipment does cause harmful interference to radio or television reception, which can be determined by turning the equipment off and on, the user is encouraged to try to correct the interference by one or more of the following measures:

- Reorient or relocate the receiving antenna
- Increase the separation between the equipment and receiver
- Connect the equipment into an outlet on a circuit different from that to which the receiver is connected
- Consult the dealer or an experienced radio/TV technician for help

The user may find the following booklet prepared by the Federal Communications Commission helpful: How to Identify and Resolve Radio-TV Interference Problems. This booklet is available from the U.S. Government Printing Office, Washington, D.C., 20402. Stock No. 004-00398-5.

All external cables connecting to this basic unit need to be shielded. For cables connecting to option boards, see the option manual or installation instructions.

Canadian DOC Notice

This digital apparatus does not exceed the Class B limits for radio noise emissions set out in the radio interference regulations of the Canadian Department of Communications.

VCCI Notice

This equipment is in the 2nd Class category (information equipment to be used in a residential area or an adjacent area thereto) and conforms to the standards set by the Voluntary Control Council For Interference by Data Processing Equipment and Electronic Office Machines aimed at preventing radio interference in such residential area.

When used near a radio or TV receiver, it may become the cause of radio interference.

Read the instructions for correct handling.

German Ergonomic Notice

This equipment meets or exceeds the ergonomic requirements of ZH1/618 and is certified to bear the GS mark by TUV Rheinland of Germany.

Safety Requirements

This equipment meets or exceeds requirements for safety in the U.S. (UL 1950), Canada (CSA C22.2 No. 950), and Europe (EN 60950/IEC 950) with Nordic requirements.



WARNING: There is a danger of battery explosion if a lithium battery is incorrectly replaced. To prevent damage to your computer, be sure the + side faces up when installing a new battery. Also, be sure you replace the battery with either a DIGITAL (P/N 12-41474-05), Toshiba (P/N CR2032), or equivalent 3 V dc lithium battery.

Depending on your locality, your computer's battery might be considered hazardous waste. Make sure you follow any state or local statute to properly dispose of the old battery.



ADVARSEL: Der er fare for, at et lithiumbatteri eksploderer, hvis det udskiftes ukorrekt. Undgå, at beskadige din computer - HUSK, at + siden skal vende opad, når du installerer et nyt batteri. Du skal udskifte batteriet med enten et DIGITAL (delnummer 12-41474-05), Toshiba (delnummer CR2032), eller tilsvarende 3 V jævnstrøms lithiumbatteri.

Afhængig af dit lokalområde, er det muligt, at din computers batteri betragtes som farligt affald. Husk, at følge evt. miljølove og lokale bestemmelser, når du kasserer det gamle batteri.



VAROITUS: Litiumpatterit voivat räjähtää, jos ne asennetaan väärin. Estääksesi tietokoneesi vaurioitumisen varmista, että patteria asentaessasi sen positiivinen (+) puoli on ylöspäin. Tarkista myös, että käyttämäsi uusi patteri on joko DIGITAL (osa no. 12-41474-05), Toshiba (osa no. CR2032) tai vastaavanlainen 3 voltin tasavirtalitiumpatteri.

Asuinpaikastasi riippuen tietokoneesi patteria voidaan pitää ongelmajätteenä. Pidä huoli, että hävität vanhan patterin voimassa olevien lakien ja asetusten mukaisesti.



WARNING! Det kan förekomma en batteriexplosion om ett litiumjonbatteri byts ut på felaktigt sätt. Förhindra att datorn skadas genom att se till att plussidan (+) är uppåtvänd när du sätter i ett nytt batteri. Det gamla batteriet får endast bytas ut mot ett DIGITAL-batteri (artikelnummer 12-41454-05), ett Toshiba-batteri (artikelnummer CR2032) eller ett motsvarande litiumbatteri på 3 volt likström.

Datorbatterier anses vara miljöfarligt avfall i många länder. Du måste följa alla lokala bestämmelser när du avyttrar ett gammalt batteri.

Laser Safety Notices

All CD-ROM drives included in DIGITAL computers are classified as Class 1 laser products and comply with safety standards as set by U.S. government and applicable European agencies.

No hazardous radiation is emitted from this CD-ROM drive; the laser beam is completely enclosed in the CD-ROM subassembly during all customer operation and maintenance. In the event that repair or service of the CD-ROM subassembly is required, only authorized DIGITAL service personnel should perform such repairs.

Contents

1

Product Description

Introduction	1-1
DIGITAL Personal Workstations with Windows NT 4.0	1-2
Related Material	1-3
Latest Product Information and Updates.....	1-4

2

BIOS Setup Utility

Running the BIOS Setup Utility.....	2-1
Helpful Hints	2-2
BIOS Setup Utility Options	2-3
Main	2-4
Advanced.....	2-11
Security Options	2-15
Power	2-17
Boot.....	2-18
Flash Utility	2-19

Contents

3

System Software

Introduction	3-1
Factory-Installed Software.....	3-2
Applications	3-3
ClientWORKS.....	3-4
Self Monitoring Analysis Technology (S.M.A.R.T.)	3-5
Operating System Kit	3-5
System Software CD and Supplied Diskettes	3-6
Configuring Video.....	3-6
Configuring Networking	3-7
Configuring Additional Hardware	3-7
Using Diagnostics	3-7
Restoring the Workstation's Software.....	3-8
Additional Device Drivers	3-9

4

Troubleshooting

Initial Troubleshooting	4-1
Pass/Fail Criteria.....	4-3
Diagnostics	4-4
ClientWORKS and DMI.....	4-5
Self Monitoring Analysis Technology (S.M.A.R.T.).....	4-6
Advanced Troubleshooting.....	4-7
Workstation Troubleshooting.....	4-8
Disk Drive Troubleshooting.....	4-22
Monitor Troubleshooting.....	4-24
Audio Troubleshooting.....	4-26
CD-ROM Troubleshooting	4-28
Network Interface Troubleshooting	4-29
Error Messages.....	4-30
POST Messages.....	4-30
POST and Boot Messages.....	4-31
POST Execution Messages.....	4-34
Beep Codes	4-35

5

Parts Replacement

Introduction	5-1
DIGITAL Personal Workstation IPB List	5-2
Enclosure.....	5-4
Storage Devices	5-5
SCSI and Video Adapter Cards.....	5-6
CPU Retention Assembly.....	5-6
Cables and Terminator.....	5-7
Miscellaneous	5-8
Service Procedures.....	5-9
Recommended Tools	5-9
Other Materials Needed	5-9
Special Tools Required	5-9
Remedial Diagnostic Test Software.....	5-10
Virus Software Information	5-10
BIOS Version Information	5-10
Disconnecting External Devices and Power.....	5-10
Removing the Workstation's Outside Cover.....	5-11
Workstation Components	5-13
Main Logic Board Components.....	5-13
Main Logic Board Connectors (Rear Panel).....	5-15
Main Logic Board Jumper and Switch Settings	5-17
Pentium® II Processor Module Switch Settings	5-19
Adding Additional Workstation Memory	5-20
Memory Configurations	5-22
Adding Video Memory.....	5-23
Removing and Replacing Components	5-24
Removing the Main Logic Board.....	5-25
Removing the DIMMs	5-27
Removing the Lithium Battery	5-29
Removing the Processor Module.....	5-31
Removing the Voltage Regulator Module (VRM)	5-32
Removing the Terminator Module	5-34
Removing Expansion Boards	5-36
Removing the Power Supply	5-37
Removing the Control Panel Assembly and Cable.....	5-39

DIGITAL PERSONAL WORKSTATION

Contents

Removing the Option Card Assembly	5-41
Removing the Wire Assembly, Headphone/Microphone	5-43
Removing the Front Bezel Door	5-45
Removing the Front Bezel.....	5-47
Removing a 3½-Inch Device from Front Bay	5-49
Removing a 5¼-Inch Device	5-51
Removing an Internal 3½-Inch Device.....	5-53
IDE Drive Connections.....	5-55
SCSI Drive Connections	5-57
Removing the Diskette Drive.....	5-59
Diskette Drive Connections.....	5-61

6

Device Mapping

Introduction	6-1
Full Range Processor Memory Address Map.....	6-2
I/O Address Map.....	6-3
Interrupt Levels	6-5
DMA Channel Assignment	6-6

7

Service Notes	7-1
----------------------------	-----

Figures

5-1. DIGITAL Personal Workstation.....	5-3
5-2. Removing the Outside Cover.....	5-12
5-3. Main Logic Board Components.....	5-14
5-4. Main Logic Board Components (Rear Panel)	5-16
5-5. Main Logic Board Switch Locations	5-18
5-6. Pentium® II Processor Module Switch Locations	5-20
5-7. DIMM Socket Locations.....	5-21
5-8. Video Memory Socket Location	5-23
5-9. Removing the Main Logic Board.....	5-26
5-10. Removing DIMMs.....	5-28
5-11. Removing the Lithium Battery.....	5-30
5-12. Removing the Pentium II Processor Module.....	5-31
5-13. Removing the VRM.....	5-33
5-14. Removing the Terminator Module.....	5-35

Contents

5-15. Removing Expansion Boards.....	5-36
5-16. Removing the Power Supply.....	5-38
5-17. Removing the Control Panel Assembly and Cable	5-40
5-18. Removing the Option Card Assembly.....	5-42
5-19. Removing the Wire Assembly, Headphone/Microphone	5-44
5-20. Removing the Front Bezel Door.....	5-46
5-21. Removing the Front Bezel.....	5-48
5-22. Removing a 3½ -inch Device from the Front Bay	5-50
5-23. Removing a 5¼-Inch Device.....	5-52
5-24. Removing an Internal 3½-Inch Device.....	5-54
5-25. IDE Device Data Cable Connections	5-56
5-26. SCSI Device Data Cable Connections	5-58
5-27. Removing the Diskette Drive.....	5-60
5-28. Diskette Device Data Cable Connections	5-62

Contents

Preface **P**

This *Service Maintenance Manual* is a troubleshooting guide that can be used for reference when servicing DIGITAL Personal Workstations.

DIGITAL reserves the right to make changes to this *Service Maintenance Manual* without notice. Accordingly, the illustrations and procedures in this document might not apply to all DIGITAL Personal Workstations to be serviced since many of the diagnostic tests are designed to test more than one product.



CAUTION: DIGITAL recommends that only A+ certified engineers attempt to repair this equipment. All troubleshooting and repair procedures are detailed to support subassembly/module level exchange. Because of the complexity of the individual boards and subassemblies, no one should attempt to make repairs at the component level or make modifications to any printed circuit board. Improper repairs can create a safety hazard. Any indications of component replacement or circuit board modifications might void any warranty or exchange allowances.

Preface

Product Description **1**

Introduction

DIGITAL Personal Workstations are high-performance workstations featuring the latest in computing technology. They can be used as stand-alone computers, as clients, or as servers in a network environment. Developed using the following state-of-the-art technology, these workstations are the most value packed workstations in their class.

- *Microprocessor*— DIGITAL Personal Workstations offer a single or dual 266 or 300 MHz Pentium® II processors with MMX Slot 1 configurations, with 512 KB on-chip level 2 cache (each processor).
- *Memory*— Up to 512 MB of workstation memory, via four DIMM sockets, using 128 MB DIMMs (when 256MB DRAM is available)
- *Plug and Play*— Optional Plug and Play compatible expansion boards are automatically configured for easy installation.
- *PCI local bus*— The workstation's PCI architecture represents the latest in local bus technology.
- *Video expansion board*— Video expansion board that supports 2D/3D performance. Also contains built-in video playback acceleration to enhance multimedia applications.
- *Onboard Ethernet*— Single-chip DIGITAL 21143 PCI Ethernet LAN controller for PCI bus: PCI bus clock up to 33 MHz, independent of network clock. Full duplex operation supports IEEE, ANSI, and Ethernet standards. Offers 10/100Base-TX support.

Product Description

- *Onboard audio*— 16-bit stereo sound circuit supports business and SoundBlaster Pro applications. The internal workstation speaker is connected to the audio system with volume control (selected in the BIOS Setup utility) as the default output device.
- *SCSI adapter*— 32-bit ultra-wide SCSI (UW-SCSI) adapter that supports 50-pin narrow, 68-pin wide, and 68-pin ultra-wide SCSI devices.

DIGITAL Personal Workstations with Windows NT 4.0

Part Number	Description	Video	HDD	RAM	Additional Features
SN-K3B5W-VA	6200 ST	Permedia P2 graphics	4.3 GB EIDE	32 MB	Diskette drive, 24x CD-ROM, 10BaseT/10Base2 Ethernet, 16-bit Audio, 512 KB on-chip cache, U.S. Country Kit
SN-K3B5W-VB	6200 ST	Permedia P2 graphics	None	64 MB	Diskette drive, 24x CD-ROM, 10BaseT/10Base2 Ethernet, 16-bit Audio, 256 KB on-chip cache, U.S. Country Kit
SNK3B6W-VA	6300 ST	Permedia P2 graphics	None	64 MB	Diskette drive, 24x CD-ROM, 10BaseT/10Base2 Ethernet, 16-bit Audio, 256 KB on-chip cache, U.S. Country Kit
SN-K3B6W-VC	6300 ST	Permedia P2 graphics	4.3 GB Ultra SCSI	64 MB	Diskette drive, 24x CD-ROM, 10BaseT/10Base2 Ethernet, 16-bit Audio, 256 KB on-chip cache, Ultra-Wide SCSI Adapter, U.S. Country Kit
SN-K3B6W-VD	6300 ST	PowerStorm 4D30T graphics	4.3 GB Ultra SCSI	64 MB	Diskette drive, 24x CD-ROM, 10BaseT/10Base2 Ethernet, 16-bit Audio, 256 KB on-chip cache, Ultra-Wide SCSI Adapter, U.S. Country Kit

Related Material

The following related material is available:

Document Title	Order Number	Description
Service Quick Reference	ER-K3BWW-SR	Provides troubleshooting information that can be used when servicing DIGITAL Personal Workstations.
Quick Setup Guide	ER-K3BWW-IM (Multilanguage)* ER-B30WW-IJ (Japanese)	Describes how to initially setup DIGITAL Personal Workstations.
System Reference	ER-K3BWW-UA (English) ER-K3BWW-UJ (Japanese)	Describes how to operate, configure, and upgrade DIGITAL Personal Workstations.
System Solutions	ER-PCDSS-UA (English) ER-PCDSS-UM (Multilanguage)* ER-PCDSS-UJ (Japanese)	Provides end-user troubleshooting information should a DIGITAL Personal Workstation fail to operate after initial setup or after installing optional devices.
System Software	ER-K3BWW-GA (English) ER-K3BWW-GM (Multilanguage)*	Provides information on the operating system, utilities, and device drivers that came with DIGITAL Personal Workstations.
Warranty and Service	EK-PCHWW-CM (Multilanguage)*	Provides warranty information and a listing of phone numbers for technical support.
Backup Media Kit	QC-04J8A-HW	DIGITAL Personal Workstation Backup Media Kit.

* Multilanguage includes: English, French, Italian, German, and Spanish.

README files come with the factory installed software and on the supplied backup CD-ROM disc. These files contain useful setup, configuration, and operation information. Read this information first.

Product Description

Latest Product Information and Updates

Access product information and download the latest BIOS, device drivers, and software updates using the Internet at:

<http://www.workstation.digital.com>

1. To get to the file library, choose **Service & Support**.
2. At the next screen, under **Firmware & Drivers**, select the Intel-based System Library.
3. Choose the correct model from the displayed list.
4. From the file list, choose the file to download.

BIOS Setup Utility **2**

Running the BIOS Setup Utility

The BIOS Setup utility enables you to select and store permanently information about the workstation's hardware and software in the battery-backed memory of the CMOS RAM. This information takes effect each time the workstation boots and can be changed any time you run setup.

You should use the BIOS Setup utility if you experience problems with the hard disk or if you need to reconfigure or expand the workstation. In addition, the BIOS Setup utility might need to be used to modify the configuration after adding or removing hardware, or changing workstation settings.



CAUTION: The workstation was setup for normal operation at the factory and will operate properly without additional configuring.

It is important for you to read carefully and understand this chapter before attempting to modify the workstation's factory settings. Changing some settings might cause the workstation to operate improperly.

To access the BIOS Setup utility, perform the following steps:

1. Turn on the workstation and allow the Power-On Self Test (POST) to complete.
2. Make a note of any configuration errors listed, and then press [F2] to display the Main menu.
3. Follow the instructions on the monitor screen and any on-line help pop-up screens to configure you workstation.

Helpful Hints

- Several keyboard keys are assigned to help you select menus and sub-menus, options, change option values, and display help information. These keys are displayed at the bottom of the main menu and from the General Help pop-up screen.
- Item-specific help is available anytime during the setup process and appears at the right of the setup screen when an option is highlighted. This on-line help provides information about a highlighted option.
- Select *Save Changes & Exit* to save all Setup values and exit Setup.
- Select *Exit Without Saving Changes* to exit Setup without recording any changes.
- Select *Get Default Values* to set all Setup options to their default values.
- Select *Load Previous Changes* to restore all CMOS values from the last session.
- Select *Save Changes* to save all selections without exiting Setup.
- Press [Esc] to exit the BIOS Setup utility.

BIOS Setup Utility Options

The following Help topics list the BIOS options that can be updated or modified by using the BIOS Setup utility, according to the various sub-menus under which they appear.

- Main Menu Options — Sets basic workstation configuration options (time, date, video, etc.).
- Advanced Options — Sets advanced features to increase workstation performance (COM ports, LPT ports, etc.).
- Security Options — Sets passwords and backup data reminders.
- Power Options — Sets power saving options to increase the life of the workstation.
- Boot Options — Sets the boot sequence of the computer.
- Exit — Provides options for saving changes and leaving the BIOS Setup utility. Refer to “Navigating,” in the BIOS Setup utility, for additional information.



NOTE: The following tables list the BIOS Setup Menu options available for DIGITAL Personal Workstations. Note that an “ * ” that follows an option in the Settings column indicates the factory default setting.

BIOS Setup Utility

Main

Menu Fields	Settings	Comments
System time	Current time	Displays the current time.
System date	Current date	Displays the current date.
Language	English*	Language default.
Diskette drive A/ Diskette drive B	1.44 MB, 3½* 2.88 MB, 3½ Not Installed* 360 KB, 5¼ 1.2 MB, 5¼ 720 KB, 3½	Sets the size and density of diskette drives.
Integrated IDE adapter	Disabled Both* Primary Secondary	Enabled or disables the local bus IDE adapter. Both enables both the primary and secondary adapters. Primary enables only the primary adapter and Secondary enables only the secondary adapter.

IDE Adapter 0/1 Master/Slave

Autotype fixed disk	[Press Enter]	Press [Enter] to detect and fill in the installed hard disk drive parameters in the remaining fields.
Type ⁽¹⁾	None 1 to 14 Rsrv 16 to 39 User Auto* CD	Selecting 1 to 14 and 16 to 39 automatically fills in the remaining fields in this menu. Selecting User enables the remaining fields to be filled in manually, using the installed hard disk drive's parameters. ⁽²⁾ If a CD-ROM drive is used for the IDE drive, you must select CD. You can select Auto for an HDD.

⁽¹⁾ These fields are automatically filled in if the workstation auto-detected an installed hard disk drive.

⁽²⁾ Incorrect settings can cause the workstation to malfunction.

continued

Menu Fields	Settings	Comments
Cylinders ⁽¹⁾	0 to 4095	Displays the number of cylinders.
Heads ⁽¹⁾	1 to 64	Displays the number of heads.
Sectors/track ⁽¹⁾	0 to 63	Displays the number of sectors/track.
Write precomp ⁽¹⁾	0 to 4095 None	Displays the number of cylinders that have their write timing changed.
Multi-sector transfers ⁽¹⁾	Disabled 2 sectors 4 sectors 8 sectors 16 sectors Auto	Determines the number of sectors per block for multiple sector transfers. Auto refers to the size the disk returns when queried.
LBA control mode	Disabled Enabled*	Enabling this option causes Logical Block Addressing (LBA) instead of cylinders and heads. Select <code>Disabled</code> for IDE hard disk drives that are up to 528 MB in size. When using an IDE drive larger than 528 MB and an operating system that supports LBA, select <code>Enable</code> . MS-DOS and Windows are examples of operating systems that support LBA.
32-bit I/O	Enabled* Disabled	Enables or disables the 32-bit, hard disk drive data transfer option. Enabling this option speeds up data transfers; ensure that the HDD supports 32-bit I/O transfers.
Ultra DMA transfer mode	Disabled Mode 0 Mode 1 Mode 2	Selects the Ultra DMA method to transfer data to and from the HDD.
Transfer mode ⁽¹⁾	Standard Fast PIO1 Fast PIO2 Fast PIO3 Fast PIO4 Fast DMA A Fast DMA B Fast DMA F	Selects the method to transfer data to and from the HDD. If you select the user autotype for the HDD, Setup automatically selects the optimum transfer mode.

DIGITAL PERSONAL WORKSTATION

⁽¹⁾ These fields are automatically filled in if the workstation auto-detected an installed hard disk drive.

continued

BIOS Setup Utility

Menu Fields	Settings	Comments
Video system	EGA / VGA* CGA 80x25 Monochrome	Sets the video controller type.
Memory and Cache:		
Internal cache	Enabled* Disabled	Enables or disables the processor's internal cache.
External cache	Enabled* Disabled	Enables or disables the external cache.
Cache system BIOS	Enabled* Disabled	This option enables the system BIOS to be cached in the internal cache and external cache (if installed). This increases workstation performance because BIOS instructions can be executed in cache instead of RAM. Enabled is the recommended setting.
Cache video BIOS	Enabled* Disabled	This option enables the video BIOS to be cached in the internal cache and external cache (if installed). This increases workstation performance because video BIOS instructions can be executed in cache instead of RAM. Enabled is the recommended setting.
System BIOS shadow	Enabled*	Always set to Enabled.

continued

Menu Fields	Settings	Comments
Video shadow	Enabled* Disabled	The main logic board reserves an area of DRAM for a copy of video BIOS ROM. This DRAM called "shadow memory" is write-protected and has the same addresses as the video BIOS ROM locations. When video BIOS ROM is shadowed, the ROM information is copied into an appropriate area in DRAM. This increases the workstation's performance because the video BIOS instructions are in fast DRAM instead of ROM. Enabled is the recommended setting.
Shadow memory region C800 - CBFF: CC00 - CFFF: D000 - D3FF: D400 - D7FF: D800 - DBFF: DC00 - DFFF:	Enabled Disabled*	Enables or disables shadowing of individual segments of ROM to increase workstation performance. CAUTION: Some option ROMs do not operate properly when shadowed.

continued

DIGITAL PERSONAL WORKSTATION

BIOS Setup Utility

Menu Fields	Settings	Comments
AT bus space	Disabled*	Memory hole not available; upper memory is contiguous.
	F00000h, 1 MB	Sets the memory hole at address F00000 with 1 MB memory available.
Extended memory report	Compatibility* Non-compatibility	Select the BIOS report mechanism for the amount of external memory. Select <i>Compatibility</i> when using a conventional operating system. Select <i>Non-compatibility</i> for extended memory above 64 MB under Windows NT.
Boot Options		
Setup prompt	Enabled* Disabled	Enables or disables the <F2> setup prompt each time the workstation boots. If you select <i>Disable</i> , you only disable the prompt informing you when to press <F2> to enter Setup. You can still enter Setup by pressing <F2> before POST completes.
POST errors	Enabled Disabled*	Enabling this option causes the workstation to pause and display a setup entry or resume the boot prompt if an error occurs at boot. Disabling this option causes the workstation to always attempt to boot regardless of a setup entry or error.
Quiet boot	Enabled Disabled*	Enables or disables the display of POST messages. Quiet Boot, when enabled, displays the DIGITAL logo, instead of POST messages.

continued

BIOS Setup Utility

Menu Fields	Settings	Comments
Setup prompt	Enabled* Disabled	Enables or disables the <F2> setup prompt each time the computer boots. If <i>Disable</i> is selected, only disable the prompt when informed to press <F2> to enter Setup. Setup can still be entered by pressing <F2> before POST completes.
POST errors	Enabled* Disabled	Enabling this option causes the computer to pause and display a setup entry or resume the boot prompt if an error occurs at boot. Disabling this option causes the computer to always attempt to boot regardless of a setup entry or error.
Summary screen	Enabled* Disabled	Enabling this option causes the workstation to display configuration parameters (in the form of a summary screen) during boot.
Floppy check	Enabled* Disabled	Enabled permits verification of FDD type at boot. Disabled prevents FDD verification and speeds up the boot process.

continued

BIOS Setup Utility

Menu Fields	Settings	Comments
Keyboard Features		
NumLock	Auto* On Off	Turns NumLock on or off each time the workstation boots. If <code>Auto</code> is selected, the workstation will turn on NumLock if it detects a numeric keypad.
Key click	Disabled* Enabled	Enables or disables the audible key click feature.
Keyboard auto-repeat rate	2/sec 6/sec 10/sec 13.3/sec 18.5/sec 21.8/sec 26.7/sec 30/sec*	Sets the number of times a second to repeat a keystroke while the key is held down.
Keyboard auto-repeat delay	1/4 sec 1/2 sec* 3/4 sec 1 sec	Sets the delay time after a key is held down before it begins to repeat a keystroke.
System memory	Not user selectable	Displays the amount of base (conventional) memory each time the workstation boots.
Extended memory	Not user selectable	Displays the amount of extended memory each time the workstation boots.

Advanced

Menu Fields	Settings	Comments
Integrated Peripherals		
Mouse port	Disabled Enabled*	Enables or disables the mouse port.
Parallel port	Auto Disabled 3BC, IRQ 7 378, IRQ 7* 278, IRQ 5	Enables or disables the onboard port at the specified address. NOTE: Two devices cannot share the same IRQ. Also, choosing Disabled makes the parallel port unusable. Auto is the recommended setting.
Parallel port mode	Compatible mode Bi-directional mode* EPP 1.7 EPP 1.9 ECP-DMA1 mode ECP-DMA3 mode	Sets the onboard parallel port mode. Standard printer connection. PS/2 compatible mode and able to receive data. Enhanced parallel port mode. Selection based on what EPP version the printer supports. Only choose a mode that the parallel port device (such as a printer) supports. Check the parallel port device documentation for this information. If this information cannot be located, use the default setting. Extended capabilities port mode.

DIGITAL PERSONAL WORKSTATION

continued

BIOS Setup Utility

Menu Fields	Settings	Comments
Serial port 1	Auto Disabled 3F8, IRQ4* 2F8, IRQ3 3E8, IRQ4 2E8, IRQ3	<p>Enables or disables onboard serial port 1 at the specified address.</p> <p>Select Auto unless interrupts IRQ4 and/or IRQ3 are allocated as a computer resource.</p> <p>Two devices cannot share the same IRQ. Choosing Disabled makes serial port 1 unusable. If selecting Auto, Setup configures COM1 to address = 3F8h and IRQ = 4 if they are available.</p> <p>Auto is the recommended setting.</p>
Serial port 2	Auto Disabled 3F8, IRQ4 2F8, IRQ3* 3E8, IRQ4 2E8, IRQ3	<p>Enables or disables onboard serial port 1 at the specified address.</p> <p>Select Auto unless interrupts IRQ4 and/or IRQ3 are allocated as a computer resource.</p> <p>Two devices cannot share the same IRQ. Choosing Disabled makes serial port 1 unusable. If selecting Auto, Setup configures COM1 to address = 3F8h and IRQ = 4 if they are available.</p> <p>Auto is the recommended setting.</p>
Diskette controller	Enabled* Disabled	Enables or disables the onboard diskette controller.
Exchange diskette drives	Disabled* Enabled	Logically exchanges physical diskette drive designations.
Diskette write protection	Disabled* Enabled	Enables or disables the selected diskette drive's write protect option.
Integrated audio	Enabled* Disabled	Enables or disables the Sound Blaster Pro-compatible audio chip.

continued

BIOS Setup Utility

Menu Fields	Settings	Comments
Audio Base I/O	220H* 240H 260H 280H	Onboard audio I/O address.
MPU Base I/O	300H 310H 320H 330H*	Selects the MPU I/O address.
FM Synth Base I/O	388H* 398H 3A8H	Selects the FM Synthesizer I/O address.
Audio DMA	DMA0 DMA1* DMA3	Selects the system DMA resource to be used by the on-board sound chip.
Audio IRQ	IRQ5* IRQ7 IRQ9 IRQ11	Determines the system IRQ resource that the sound chip is to use.
Audio Play Back DMA	DMA0 DMA1 DMA3 DMA5*	Determines the system DMA resource that the sound chip is to use for playback.
System Speaker Volume	Hi* Low Medium	Determines the system speaker output volume.

continued

BIOS Setup Utility

Menu Fields	Settings	Comments
Advanced Chipset Control		
USB Device	Disabled*	Not user selectable
PCI to PCI Bridge	Enabled	Enable/Disable the PPB Palette Snoop
VGA Palette Snoop	Disabled*	
Plug & Play O/S	Yes No*	Select Yes if using a Plug & Play operating system such as Windows NT. Otherwise, select No .
Reset configuration data	Yes No*	Select Yes to clear the system configuration data if it is suspected to be corrupted, which sometimes occurs after a power outage. This option also clears the Plug & Play databases. After entering the correct settings (or accepting the default settings), the computer switches this setting back to No . If it is not necessary to clear system configuration data, leave the setting at No .
P6 BIOS Update	Enabled* Disabled	Enables/Disables P6 BIOS update
Large disk access mode	DOS* Other	Select DOS if MS-DOS is installed. Select Other if another operating system is installed. A large disk drive constitutes one that has more than 1024 cylinders, 16 heads, or 63 tracks per sector.
Integrated network controller (if available)	Enabled* Disabled	Enables or disables the onboard DIGITAL 21142 Ethernet controller.

Security Options

Menu Fields	Settings	Comments
Supervisor password is	Not user selectable (Disabled)*	Indicates whether or not the supervisor's password is enabled or disabled.
User password is	Not user selectable (Disabled)*	Indicates whether or not the user's password is enabled or disabled.
Set supervisor password	Press [Enter]	<p>Allows a supervisor password to be set.</p> <p>The supervisor password must be set if a user password is to be used.</p> <p>NOTE: Entering Setup with a supervisor password provides full access to all BIOS Setup utility menus.</p>
Set user password	Press [Enter]	<p>Allows a user password to be set.</p> <p>This password can be set only if a supervisor password is entered.</p> <p>When the user has entered his or her name but the supervisor is not logged in, only the following information is accessible:</p> <p>Supervisor password is Enabled.</p> <p>User password is Enabled.</p> <p>Set user password [press enter] to enter a user password.</p> <p>Password on boot Enabled/Disabled (which ever is in effect). This option is not allowed to change.</p> <p>Custom sign on banner Enabled/Disabled (which ever is in effect). This option is not allowed to change.</p>

continued

BIOS Setup Utility

Menu Fields	Settings	Comments
Password on boot	Enabled Disabled*	Enables or disables the enter password on boot option. If you enable this option, a user or supervisor password must be entered in order for the boot process to complete. If a user or supervisor password is not entered, the operating system cannot be accessed.
Custom sign on banner is	Not user selectable (Disabled)*	Indicates whether the custom sign on banner is enabled or disabled.
Custom sign on banner	Press [Enter]	Press [Enter] to enter a custom sign on banner that displays during POST. For example, the user might enter "Welcome to John's machine." The maximum number of characters is 50.
Diskette access	Supervisor* User	Controls who has access to diskette drives. If <code>Supervisor</code> is selected, access to the diskette drive is limited to the supervisor, who must enter his or her password. If <code>User</code> is selected, the diskette drive can be accessed by entering either the supervisor or the user password. Whatever setting is chosen, it only becomes functional if both a <code>Supervisor Password</code> and a <code>User Password</code> have been set (if the <code>User</code> setting is chosen).
Fixed disk boot sector	Normal* Write protect	Write protects the boot sector on the hard disk drive.
Network Server	Enabled Disabled*	When enabled, the system is secured at boot to prevent tampering during network operation

Power

Menu Fields	Settings	Comments
Power management	Enabled Disabled*	Enable this field to use any of the power management options. If this field is enabled and the other fields are disabled, only minimal power reduction is affected.
System standby timer	Disabled* 1 min. 5 min. 10 min. 20 min. 30 min.	<p>After a set period of workstation inactivity, the BIOS places the workstation in a standby state (medium power savings), that is, the monitor and CPU are set to power management. Any mouse or keyboard activity quickly returns the workstation to operation.</p> <p>Alternately, you can choose to disable this option and thereby not use this feature. Power management must be enabled to use this option.</p>
System suspend timer	Disabled* 1 hour 1.5 hour 2 hour 3 hour 6 hour 12 hour	<p>After a set period of workstation inactivity, the BIOS places the workstation in a suspended state (maximum power savings), that is, the monitor and fan are shut off and the CPU and hard disk are powered down. Any mouse or keyboard activity quickly returns the workstation to operation.</p> <p>If you set a timer for the field, you should also set Power Management to Enabled.</p> <p>Alternately, you can choose to disable this option and thereby not use this feature. Power management must be enabled to use this option.</p>

continued

BIOS Setup Utility

Menu Fields	Settings	Comments
Suspend lock system	Yes No*	<p>When enabled, use a Quick Suspend key sequence to lock both mouse and keyboard and place system in System Suspend. Alternatively, the system goes into Suspend Lock when the system reaches the timeout set in System Suspend Timer.</p> <p>See “Set supervisor password” and “Set user password”, if desired, in the Security Options table.</p> <p>Power management must be enabled to use this option.</p> <p>Select Quick Suspend key sequence; set timeout in System Suspend Timer for system inactivity to trigger Suspend Lock.</p> <p>To wake the system up, enter the Supervisor/User password(s).</p>

Boot

Menu Fields	Settings	Comments
Boot device sequence	1. Diskette Drive* 2. Hard Drive* 3. CD-ROM Drive*	<p>The numbers refer to the order in which the devices are addressed for the system files needed to boot the system.</p> <p>To change the order, use the Up and Down cursor keys to select the device you want to move. Then use the + and – keys, on the numeric keypad, to move the device to the desired boot order.</p>

Flash Utility

All DIGITAL Personal Workstations have BIOS software in a read-only, non-volatile memory (ROM) chip. This BIOS initializes hardware and boots the operating system when the workstation is turned on. The BIOS also provides access to other services such as keyboard and disk drives.

The workstation comes equipped with flash memory. This means that you can restore the workstation's BIOS simply by running the flash utility. If necessary, you can also upgrade the workstation's BIOS to future releases by running the flash utility along with any flash BIOS update diskette.

Instructions on how to flash your BIOS, the flash utility itself, and BIOS updates are available from the workstation web page.

BIOS Setup Utility

System Software **3**

Introduction

DIGITAL Personal Workstations come with the Windows NT Workstation operating system and the necessary device drivers pre-installed on the hard disk drive. The operating system, utilities, and device drivers are optimized for the workstation's configuration and are ready for use.

This chapter describes:

- The software and documentation that came with the workstation
- The operating system software kit
- The System Software CD-ROM disc and supplied software diskettes
- Configuring video, networking, and additional hardware
- How to use the diagnostic software
- How to restore the factory installed software using the supplied System Software CD-ROM disc
- Other device drivers
- How to get updates

System Software

Factory-Installed Software

The following table describes the software installed on the hard disk drive:

Software	Description
Operating system	Windows NT Workstation. Associated on-line documentation is included with the operating system.
Application software	See "Applications."
Device drivers	These can include drivers, such as video, mouse, and IDE. Some configurations also include audio, network, CD-ROM, or SCSI drivers

Applications

The factory-installed software includes several applications designed to make the workstation easier to use. The following table lists the software that is available for the workstation. Included in the table is information on where to locate the listed items and a brief description.

Applications	Location	Description
Adobe Acrobat Reader	Select from Program Manager the Adobe program group or select Programs and then the Adobe Reader.	Printed electronic documents can be viewed or printed using the Adobe Acrobat Reader software.
ClientWORKS	Select from Program Manager the ClientWORKS program group or select Programs and then ClientWorks.	ClientWORKS is DIGITAL's client management software designed to help network administrators lower the total cost of ownership by automating asset management tasks and managing workstations remotely.
S.M.A.R.T. Monitor	Loaded automatically in Startup. Click on the icon in the tool bar to view S.M.A.R.T. information	If the computer's hard disk drive is S.M.A.R.T. aware, DIGITAL's S.M.A.R.T. Monitor apprises the hard disk drive operation.
Alta Vista Personal Search	Select from Start/Programs/ Alta Vista Search	Alta Vista Personal Search allows you to search the Internet
Microsoft Internet Explorer	Select from Program Manager the Microsoft Internet Explorer program group or select Accessories, Internet Tools, and then Internet Explorer.	Microsoft Internet Explorer is used for accessing information on the World Wide Web (available only in English).
Video Utilities	Select the Control Panel and then Display	These include utilities such as Matrox MGA or the S3 Refresh, whichever is applicable to the workstation. Refresh utilities allows you to set the refresh rate of the display.

ClientWORKS

ClientWORKS, DIGITAL's client management software, contains a powerful set of utilities designed to help get the most out of the networking environment. Based on the Desktop Management Interface (DMI) industry-standard, ClientWORKS reduces total cost of ownership and makes DIGITAL PCs more manageable than the competition. Included, at no charge, on all new DIGITAL Personal Workstations, ClientWORKS saves MIS personnel time, reduces travel costs when diagnosing remote PCs, and improves accuracy of analysis of clients on the network.

ClientWORKS includes:

- Enhanced 32-bit DMI service layers for Windows 95 and Windows NT, and a 16-bit service layer for Windows for Workgroups.
- DIGITAL's enhanced system Management Information Format (MIF) file for industry-standard desktop management.
- Enhanced ClientWORKS browser, offering identification of DMI components, both locally and remotely.
- SNMP agent software, including a MIF-to-MIB converter for powerful remote management in heterogeneous environments.
- MIFMAKER, DIGITAL's unique utility designed to make DMI data available to Microsoft Systems Management Server (SMS).
- Diagnostics for enhanced system troubleshooting.

ClientWORKS comes factory-installed on the DIGITAL Personal Workstations. ClientWORKS includes SNMP subagents that make the computer visible to an SNMP console. Although these subagents are pre-installed, they are disabled in the factory-installed software. Before enabling the subagents, TCP/IP must be installed. To install TCP/IP, follow the Windows help instructions for installing a network protocol. Once TCP/IP is installed, the Microsoft SNMP Master Agent must be installed. For installation instructions, refer to the ClientWORKS online help and user documentation.

For additional information, including last-minute release notes, please see the README.TXT and RELNOTES.TXT files in the ClientWORKS folder on the DIGITAL computer.

Self Monitoring Analysis Technology (S.M.A.R.T.)

If the workstation's hard disk drive is S.M.A.R.T. aware and the operating system is Windows NT, DIGITAL S.M.A.R.T. will monitor the hard disk drive's operation. S.M.A.R.T. Monitor is launched when Windows NT starts and then immediately minimized, the icon placed in the toolbar. The S.M.A.R.T. aware drive is periodically polled to monitor the performance of the motors, media, heads, and electronics of the drive. If problems are detected, S.M.A.R.T. will notify and advise taking appropriate action. Click on the icon at any time, to review the status and history of any S.M.A.R.T. devices. The setup of DIGITAL S.M.A.R.T. Monitor can also be modified.

For more information, refer to the ClientWORKS and/or System Reference documentation.

Operating System Kit

DIGITAL Personal Workstations come with an operating system kit that matches the operating system installed on the workstation's hard disk drive. Use the applicable CD-ROM disc and setup diskettes to restore the workstation's operating system:

Windows NT Workstation

Windows NT Workstation: CD-ROM disc, setup diskettes, software license. *Microsoft Windows NT Installation Guide* and other documentation.

Microsoft Windows NT Installation Guide describes how to install and use Windows NT, including information about additional networking services.

System Software CD and Supplied Diskettes

Included with the workstation's accessories are a System Software CD-ROM disc and some diskettes. These are described in the following table:

<i>System Software CD-ROM disc</i>	This CD-ROM disc contains the applications, utilities, device drivers, and on-line documentation necessary to restore the workstation. This disc does not contain the operating system. See CD-INFO.TXT on the CD-ROM disc for non-operating system installation and configuration information.
<i>Windows NT Workstation System Installation diskette</i>	Use this diskette to boot the CD-ROM drive to install Windows NT Workstation.
<i>Diagnostics</i>	Provided as image files on the System Software CD-ROM disc. After creating the diskettes, you can use them to access the hard disk drive if the workstation fails to boot. This software can also be used to help troubleshoot the workstation should problems occur during normal operation. (See "Using Diagnostics.")
<i>ISA Configuration Utility (ICU)</i>	Provided as image files on the System Software CD-ROM disc. After creating the diskette, use the ICU to configure ISA non-Plug and Play or legacy expansion boards for operation with a Windows NT Workstation. Run the ICU before installing non-Plug and Play ISA expansion boards or legacy boards to determine what workstation resources are available. (See "Configuring Additional Hardware.")
<i>SCSI Drivers</i>	Provided as image files on the System Software CD-ROM disc. After creating the diskette, use the SCSI drivers to configure SCSI devices for Windows NT Workstation.

Configuring Video

Before changing the resolution or resetting a monitor type, check the monitor documentation and make the new selections based on what the monitor can support. Use the Control Panel Display option to configure the video and monitor.

Refer to the Windows NT Workstation Installation Guide and any related on-line help for configuration information.

Configuring Networking

For those workstations with onboard network capabilities, configuration information is available on the System Software CD-ROM disc.

Check the root directory on the System Software CD-ROM disc for the CD-INFO.TXT file. Read this file first for configuration and installation information.

Configuring Additional Hardware

Adding additional hardware requires configuring the workstation's IRQ and DMA settings. Use the ISA Configuration Utility (ICU) diskette to help determine the available resources.

If necessary, access the ICU on-line help for complete instructions.

Using Diagnostics

DIGITAL Personal Workstations come with diagnostic files on the System Software CD-ROM. Use these diagnostics to examine the workstation's current configuration, locate faulty components, and for troubleshooting. If the workstation fails to boot or if the diagnostic software is inaccessible from the Windows NT Workstation operating system, proceed as follows:

1. Take the CD-ROM and a blank diskette to another computer system. Insert the diskette labeled "For Emergency Use" into the diskette drive and then reboot the workstation.
2. Access the CD-ROM and locate the file "DIAGBOOT.EXE". Once the program begins, follow the instructions displayed on the monitor screen.
3. Re-boot the computer that you are having trouble with, with the bootable diskette that you just created.

Refer to the README.TXT file on each of the Diagnostics diskettes for installation instructions and for additional information about the Diagnostics package.

Restoring the Workstation's Software

Use the following procedures to restore the workstation's operating system, device drivers, and any other utilities or applications.

1. If possible, back up data and any applications.
2. Reformat the hard disk drive, if necessary. Reformat the hard disk drive if it completely failed or if it was replaced with a new one.
3. Install the operating system.

Refer to the supplied Windows NT Workstation documentation for additional information.

4. Install the necessary device drivers.

Refer to the CD-INFO.TXT file on the System Software CD-ROM disc for installation and configuration information.



NOTE: Device drivers are subject to change. If necessary, download the latest device drivers using the Internet or through DIGITAL's Bulletin Board service.

5. Install the supplied applications from the System Software CD-ROM disc.
6. Install the appropriate applications.

Additional Device Drivers

Most of the device drivers are installed at the factory. However, if additional device drivers are required and they were not installed at the factory, use the supplied System Software CD-ROM disc to install them. Network, IDE, audio, CD-ROM, and video device drivers are available for the following operating systems:

- Windows 95
- Window NT
- Windows for Workgroups
- OS/2
- SCO UNIX
- Novell NetWare



NOTE: Not all device drivers on the CD-ROM disk are supported by DIGITAL. These device drivers are supplied for your convenience only.

Check the root directory on the System Software CD-ROM disc for the CD-INFO.TXT file. Read this file first for configuration and installation information.

System Software

Troubleshooting **4**

Initial Troubleshooting

The following sections provide initial troubleshooting procedures and tables listing specific problems, probable causes, and recommended actions to take if the workstation fails after configuring it or after installing optional hardware or software.

Refer to the documentation supplied with the additional options if problems are encountered after installation.

- Keep it simple, only troubleshoot one problem at a time. Also, only make one change at a time. For example, if the IDE hard disk drive fails to boot, do not try all the suggested actions at once. Instead, start with one suggestion such as checking the cables. After securing the cables, try booting the workstation. If it does not work, try another suggestion.
- Look for abnormal workstation, keyboard, and monitor LED indications. For example, make sure the power on LED lights when you turn on the workstation and the drive access indicators light when using either the diskette drive or hard disk drive.
- If there are POST error(s), run the BIOS Setup utility and fix the problem(s) identified by the POST error(s).
- If you installed external devices, make sure all cables are correctly connected to the appropriate devices.
- If you installed devices inside the workstation, make sure nothing was bumped or jarred loose, and that all cable connections are securely in place.
- Make sure all device drivers are installed correctly.

Troubleshooting

- If the workstation hangs, soft boot the workstation (press the [Ctrl] + [Alt] + [Del] keys). If the workstation fails to boot, turn it off, wait until all disk drives completely spin down, and then turn it back on.
- Pay close attention to any error message that appears on the screen.

If the error message is workstation related, refer to the “Error Messages” section at the end of this chapter.

If the error message is Windows related, refer to any on-line help and the appropriate Windows documentation supplied with the workstation.

- Listen carefully for workstation errors in the form of beeps. Record the number of beeps and their pattern then refer to the “Error Messages” section at the end of this chapter..
- After the workstation completes the POST, press [F8] to check each line of the AUTOEXEC.NT and CONFIG.NT files. Answer Yes to allow each line to execute. If an error message appears, record it and then refer to the “Error Messages” section at the end of this chapter.
- README files come with the workstation's factory installed software or as printed material. This README information can help you setup, configure, and operate the workstation.
- Run the diagnostics software. Refer to the following section for information on accessing and running the supplied diagnostics program.
- If the workstation will not boot into Windows, use the Emergency Repair Disk to gain access to the workstation's hard disk drive. Afterwards, troubleshoot the workstation to correct any problems.

Pass/Fail Criteria

As a Final Acceptance Test, the following tests should be run to meet the Pass/Fail criteria:

1. Successful completion of the POST tests.
2. Successful completion of the following AMI module tests (one pass):

System Board	(All Tests)
Memory	(All Tests)
Video	(All Tests)
Hard Disk	(All Tests except: sequential write/read and sequential write/random read)
Floppy Disk	(All Tests)
Keyboard	(All Tests)
COM Ports	(All Tests)
LPT Ports	(All Tests)
Pointer Device	(All Tests)
3. Successful bootstrap of the workstation installed operating system.

Operating system supported:

 - Windows NT Workstation

Remove any software that was put on the hard disk drive to enable repair of the workstation before shipping.

When completed, clean the outside of the workstation with cleaning solution.

Diagnostics

The factory installed software includes an Administrative Tools group in the Program Manager menu. This program group includes a Windows NT Diagnostics icon for launching the Diagnostic software. You can use this software to troubleshoot the workstation.

The supplied diagnostic diskettes can be used to examine the workstation's current configuration, locate faulty components, and troubleshoot the workstation if you are unable to access the diagnostic software from Windows NT Workstation.

To access the diagnostic software:

1. Insert the "For Emergency Use" diskette you received into the diskette drive and then type:

```
A:\AMIDIAG
```

2. If you are unable to boot from the hard disk drive, you can instead boot directly from the "For Emergency Use" diskette.
3. Once the program begins, follow the instructions displayed on the monitor screen.

Refer to the README file on the "For Emergency Use" diskette for additional information.

ClientWORKS and DMI

ClientWORKS is a Desktop Management Interface (DMI) based software application that has been developed by Digital Equipment Corporation.

ClientWORKS for Windows NT Workstation users can be used to help you, the system manager, or system administrator to identify the workstation's current hardware configuration. This feature is useful, for example, if you need to see if you have sufficient memory or a large enough hard disk drive for the applications you want to run. System managers or system administrators can access ClientWORKS data through Simple Network Management Protocol (SNMP) consoles. This feature means the company can protect its current investment in SNMP software and network monitors. Other features include:

- If there is a known workstation component that needs to be replaced, under Windows NT Workstation, a system manager or administrator can access ClientWORKS and get the Field Replaceable Unit (FRU) part number. This part number can then be relayed to the service provider to expedite ordering.
- Serial numbers can easily be identified to obtain warranty service.
- The amount and type of workstation memory you have installed can easily be identified using ClientWORKS. This is especially useful if you need to know the workstation's capabilities prior to loading software.
- A system manager or administrator can use ClientWORKS to remotely access workstation configurations that are attached to a network. This feature enables a system manager or administrator to easily maintain an accurate equipment log.

Refer to the supplied ClientWORKS factory installed on-line help or the supplied CD-ROM disc for detailed information on using or installing either program.

Self Monitoring Analysis Technology (S.M.A.R.T.)

If the computer's hard disk drive is S.M.A.R.T. aware and the operating system is Windows NT, Digital's S.M.A.R.T. Monitor appraises the user how the hard disk drive is operating.

When Windows NT starts, DIGITAL S.M.A.R.T. Monitor is launched and then immediately minimized, placing the icon in the Windows NT taskbar. DIGITAL S.M.A.R.T. Monitor then periodically polls the S.M.A.R.T. aware devices in the computer and by clicking on the icon, the status of these devices can be reviewed. General information and drive history can also be reviewed , as well as modifying the setup of DIGITAL S.M.A.R.T. Monitor.

If problems are detected in the computer's devices, a dialog box will appear displaying an error message.

For more information on DIGITAL S.M.A.R.T. Monitor, refer to the System Reference, ClientWORKS, and/or System Software documentation.

Advanced Troubleshooting

DIGITAL has a Customer Replaceable Unit (CRU) process during the warranty period for:

- DIGITAL monitors with screens less than 20 inches
- Mice
- Keyboards
- Speakers
- Other parts as defined by DIGITAL as CRUs

The DIGITAL CRU process provides for overnight shipment of the part directly to the customer site. The Service provider gives the customer instructions for installing the replacement unit and for returning the defective part. Customers are billed for the specified part if they fail to return the part to DIGITAL within ten days of the replacement unit shipment.

In the following troubleshooting tables, “CRU Process” means that when a process is determined to be broken, the Service provider should use the previously-described CRU process.



NOTE: The following troubleshooting suggestions are not in any specific order. They are merely a list of possible problems and solutions.

Workstation Troubleshooting

Problem	Possible Cause	Action
No response when the workstation is turned on.	Workstation is not plugged in.	Turn off the workstation, plug it in, and then turn it back on again.
	No power at the wall outlet.	Use another wall outlet.
	Main logic board failure.	Replace the main logic board.
	Main logic board jumpers/switches incorrectly set.	Set all appropriate jumpers/switches (Refer to Chapter 6).
	CPU has failed.	Replace the CPU.
	Power supply has failed.	Replace the power supply.
Power is on, screen is on, but the workstation does not respond.	Voltage select switch is set incorrectly.	Make sure the setting on the back of the workstation matches the country's voltage requirements. Refer to the on-line <i>Quick Setup Guide</i> for more information.
	Keyboard not connected, mouse not connected, or both might be in the wrong port.	Connect the keyboard and/or mouse. If already connected, confirm that each device is in the appropriate port.

continued

Troubleshooting

Problem	Possible Cause	Action
Power is on, but there is no screen display.	Brightness and contrast controls are not correctly set.	Adjust the brightness and contrast controls.
	The monitor-off timer has shut the monitor off.	Press [Shift] to reactivate monitor.
	Monitor is off.	Turn on the monitor.
	Monitor cable is incorrectly installed.	Check all monitor connections.
	Incorrect video drivers installed.	Install the correct video drivers.
	Video controller has failed.	Replace the video expansion board.
	Monitor has failed.	To ensure the problem is a monitor failure, if possible, try another monitor. If the new monitor fails to operate, follow the CRU Process to replace the monitor.

continued

Troubleshooting

Problem	Possible Cause	Action
Workstation operates incorrectly after installing an optional expansion board.	Expansion board installed incorrectly.	Remove the expansion board and reinstall.
	Did not run the ISA Configuration Utility (ICU) to configure a non-Plug and Play expansion board before installation.	Run the ICU to properly configure expansion board and then reboot the workstation. Refer to any supplied ICU and Windows NT Workstation documentation.
	Note: Plug and Play expansion boards are automatically configured.	
Workstation operates incorrectly after installing optional SIMMs.	Expansion board has failed.	Remove expansion board and reboot. If workstation boots without errors, replace expansion board.
	SIMMs installed incorrectly.	Remove SIMMs and reinstall.
	SIMMs have failed.	Remove SIMMs and reinstall. Make sure two banks are filled at a time with the correct SIMM size, speed, and type. Refer to the on-line System Reference manual for more information. Replace SIMMs.

continued

Troubleshooting

Problem	Possible Cause	Action
Workstation fails to retain setup information.	Workstation battery has failed.	Replace workstation battery.
	CMOS power switch (SW1-7) set to "Discharge."	Set CMOS power switch to "Normal." (Refer to Chapter 6).
Workstation displays HIMEM.SYS errors.	Unstable memory at the specified address.	Replace faulty SIMM(s).
Workstation displays a System Error F002 message	Faulty hardware.	Run the supplied diagnostic software to identify the faulty hardware. Replace the faulty hardware.

continued

Troubleshooting

Problem	Possible Cause	Action
"Couldn't Find NTLDR"	NTLDR file is missing from the root directory of the hard disk drive.	<p>Copy the NTLDR file to the hard disk drive's root directory.</p> <p>If using the supplied Windows NT Workstation CD-ROM disc, make the CD-ROM the current drive and then type:</p> <pre>copy\i386\ntldr c:\</pre> <p>at the command line prompt.</p> <p>If using the supplied Windows NT Workstation Setup disks, insert Setup Disk #2 into the diskette drive and then type:</p> <pre>expand ntldr.\$ C:\ntldr</pre> <p>at the command line prompt.</p>
"Error 000001E"	The hard disk drive might have corrupted system files.	<p>Run chkdsk on the hard disk drive to correct any corrupted files. Also make sure the hardware is on the supplied <i>Microsoft Windows NT Hardware Compatibility List</i>.</p> <p>If the problem still exists, replace the hard disk drive.</p>

continued

Problem	Possible Cause	Action
"Error 0x00000069 or 0x00000067"	Windows NT Workstation unable to communicate with the workstation's hard disk drive controller.	<p>Using the BIOS Setup utility, slow down the DMA transfer rate of the controller.</p> <p>Make sure both ends of the SCSI bus are terminated.</p> <p>Make sure there are no IRQ or memory address conflicts.</p> <p>Make sure NTDETECT.COM is in the root directory of the boot drive partition.</p> <p>Make sure there are no missing Windows NT Workstation system files.</p> <p>If the problem still exists, replace the main logic board.</p>
"NMI Hardware Error"	Faulty hardware.	<p>Make sure all main logic board SIMMs, processor, VRM, video memory, and expansion board connectors are clean and properly seated in their respective sockets.</p> <p>Run the supplied diagnostic software to identify the faulty hardware. Replace any faulty hardware.</p>
Services or subsystems do not start properly	Improper configuration, files missing or files not installed.	<p>Use the <i>Services</i> or <i>Devices</i> icons in the <i>Control Panel</i> menu to check for status. Also, check the system log in the <i>Event Viewer</i> for entries relating to the problem.</p> <p>If the problem still exists, reinstall the operating system.</p>

continued

Troubleshooting

Problem	Possible Cause	Action
Workstation does not boot from an IDE hard disk drive.	IDE drive type incorrect.	Run the BIOS Setup utility to identify the correct drive type. See drive type label on drive or consult drive documentation.
	Loose cables.	Secure all cable connections.
	Onboard IDE interface disabled.	Run the BIOS Setup utility and set the Local Bus IDE Adapter to "Enabled."
	Hard disk boot sector is missing.	Repartition and reformat the hard disk drive. Caution: This procedure erases what is currently on the hard disk drive. You might want to try repairing the hard disk drive using a disk drive repair utility. Disk drive repair utilities can be purchased from the local software supplier. If you do repartition and reformat the hard disk drive, proceed as follows for Windows NT Workstation. Boot from a DOS diskette then enter the following commands: c : cd \dos fdisk Follow the instructions on the monitor screen to create a new hard disk boot sector.
	There might be a boot sector virus.	Run anti-virus software.

continued

Problem	Possible Cause	Action
Workstation does not boot from an IDE hard disk drive.	IDE hard disk is connected to the wrong IDE connector.	Connect the boot disk to the inner IDE connector on the main logic board.
	Operating system software is not installed on the IDE hard disk drive.	Install the appropriate operating system.
	IDE hard disk drive is not correctly formatted or the requested partition does not exist.	Format the IDE hard disk drive or partition the IDE hard disk drive using the supplied operating system software.
	There is no software on the requested partition.	Install software on the requested partition.
	IDE hard disk drive jumpers incorrectly set.	Refer to the supplied IDE hard disk drive kit installation instructions.
	IDE hard disk drive has failed.	Replace the IDE hard disk drive.
	IDE hard disk drive ribbon cable has failed.	Replace the ribbon cable.
IDE controller has failed.	Replace the main logic board.	

continued

Troubleshooting

Problem	Possible Cause	Action
Workstation does not recognize an internal or external SCSI device.	SCSI device jumpers incorrectly set.	Refer to the supplied SCSI device kit installation instructions.
	SCSI ID conflicts.	Refer to the supplied SCSI device kit installation instructions on setting SCSI IDs.
	Terminating resistors not removed from the SCSI device.	Remove terminating resistors. Refer to the supplied kit installation instructions.
	SCSI option not enabled in BIOS Setup utility.	Run the BIOS Setup utility and enable SCSI option.
	SCSI cable not terminated.	Terminate each end of the SCSI cable.
	SCSI device not plugged in.	Check power and SCSI cables.
	Loose cable connectors.	Secure all cable connections.

continued

Problem	Possible Cause	Action
Workstation does not recognize an internal or external SCSI device.	Hard disk boot sector is missing.	<p>Repartition and reformat the hard disk drive.</p> <p>Caution: This procedure erases what is currently on the hard disk drive.</p> <p>You might want to try repairing the hard disk drive using a disk drive repair utility. Disk drive repair utilities can be purchased from the local software supplier.</p> <p>If you do repartition and reformat the hard disk drive, proceed as follows for Windows NT Workstation.</p> <p>Boot from a DOS diskette then enter the following commands:</p> <pre>c : cd \dos fdisk</pre> <p>Follow the instructions on the monitor screen to create a new hard disk boot sector.</p> <p>Run anti-virus software.</p>
	There might be a boot sector virus.	Run anti-virus software.
	Loose cable connectors.	Secure all cable connections.
	SCSI adapter has failed.	Replace the SCSI adapter.
	SCSI ribbon cable has failed.	Replace the ribbon cable.
	SCSI device has failed.	Replace the SCSI device.

continued

Troubleshooting

Problem	Possible Cause	Action
Workstation does not boot from an internal SCSI hard disk drive.	Workstation not configured for SCSI hard disk drive operation.	Run the BIOS Setup utility and set the IDE controller option to "Disabled." This disables the onboard IDE interface. Note: If you have both IDE and SCSI hard disk drives installed, the workstation uses the IDE hard disk drive as the boot device.
	Operating system software is not installed on the SCSI hard disk drive.	Install the appropriate operating system.
	Requested partition does not exist.	Partition the SCSI hard disk drive and then reload the operating software.
	SCSI adapter has failed.	Replace the SCSI adapter.
	SCSI ribbon cable has failed.	Replace the ribbon cable.
	SCSI hard disk drive has failed.	Replace the SCSI hard disk drive.

continued

Problem	Possible Cause	Action
Workstation does not boot from a target diskette drive.	Onboard diskette controller disabled.	Run the BIOS Setup utility and set the diskette controller option to "Enabled."
	Diskette drive not enabled.	Run the BIOS Setup utility to enable the diskette drive
	BIOS Setup diskette write option enabled.	Enter the user password. If a supervisor password is required, see the system supervisor or system manager.
	Incorrect diskette drive type.	Run the BIOS Setup utility and select the correct drive type.
	Diskette boot option disabled.	Run the BIOS Setup utility and set the proper boot sequence.
	Diskette might not be bootable.	Use a bootable diskette.
	Diskette does not contain start-up files.	Insert a diskette with the correct start-up files.
	Diskette drive is empty.	Insert a diskette that contains an operating system.
	Diskette is worn or damaged.	Try another diskette.
	Loose cable connectors.	Secure all cable connections.
	Diskette access requires a supervisor password.	See the supervisor or system manager.
	Diskette access requires a user password.	Enter the user password.

continued

Troubleshooting

Problem	Possible Cause	Action
No response to keyboard commands.	Keyboard is password protected.	Enter the keyboard password.
	Keyboard is not connected.	Power down the workstation and connect the keyboard.
	Keyboard is connected to the mouse port.	Power down the workstation and connect the keyboard to the keyboard port.
	Workstation operation halted.	Reboot workstation.
	Keyboard has failed.	To ensure the problem is a keyboard failure, if possible, try another keyboard. If the new keyboard fails to operate, follow the CRU Process to replace the keyboard.
Keyboard controller has failed.	Replace the main logic board.	

continued

Problem	Possible Cause	Action
Keyboard keys type incorrectly.	Incorrect language selected.	Select the correct language.
	Keyboard has failed.	To ensure the problem is a keyboard failure, if possible, try another keyboard. If the new keyboard fails to operate, follow the CRU Process to replace the keyboard.
No response to mouse activity.	Mouse is not connected.	Power down the workstation and connect the mouse.
	Mouse is connected to the keyboard port.	Power down the workstation and connect the mouse to the mouse port.
	Workstation operation halted.	Reboot workstation.
	Mouse driver not installed.	Install the appropriate mouse driver. Refer to the on-line System Software manual.
	Onboard mouse controller disabled.	Run the BIOS Setup utility and set the mouse port option to "Enable."
	Mouse has failed.	To ensure the problem is a mouse failure, if possible, try another mouse. If the new mouse fails to operate, follow the CRU Process to replace the mouse.
	Mouse controller has failed.	Replace the main logic board.
Mouse sticks.	Dirty mouse ball.	Remove mouse ball and clean it.

Disk Drive Troubleshooting

Problem	Possible Cause	Action
IDE/SCSI hard disk drive cannot read or write information.	Incorrect disk drive jumper settings.	Refer to the supplied kit installation instructions.
	Loose or incorrectly installed cables.	Make sure all cables are correctly installed.
	IDE/SCSI hard disk drive is not correctly formatted or partitioned.	Format and partition as required using the supplied operating system.
	IDE drive type incorrect.	Run the BIOS Setup utility to identify the correct drive type.
	Onboard IDE interface disabled.	Run the BIOS Setup utility and set the Local Bus IDE Adapter to "Both."
	IDE/SCSI hard disk drive has failed.	Replace the hard disk drive.
	IDE/SCSI controller has failed.	Replace the main logic board (IDE) or the SCSI controller.
IDE/SCSI ribbon cable has failed.	Replace the ribbon cable.	

continued

Problem	Possible Cause	Action
Target diskette drive cannot read or write information.	Diskette is not formatted.	Format the diskette.
	Diskette is worn or damaged.	Try another diskette.
	Diskette is write-protected.	Slide the write-protect switch so the hole is not visible (3½-inch diskette) or uncover the write-protect notch (5¼-inch diskette).
	Diskette drive is empty.	Insert a diskette.
	Onboard diskette controller disabled.	Run the BIOS Setup utility and set the diskette controller option to "Enabled".
	Diskette write protection is enabled.	Run the BIOS Setup utility and set the diskette write protection to "Disabled."
	Loose cable connectors.	Secure all cable connections.
	Diskette drive has failed.	Replace the diskette drive.
	Diskette drive controller has failed.	Replace the main logic board.
Target diskette does not format diskettes.	Diskette drive ribbon cable has failed.	Replace the ribbon cable.
	Diskette access requires supervisor password.	Reboot workstation and enter the supervisor password. Afterwards, run BIOS Setup utility and set "Diskette Access" option to "User."
	Diskette write protection is enabled.	Run the BIOS Setup utility and set the diskette write protection to "Disabled."
	Diskette drive has failed.	Replace the diskette drive.

Monitor Troubleshooting

Problem	Possible Cause	Action
Monitor power indicator is not on.	Monitor is turned off.	Turn on the monitor.
	Power cord is not connected.	Connect the power cord to the workstation.
	No power at wall outlet.	Use another outlet.
	The monitor-off timer shut off the monitor.	Press [Shift] to reactivate monitor.
	Monitor has failed.	To ensure the problem is a monitor failure, if possible, try another monitor. If the new monitor fails to operate, follow the CRU Process to replace the monitor.
	Video controller has failed.	Replace the video expansion board.
No screen display.	Power indicator is defective.	Follow the CRU Process to replace the monitor.
	Configuration error.	Run the BIOS Setup utility to configure the workstation for correct video operation.
	Monitor brightness and contrast controls are incorrectly set.	Adjust the monitor brightness and contrast controls.
	The monitor-off timer shut off the monitor.	Press [Shift] to reactivate monitor.
	Wrong Windows driver loaded.	Load the correct video driver.

continued

Troubleshooting

Problem	Possible Cause	Action
No monitor display while loading Windows video drivers.	Monitor type incorrectly set.	Set the correct monitor type using the appropriate utility.
Distorted, rolling, or flickering screen display, or wrong/uneven color.	Monitor incorrectly adjusted.	Adjust accordingly.
	Monitor signal cable incorrectly installed.	Straighten any bent connector pins and then reconnect.
Color monitor displaying monochrome.	Workstation was turned on before the monitor was turned on.	Turn off the workstation, turn on the monitor, then turn the workstation back on.
Monitor fails to switch to high-resolution mode.	Appropriate high-resolution video drivers are not installed or incorrectly installed.	Correctly install all appropriate high-resolution video drivers. Refer to the documentation supplied with the monitor.
Monitor display disappears.	Screen display sized incorrectly.	Correctly size screen display.

Audio Troubleshooting

Problem	Possible Cause	Action
Audio does not work.	Sound, MIDI, mixer drivers not installed.	Check the error messages for the necessary drivers. In Windows Control Panel, select "Drivers", then "Add" and install the necessary driver(s).
	Address contention. Two or more devices might be trying to access the same address.	Check IRQ, I/O address, and DMA settings in Windows NT Workstation or BIOS Setup. Change settings as required.
	Cables loose or not properly connected.	Make sure speaker and mic plugs are in correct jacks. Reconnect cables.
	Onboard audio controller disabled.	Run the BIOS Setup utility and set the Integrated Audio to "Enabled."
	Bad audio chip or sound card.	Replace the backplane circuit board or sound card.
	Main logic board has failed.	Replace the main logic board.

continued

Problem	Possible Cause	Action
External speakers do not work.	Speakers not connected or improperly connected.	Properly connect the speakers. Refer to the <i>System Reference</i> manual for more information.
	Speaker batteries or ac adapter have failed.	Replace speaker batteries or ac adapter. Refer to the documentation that came with the speakers.
	Speakers have failed.	To ensure the problem is an external speaker failure, if possible, try another set of speakers. If the new speakers fail to operate, follow the CRU Process to replace the external speakers.
Microphone does not work.	Microphone not connected or improperly connected.	Properly connect the microphone. Refer to the <i>System Reference</i> manual for more information.
	Microphone has failed.	To ensure the problem is a microphone failure, if possible, try another microphone. If the new microphone fails to operate, follow the CRU Process to replace the microphone.
Headphone set do not work.	Headphone set not connected or improperly connected.	Properly connect the headphones. Refer to the <i>System Reference</i> manual for more information.
	Headphone set has failed.	To ensure the problem is a headphone set failure, if possible, try another headphone set. If the new headphone set fails to operate, follow the CRU Process to replace the headphone set.

CD-ROM Troubleshooting

Problem	Possible Cause	Action
Cannot access the CD-ROM drive. Error message reading drive x.	Device drivers not installed.	Install correct device drivers.
	No disk in the CD-ROM drive.	Insert a disk.
	CD-ROM drive tray is open.	Close the tray.
	Onboard IDE interface disabled (if IDE CD-ROM)	Run the BIOS Setup utility and set the Local Bus IDE Adapter to "Enabled."
	CD-ROM has failed. Cables have failed.	Replace the CD-ROM. Replace defective cables.
Power is on but CD-ROM drive indicator shows no activity.	No CD-ROM disc or CD-ROM drive tray is open.	Insert a disk and close the tray.
	Check cable connections.	Make sure cables are correctly connected.
	CD-ROM has failed.	Replace the CD-ROM.
	Cables have failed.	Replace defective cables.
CD-ROM disc is spinning but CD-ROM drive is idle.	Application software not running.	Run application software.

Network Interface Troubleshooting

Problem	Possible Cause	Action
Power is on, LAN address is installed on workstation; system hangs.	Incorrect software installed or software installed incorrectly.	Contact system administrator or network coordinator.
Workstation is on, no keyboard response.	Incorrect IRQ.	Check BIOS setup and Windows NT Workstation settings.
Network doesn't start.	Network cable not connected or is loose.	Connect cable. Also, make sure no more than one ethernet cable is connected at one time.
	Conflict exists with another device adapter; incorrect IRQ setting.	Check BIOS setup or Windows NT Workstation settings.
	Network cable has failed.	Contact the system administrator or network coordinator.
	Onboard network controller disabled.	Run the BIOS Setup utility and set Integrated Ethernet to "Enabled."
	Onboard network controller has failed.	Replace the backplane.

Error Messages

This section lists workstation messages that might be seen or heard when turning on power. The workstation messages are grouped as follows:

- POST and boot workstation messages
- POST execution messages
- Beep codes

POST Messages

The POST displays messages to alert the user to errors in hardware, software, and firmware or to provide operating information about the workstation.

Each time the POST displays a message on the screen, the workstation's speaker beeps twice. If an error occurs before the monitor is initialized, specific beep codes sound to alert the user to a problem. The following table lists a general grouping of workstation messages. In addition, each message is accompanied by text describing the message and in most cases, a recommended solution to the problem.



NOTE: Italics indicate variable parts of a message such as memory addresses, hexadecimal values, and so on. These messages can differ at each occurrence.

POST and Boot Messages

Message	Description/Solution
Asynchronous Synchronous Burst Synchronous Pipeline Burst Passed	Where <i>nnnn</i> is the amount of workstation cache (in kilobytes) that tested successfully.
Diskette drive A error	Run the BIOS Setup utility. Check all connections. If the problem persists, replace the diskette drive.
Diskette drive B error	
Entering SETUP	BIOS Setup utility runs.
Extended RAM Failed at offset: <i>nnnn</i>	Extended memory failed or configured incorrectly. Make sure SIMMs are installed correctly (Refer to on-line <i>System Reference</i> manual). If the problem persists, replace any faulty SIMMs. Run the BIOS Setup utility and restore all settings to original values.
Extended RAM Passed	Where <i>nnnn</i> is the amount of extended memory (in kilobytes) that tested successfully.
Failing Bits: <i>nnnn</i>	<i>nnnn</i> is a map of the bits at the RAM address which failed the memory test. Run the BIOS Setup utility and restore all to original values. If the problem persists, replace any faulty SIMMs.
Fixed Disk 0 Failure	Run the BIOS Setup utility. Check all connections. If the problem persists, replace the hard disk drive.
Fixed Disk 1 Failure	Fixed disk controller failure

continued

Troubleshooting

Message	Description/Solution
Incorrect Drive A type - run SETUP	Diskette drive A and/or B not correctly identified in the BIOS Setup utility.
Incorrect Drive B type - run SETUP	Run the BIOS Setup utility and properly identify diskette drive A and/or B.
Invalid NVRAM media type	NVRAM access failed. Run the BIOS Setup utility and restore all settings to original values. If the problem persists, replace the main logic board.
Keyboard controller error	Check the keyboard connection. If the connection is secure, the keyboard or keyboard controller might have failed. If the problem persists, replace the main logic board or keyboard.
Keyboard error	
Keyboard locked - Unlock key switch	
Monitor type does not match CMOS - Run SETUP	Run the BIOS Setup utility and set the correct monitor type.
Operating system not found	The operating system cannot be found on drive A or drive C. Run the BIOS Setup utility and correctly identify drive A or drive C. Correctly install the operating system. Refer to the supplied operating system documentation.
Press <F1> to resume, <F2> to Setup	This message appears after any recoverable error message. Press [F1] to reboot or [F2] to enter the BIOS Setup utility to make any necessary changes.
Real time clock error	Battery failed BIOS test. Replace battery and then run the BIOS Setup utility to restore previous configuration information.

continued

Message	Description/Solution
Shadow RAM Failed at offset: <i>nnnn</i>	Shadow RAM failed. Run the BIOS Setup utility and disable failed shadow memory region.
<i>nnnn</i> Shadow RAM passed	Where <i>nnnn</i> is the amount of shadow RAM (in kilobytes) that tested successfully.
RTC is dead - Replace and run SETUP	Replace the RTC and then run the BIOS Setup utility to restore previous configuration information.
System BIOS shadowed	This indicates that the workstation's BIOS was successfully copied to shadow RAM.
System cache error - Cache disabled	RAM cache failed. Run the BIOS Setup utility and restore all settings to original values. If the problem persists, replace faulty processor.
System CMOS checksum bad - run SETUP	Correct the address conflict using the BIOS Setup utility. If the problem persists, replace the main logic board.
System RAM failed at offset: <i>nnnn</i>	System RAM failed. Run the BIOS Setup utility and restore all settings to original values. If the problem persists, replace any faulty SIMMs.
<i>nnnn</i> System RAM passed	Where <i>nnnn</i> is the amount of system RAM (in kilobytes) that tested successfully.
System timer error	The workstation's timer test failed. Run the BIOS Setup utility and restore all settings to original values. If the problem persists, replace the main logic board.
UMB upper limit segment address: <i>nnnn</i>	Displays the address of the upper limit of UMB. This indicates the released segments of the BIOS that can be reclaimed by a virtual memory manager.
Video BIOS shadowed	This indicates that the workstation's video BIOS was successfully copied to shadow RAM.

POST Execution Messages

The following messages appear at the bottom of the screen during POST execution.

Message	Description
230	Unexpected interrupts test
220	Shadow ROMs
210	Test RAM between 512K and 640K
200	Extended memory test
190	Set cache registers
180	Cache configuration
170	Real-time clock test
160	Keyboard test
150	Initial hardware interrupt
140	Co-processor test
130	Serial ports test
120	Parallel ports test
110	Initiate onboard SIO
100	Mouse test
95	CD-ROM initialize
90	Testing diskette drives
80	Testing hard disk drives
30	Setup power management
20	Enable IRQs
10	Setting time of day

Beep Codes

When POST finds an error and cannot display a message, the workstation's speaker emits a series of beeps to indicate the error and places a value in I/O port 80h. During POST, if the video configuration fails or if an external ROM module fails a checksum test, then the workstation beeps three times (one long beep, and two short beeps).

The following table lists other fatal errors and their associated beep codes. Each code represents the number of short beeps that are grouped together. Fatal errors (errors that lock up the workstation) are generally the result of a failed main logic board or some other add-on component (SIMM, BIOS, workstation battery, etc.).

Beep Code	Error
1	One short beep before boot
1-2	Search for option ROMs
1-2-2-3	BIOS ROM checksum
1-3-1-1	Test DRAM refresh
1-3-1-3	Test keyboard controller
1-3-4-1	Test 512K base address lines
1-3-4-3	Test 512K base memory
1-4-1-1	Test memory bus
2-1-2-3	Check ROM copyright notice
2-2-3-1	Test for unexpected interrupts

Troubleshooting

Parts Replacement **5**

Introduction

The following sections list the Illustrated Parts Breakdown (IPB) part numbers and related replacement procedures.

Parts Replacement

DIGITAL Personal Workstation IPB List

Figure Legend	Spare Part Number	Exchangeable Part Number	Description
1	54-25328-01		Main logic board, with VGA
2	54-25092-BA 20-47405-D2 54-25092-DA		64MB SDRAM DIMM 8 M x 72 unbuffered 32MB SDRAM DIMM 4 M x 72 unbuffered 128MB DIMM
3	54-25324-01 70-32729-01 70-32729-02		MOD, CPU card CPU assy, 266 Pentium II, 512K, ECC, W CPU assy, 300 Pentium II, 512K, ECC, W
4	54-25316-01		MOD, VRM, 8.1 DC-DC converter (slim)
5	30-47661-04		Power supply, 300 W
6	54-25432-01		MOD, rear panel, audio & MIDI
7	54-25151-03		High performance 32BIT PCI 3-D graphic card
8	54-25326-01 54-25326-02		BNC LAN card AUI card
9	74-50747-01		Option filler plate
10	12-41474-05		Battery, 3 VDC lithium, CR2032

⁽¹⁾ N/I = Not Illustrated

Parts Replacement

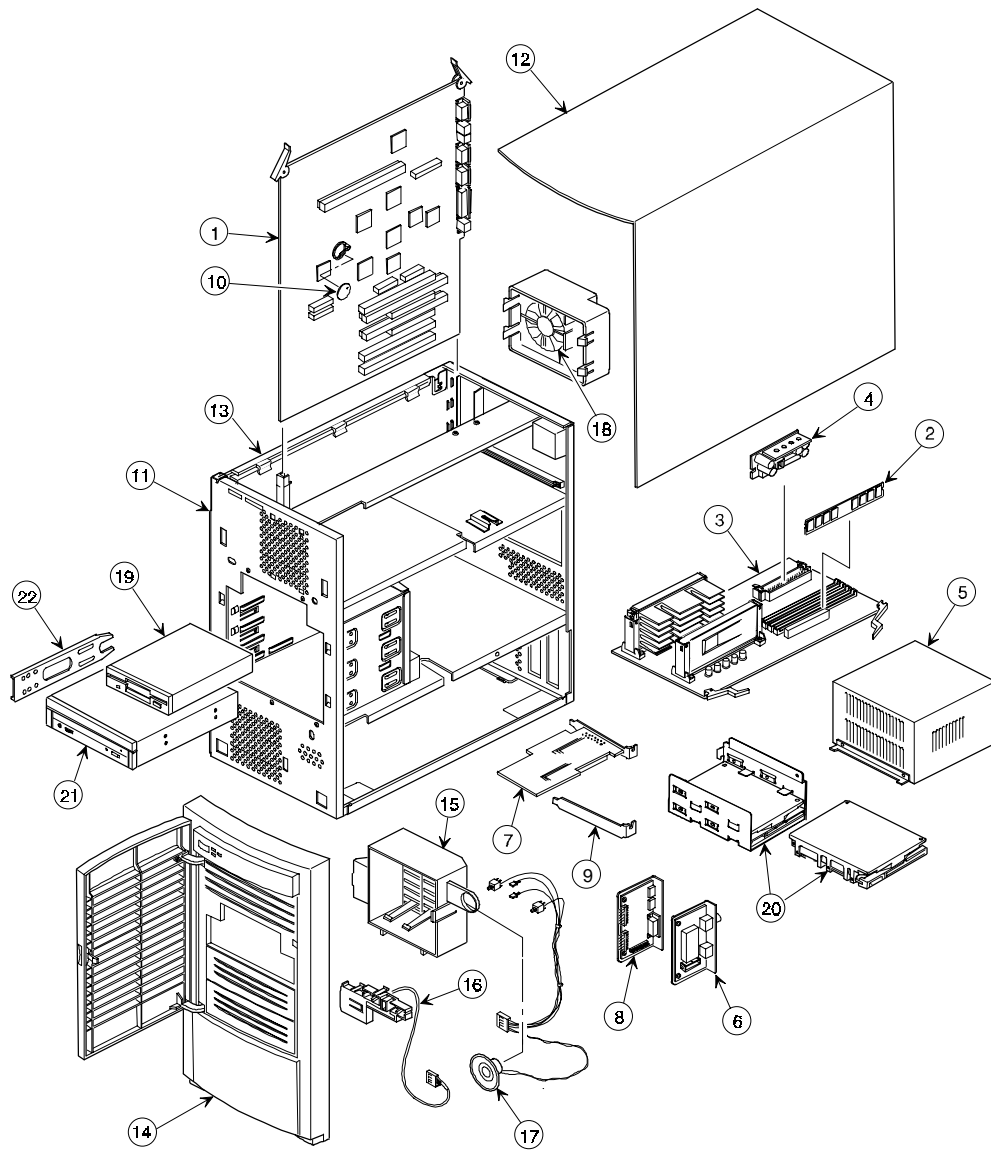

DIGITAL PERSONAL WORKSTATION

DEC01460

Figure 5-1. DIGITAL Personal Workstation

Parts Replacement

Enclosure

Figure Legend	Orderable Spare Part	Exchangeable Spare Part	Description
11	70-32678-07		Enclosure
12	70-33124-03		Cover, L-shape
13	74-33125-03		Side panel, left
14	70-33006-01		Bezel, with filler panels
15	74-50755-01		Guide, option cards
16	74-50863-01		Control panel
17	17-04372-04		Speaker/LED, switch wire harness assembly
18	74-51236-01		Fan mount, universal
N/I ⁽¹⁾	90-17008-02		Screw, captive 6-32
N/I ⁽¹⁾	74-51171-01		3.5" FDD sheild, blank
N/I ⁽¹⁾	74-50914-01		Bezel, 3.5" FDD blank
N/I ⁽¹⁾	74-51239-01		Filler, vent cover, bottom front
N/I ⁽¹⁾	74-51361-01		Vent cover, top front
N/I ⁽¹⁾	74-51362-01		Vent cover, top rear
N/I ⁽¹⁾	74-48816-01		Medallion, front panel (DEC logo)
N/I ⁽¹⁾	74-50804-01		Rubber feet
N/I ⁽¹⁾	74-50911-01		Bracket, I/O expansion
N/I ⁽¹⁾	54-24526-01		MOD, front panel audio board and wire harness

⁽¹⁾ N/I = Not Illustrated

Storage Devices

Figure Legend	Orderable Spare Part	Exchangeable Spare Part	Description
19	PCXRJ-AD		1.44MB floppy disk drive frost white flat bezel
20	RZICC-BA PCXRA-AT PCXRA-AU RZ1BC-BA RZ1DB-BA		4.3GB, 1", 7200 rpm Ultra SCSI Hard Disk, S 4.3GB UMDA IDE Hard Disk, Quantum 6.4GB UDMA IDE HDD 2.1GB UW SCSI HDD 9.1GB UW SCSI HDD
21	PCXRN-AN PCXRN-AM		24X max IDE CD-ROM, TEAC 24X max IDE CD-ROM, Toshiba XM (acceptable substitute)
22	79-49365-01		Holder, drive rail (comes with enclosure)
N/I ⁽¹⁾	90-11334-01 90-08020-01		Screw, machine 6-32 pan .187 x XRCS (HDD) Screw, machine 6-32 pan .187 x XRCS (HDD) (acceptable substitute)
N/I ⁽¹⁾	90-40217-01 90-10961-01		Screw, machine M3 pan 5 mm x XRCS CSZ (FDD) Screw, machine M3 pan 5 mm x XRCS CSZ (FDD) (acceptable substitute)
N/I ⁽¹⁾	74-44337-02 74-46480-01		Expansion bracket 5.25" to 3.5" Expansion bracket 5.25" to 3.5" (acceptable substitute)

⁽¹⁾ N/I = Not Illustrated

Parts Replacement

SCSI and Video Adapter Cards

Figure Legend	Orderable Spare Part	Exchangeable Spare Part	Description
N/I ⁽¹⁾	30-46729-02		Adaptec 2940UW PCI SCSI adapter
N/I ⁽¹⁾	30-48152-01		Matrox millenium II graphics card

(1) N/I = Not Illustrated

CPU Retention Assembly

Spare Part Number	Exchangeable Part Number	Description
12-45765-01		Retention mechanism assy
12-45806-01		Stud, bridge assembly

Cables and Terminator

Orderable Spare Part	Exchangeable Spare Part	Description
17-03461-17		Cable assy, 40 cond., flat 28AWG, 415 mm
17-04331-03		Cable assy, flat, 16P IDC to 16P I
17-04550-03		Cable assy, flat, 68 cond., 30AWG, male
17-04696-01		Cable assy, flat, 34 pos, 460mm
70-31909-04		Cable assy, micro switch, 7.0 inches
17-04373-03		Wire harness assy, shield, UL2547
17-04372-01		Cable, control panel
17-04405-02		Cable, 16 pos, LAN 10
17-04278-02		Cable, audio, IDE CD-ROM
17-04405-07		AUI/BNC LAN cable
54-25302-02		MOD, CPU termination card

Parts Replacement

Miscellaneous

Orderable Spare Part	Exchangeable Spare Part	Description
30-43276-01		Headset labtec C-10
30-43275-01		Microphone goltron
30-46117-02		Mouse, 3-button, frost white, single pack
DE500-BA		10/100Base Ethernet adapter
12-21778-01 or 90-09538-02		Bumper for MLB
12-44211-01		Fan, tube axial 3.5" brishless D
12-45246-04		Fan, tube axial, 80 mm DC brushless
70-33077-01		Key-lock assy
12-45806-01		Stud, bridge assy

Service Procedures

The following sections provide detailed service instructions for DIGITAL Personal Workstations.



CAUTION: Static electricity collects on non-conductors such as paper, cloth, or plastic. A static discharge can be damaging even though you often cannot see or feel it. To prevent damage to circuit boards and/or components:

- Before touching any circuit board or component, touch the metal frame of the workstation to discharge any static electricity.
- Keep circuit boards and components away from non-conductors.

Recommended Tools

Have the following tools available:

- Multimeter (4½-inch digit)
- Phillips screwdriver
- Antistatic wrist strap (recommended, but not required)

Other Materials Needed

Cleaning agent should be an all purpose cleaner that is used in-house.

Special Tools Required

None.

Parts Replacement

Remedial Diagnostic Test Software

Supplier information:

AMI Diagnostics
6145-F Northbelt Parkway
Norcross, GA 30071, U.S.A.
Voice: 1-770-246-8600
FAX: 1-770-246-8791
Support: 1-770-246-8645
Internet: <http://www.megatrends.com>

Virus Software Information

F-PROT, Virus Detection and Cleanup Software, latest version.

Supplier information:

North America, South America, Australia and New Zealand
Command software Systems Inc.
Tel: +1-407-575 3200
FAX: 1-407-575-3026

BIOS Version Information

For access directly to the software library, use the address:

<http://www.windows.digital.com>

Disconnecting External Devices and Power

1. Turn off power to all external devices connected to the workstation.
2. Turn the workstation off.
3. Disconnect power from the wall outlet.
4. Disconnect the power cord and monitor cord.

Removing the Workstation's Outside Cover

1. Turn off power to all external devices connected to the workstation.
2. Turn the workstation off.
3. Unplug the workstation and monitor power cord from the wall outlet.
4. For workstation's without a chassis lock, go to step 4a. For workstations with a chassis lock, go to step 4b.
 - a. Release the outside cover by loosening the rear-panel thumbscrews.
 - b. Unlock the outside cover by inserting the key and turning it counter clockwise. Loosen the other two rear-panel thumbscrews.
5. Slide the outside cover backwards and then carefully lift it away from the chassis.



SHOCK OR STATIC SENSITIVE: Static electricity collects on non-conductors such as paper, cloth, or plastic. A static discharge can be damaging even though you often cannot see or feel it. To prevent damage to circuit boards and/or components:

- Before touching any circuit board or component, touch the metal frame of the workstation to discharge any static electricity.
- Keep circuit boards and components away from non-conductors.

Parts Replacement

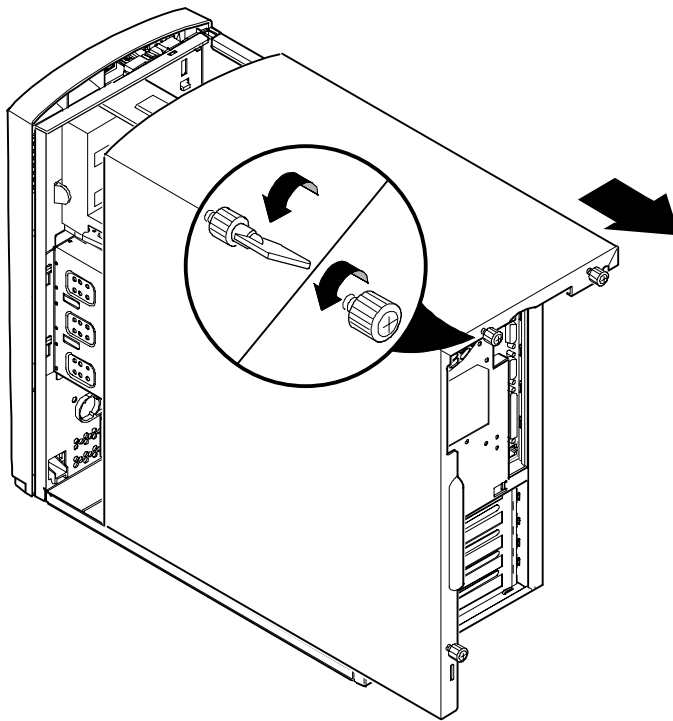

DEC01300-2

Figure 5-2. Removing the Outside Cover

Workstation Components

The following sections identify the DIGITAL Personal Workstation components including: main logic components, main logic board connectors (rear panel), backplane components, expansion slots, main logic board jumper locations, and memory configurations.

Main Logic Board Components

Figure Legend	Component
A	Workstation battery
B	Video memory
C	Permedia P2 graphics/video accelerator
D	Dip switch
E	SCSI controller
F	Workstation flash BIOS
G	Super I/O controller
H	DIGITAL 21143 PCI Ethernet controller
I	Wave table
J	Crystal CS4237 audio controller
K	Intel PIIX4 ISA/IDE/USB controller

Parts Replacement

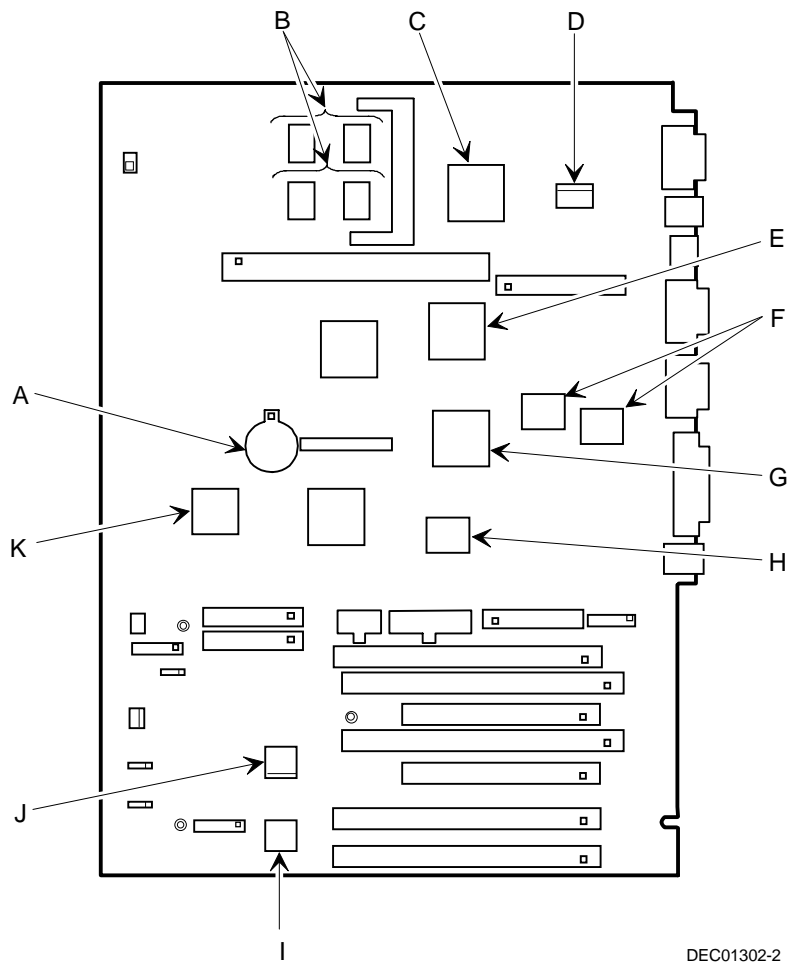

DEC01302-2

Figure 5-3. Main Logic Board Components

Main Logic Board Connectors (Rear Panel)

Figure Legend	Connector
A	Video port
B	Keyboard and mouse ports
C	Two USB ports
D	Two serial ports
E	Parallel port
F	10/100Base-T network port



NOTE: Your workstation's video port is located on the PCI video expansion board that was factory installed into your workstation.

Your workstation's external SCSI port is located on the PCI SCSI adapter that was factory installed into your workstation.

Parts Replacement

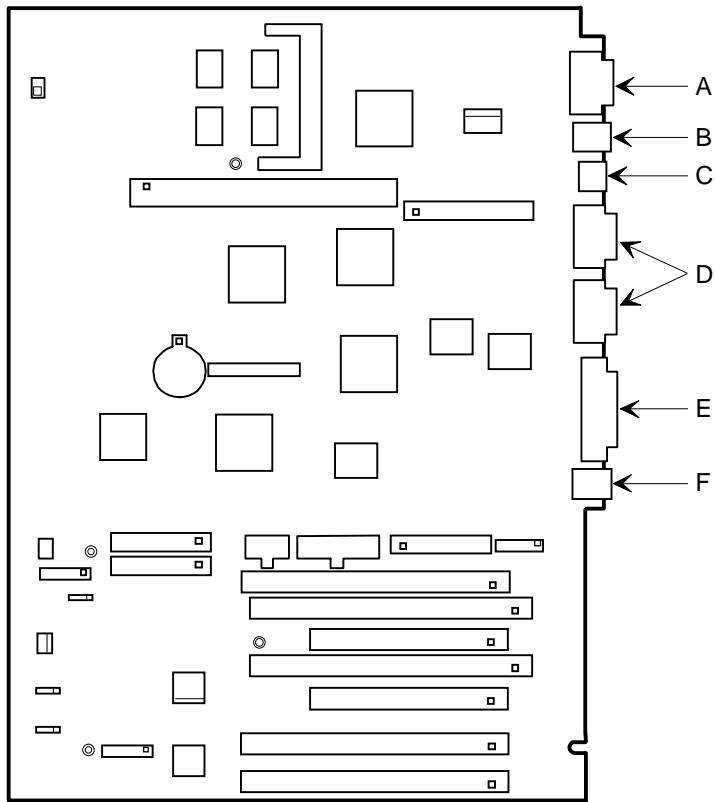

DEC01302-3

Figure 5-4. Main Logic Board Components (Rear Panel)

Main Logic Board Jumper and Switch Settings



STATIC SENSITIVE: Static electricity collects on non-conductors such as paper, cloth, or plastic. A static discharge can be damaging even though you often cannot see or feel it. To prevent damage to the main logic board:

- Touch the metal frame of your workstation to discharge any static electricity.

Feature	Function	Setting	Description
Clear password	Enable	SW1-1, ON	If you forget your password, set this switch to ON and then restart the workstation.
	Disable(1)	SW1-1, OFF(1)	
Recovery mode	Enable	SW1-2, ON	If your flash BIOS upgrade failed, set this switch to ON so you can boot your workstation from a Crisis Recovery diskette. Refer to the README.TXT provided with the flash BIOS upgrade.
	Disable(1)	SW1-2, OFF(1)	
Clear CMOS	Enable	SW1-3, ON	Clears CMOS of all BIOS setup information. Use the Enable setting when your workstation will not boot, and BIOS setup cannot be accessed due to configuration data corruption. This switch must be set back to Disable before rebooting your workstation.
	Disable(1)	SW1-3, OFF(1)	
Flash enable	Enable	SW1-4, ON	When disabled, prevents corruption or reprogramming of BIOS boot block data. Updating the BIOS boot block data is normally reserved for factory use only, unless instructed otherwise by your Service provider.
	Disable(1)	SW1-4, OFF(1)	

(1) Factory default

Parts Replacement

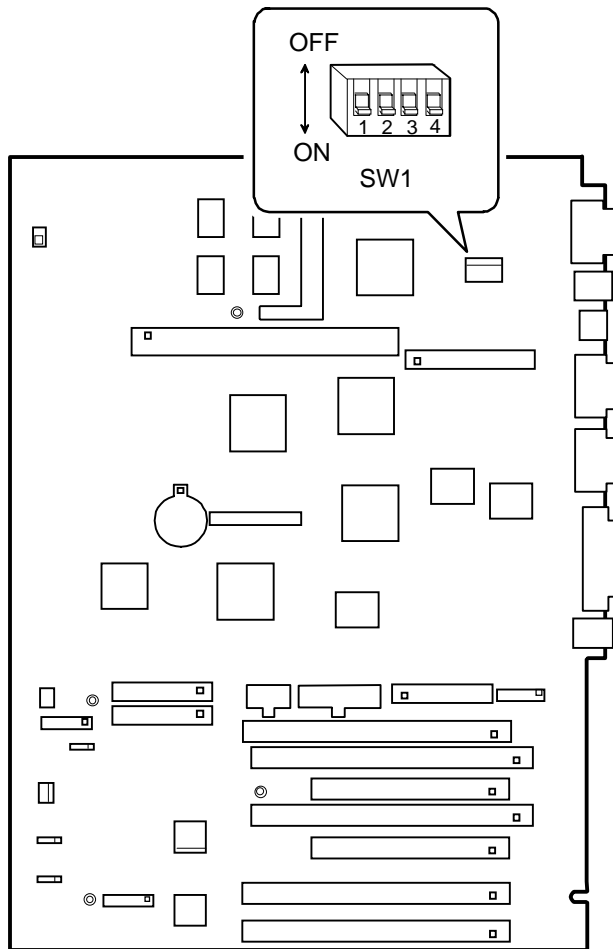

DEC01302-8

Figure 5-5. Main Logic Board Switch Locations

Pentium® II Processor Module Switch Settings

Description	Switch 1	Switch 2	Switch 3	Switch 4
266 MHz	OFF	ON	OFF	OFF
300 MHz(1)	OFF	ON	ON	OFF
333 MHz	ON	ON	OFF	OFF
366 MHz	ON	ON	ON	OFF
400 MHz	OFF	OFF	OFF	ON
433 MHz	OFF	OFF	ON	ON
466 MHz	ON	OFF	OFF	ON
500 MHz	ON	OFF	ON	ON
533 MHz	OFF	ON	OFF	ON

(1) Factory default
 OFF = switch up; ON = switch down

Parts Replacement

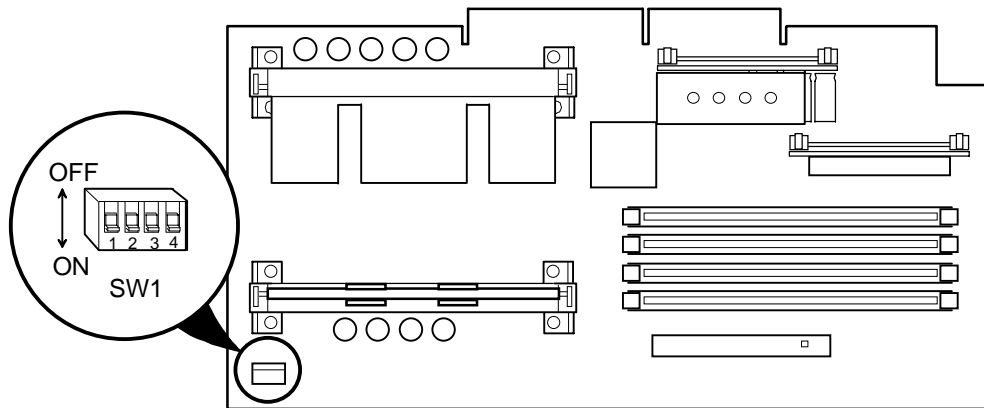

DEC01304-8

Figure 5-6. Pentium® II Processor Module Switch Locations

Adding Additional Workstation Memory

DIGITAL Personal Workstations come with at least 32 MB of workstation memory. DIGITAL Personal Workstations also contain four DIMM connectors. All four DIMM sockets (J18, J19, J20, and J21) accept single or dual sided DIMMs.

Install 168-pin DIMMs using 83 MHz (or faster), 64-bit SDRAMs, in 32 MB, 64 MB, and 128 MB memory module sizes, to expand workstation memory up to 512 MB.

Figure 5-7 shows the location of the four DIMM sockets,

Parts Replacement

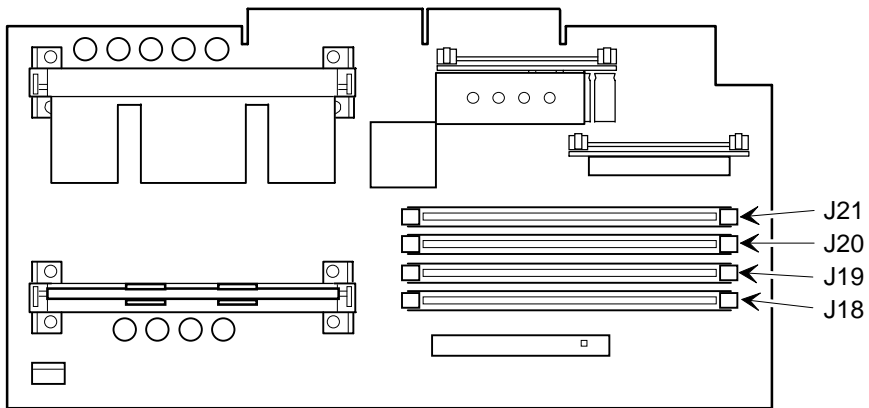

DEC01304-7

Figure 5-7. DIMM Socket Locations

Memory Configurations

Bank 0 (J18)	Bank 1 (J19)	Bank 2 (J20)	Bank 3 (J21)	Total Memory
32 MB				32 MB
64 MB				64 MB
64 MB	32 MB			96 MB
64 MB	64 MB			128 MB
64 MB	32 MB	32 MB		128 MB
64 MB	64 MB	64 MB		192 MB
64 MB	32 MB	32 MB	32 MB	160 MB
64 MB	64 MB	32 MB	32 MB	192 MB
64 MB	64 MB	64 MB	32 MB	224 MB
64 MB	64 MB	64 MB	64 MB	256 MB
128 MB				128 MB
128 MB	64 MB	32 MB		224 MB
128 MB	128 MB			256 MB
128 MB	128 MB	64 MB	32 MB	352 MB
128 MB	128 MB	128 MB		384 MB
128 MB	128 MB	128 MB	64 MB	448 MB
128 MB	128 MB	128 MB	128 MB	512 MB

Table does not list all possible configurations

Adding Video Memory

If the workstation came with an integrated Permedia P2 graphics/video accelerator, it includes 4 MB of SGRAM video memory on the main logic board. This can be upgraded to 8 MB by installing an optional 4 MB SGRAM daughter card on the main logic board. Figure 5-8 shows the location of the SGRAM socket on the main logic board.

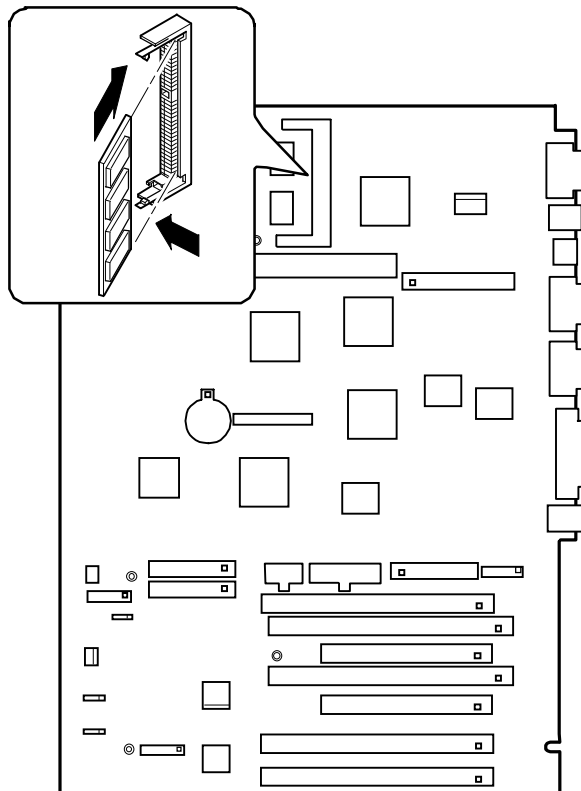

DEC01302-6

Figure 5-8. Video Memory Socket Location

DIGITAL PERSONAL WORKSTATION

Removing and Replacing Components

The following sections provide removal and replacement procedures for the following DIGITAL Personal Workstation components:

- Main logic board
- DIMMs
- Battery
- Processor
- VRM
- Terminator Module
- Expansion boards
- Power supply
- Control panel
- Fans
- 3½-inch mass storage devices
- 5¼-inch mass storage devices

Removing the Main Logic Board

1. Turn off your workstation and monitor.
2. Disconnect all external devices, ac power, and monitor power.
3. Remove the outside cover.
4. Disconnect all internal device cables and then tag them for identification.
5. Remove all expansion boards.
6. Remove the Pentium® II processor module.
7. Remove the four screws from the expansion board area of the main logic board.
8. Carefully slide the main logic board towards the top and out of the chassis.



NOTE: If replacing the main logic board, it may be necessary to move the processor and other components such as SIMMs to the new main logic board. The processor chip and heat sink assembly should be removed and reinstalled as a single assembly, there is no need to disassemble the processor and heat sink.



STATIC SENSITIVE: Static electricity collects on non-conductors such as paper, cloth, or plastic. A static discharge can be damaging even though you often cannot see or feel it. To prevent damage to the main logic board:

- Touch the metal frame of your workstation to discharge any static electricity.
- Keep the main logic board away from non-conductors.

Parts Replacement

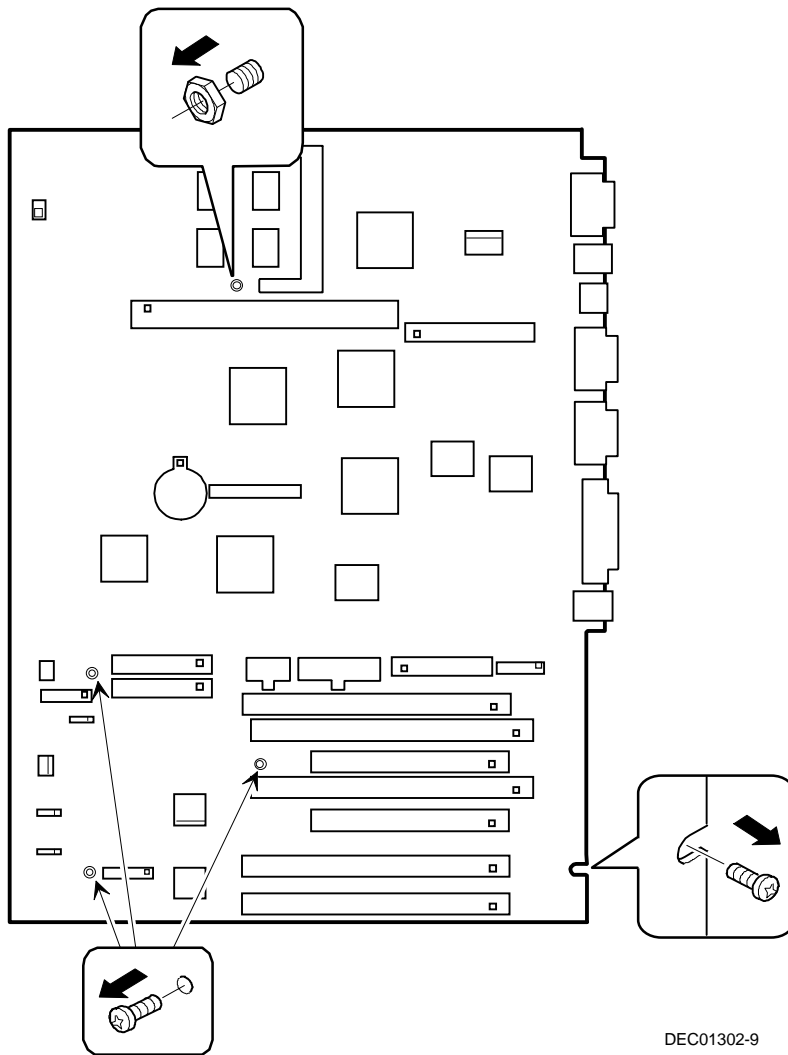

DEC01302-9

Figure 5-9. Removing the Main Logic Board

Removing the DIMMs

1. Turn off the workstation and monitor, and disconnect power from the workstation.
2. Remove the outside cover.
3. Press the DIMM retaining clips out.
4. Push the DIMM down and pull it out of the socket.

Parts Replacement

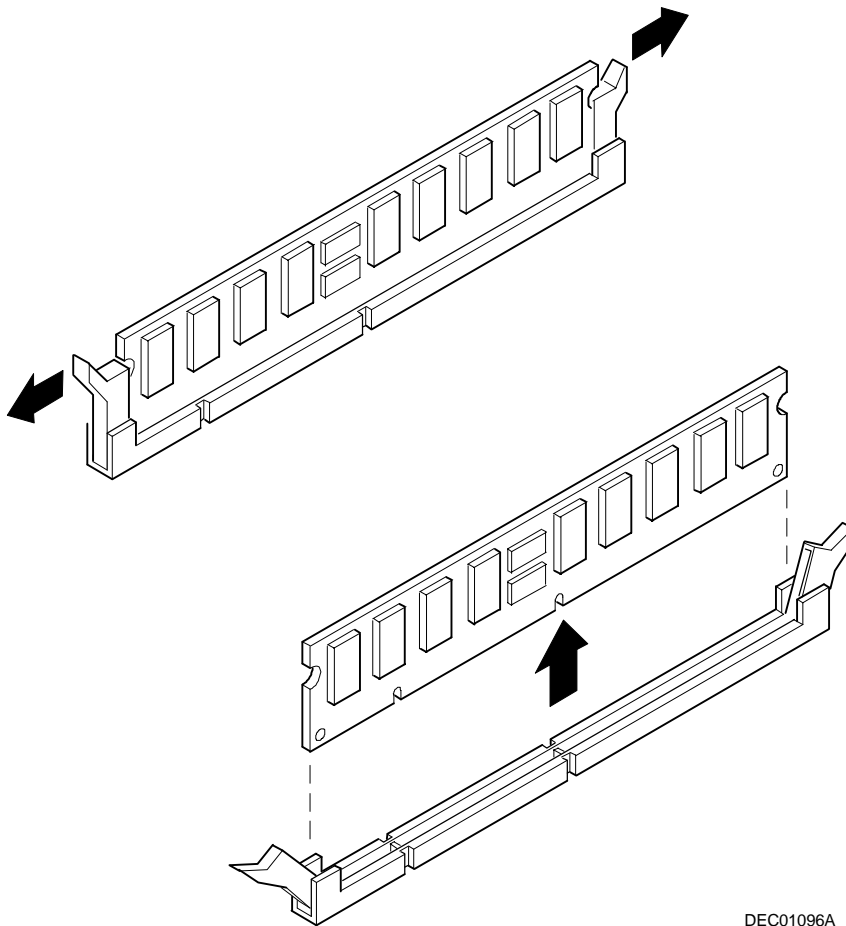

DEC01096A

Figure 5-10. Removing DIMMs

Removing the Lithium Battery

1. Record workstation configuration settings using the BIOS Setup utility.
2. Turn off the workstation and monitor, disconnect power from the workstation.
3. Remove the outside cover.
4. Remove the main logic board.
5. Remove the old battery by pushing on the battery socket where it says PUSH, then sliding the battery out.



WARNING: There is a danger of battery explosion if a lithium battery is incorrectly replaced. To prevent damage to the workstation, be sure the + side faces up when installing a new battery. Also, be sure you replace the battery with either a DIGITAL (P/N 12-41474-05), Toshiba (P/N CR2032), or equivalent 3 V dc lithium battery.

Depending on the locality, the workstation's battery might be considered hazardous waste. Make sure you follow any state or local statute to properly dispose of the old battery.

Parts Replacement

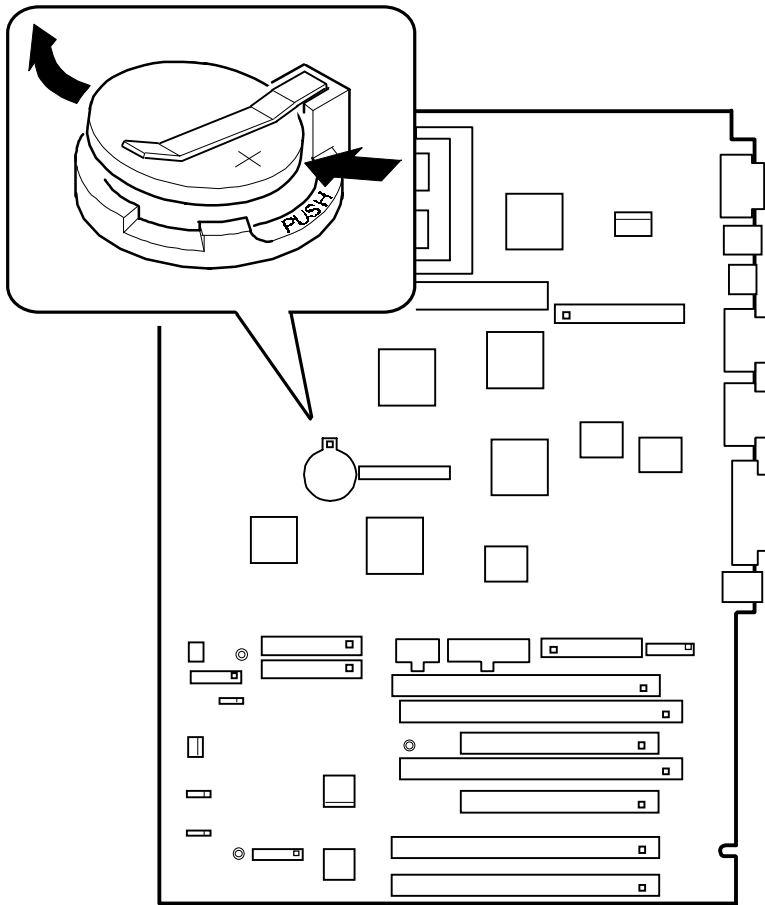

DEC01302-5

Figure 5-11. Removing the Lithium Battery

Removing the Processor Module

1. Turn off the workstation, monitor, and then disconnect power from the workstation.
2. Remove the outside cover.
3. Push out on the two plastic ejectors to release the Pentium® II processor module from the main logic board.

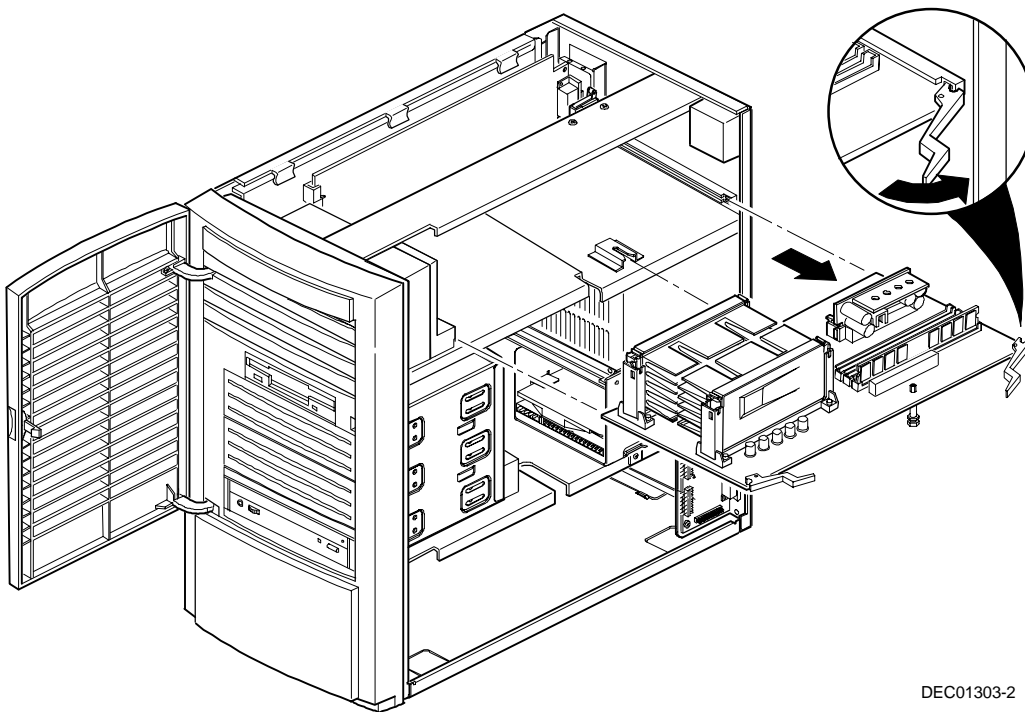

DIGITAL PERSONAL WORKSTATION

DEC01303-2

Figure 5-12. Removing the Pentium II Processor Module

Removing the Voltage Regulator Module (VRM)

1. Turn off the workstation, monitor, and then disconnect power from the workstation.
2. Remove the outside cover.
3. Remove the processor from the main logic board.
4. Push the clips to release the VRM from the processor module.
5. Remove the VRM by pulling it straight up.

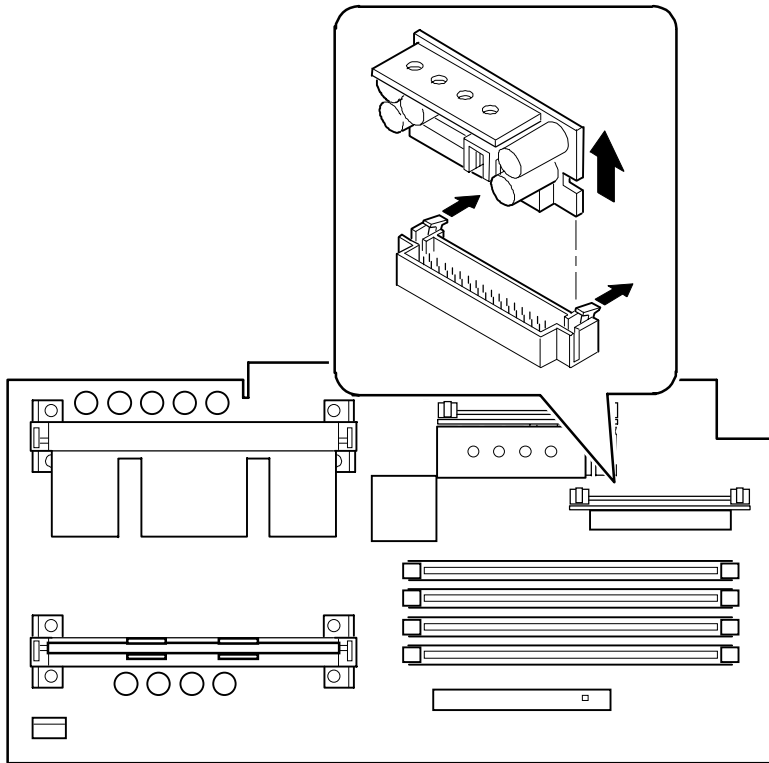

DEC01304-9

DIGITAL PERSONAL WORKSTATION

Figure 5-13. Removing the VRM

Removing the Terminator Module

1. Turn off your workstation and monitor.
2. Disconnect all external devices, ac power, and monitor power.
3. Remove the outside cover.



STATIC SENSITIVE: Static electricity collects on non-conductors such as paper, cloth, or plastic. A static discharge can be damaging even though it often cannot be seen or felt. To prevent damage to the processor:

- Touch the metal frame of your workstation to discharge any static electricity.
 - Keep the processor away from non-conductors.
4. Remove the processor module from the main logic board.
 5. Carefully grasp the terminator card by each end and pull up.

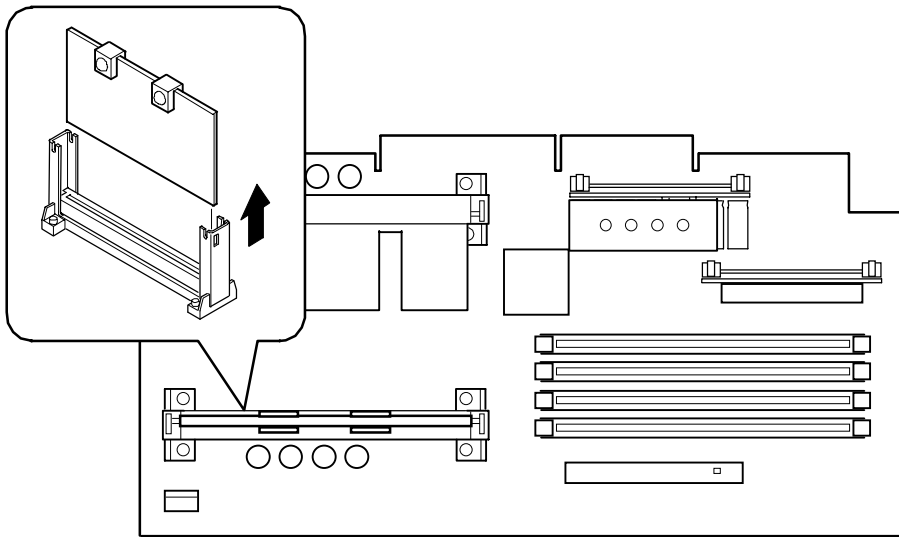

DEC01304-6

Figure 5-14. Removing the Terminator Module

Removing Expansion Boards



NOTE: It is not necessary to remove the main logic board to remove an expansion board.

1. Turn off the workstation, monitor, and then disconnect power from the workstation.
2. Remove the outside cover.
3. Remove the rear audio adapter.
4. Gently pull the expansion board from its socket.

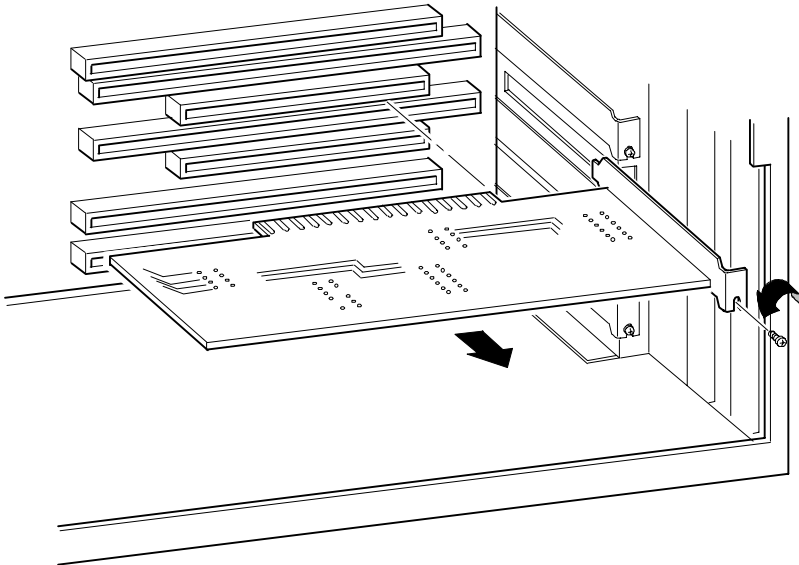

DEC01386-4

Figure 5-15. Removing Expansion Boards

Removing the Power Supply

1. Turn off the workstation, monitor, and then disconnect power from the workstation.
2. Remove the outside cover.
3. Disconnect the power cable from the backplane.
4. Disconnect all power cables from all devices.
5. Remove the screws from the power supply.
6. Remove the power supply.

Parts Replacement

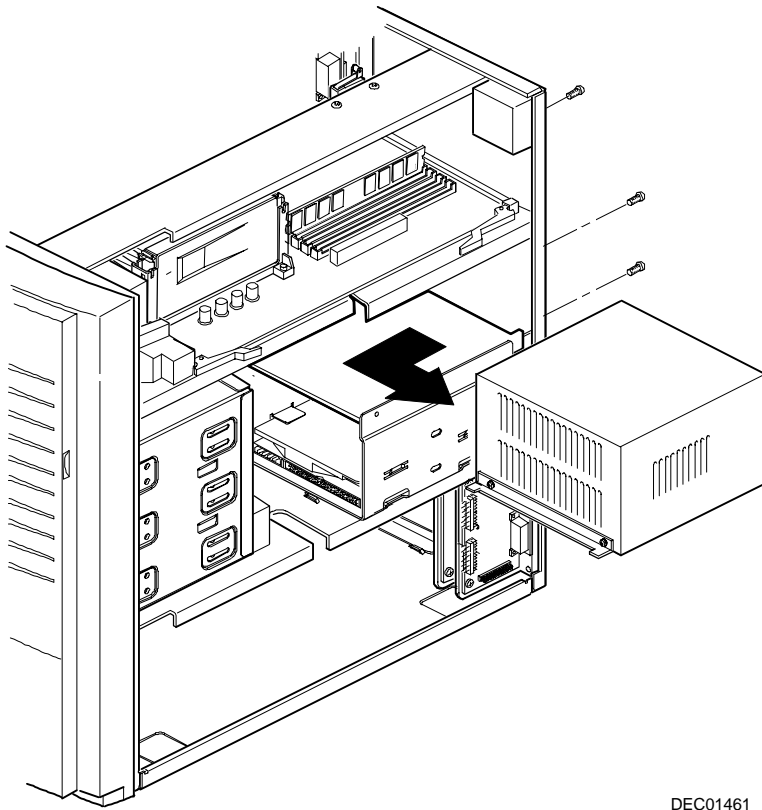

DEC01461

Figure 5-16. Removing the Power Supply

Removing the Control Panel Assembly and Cable

1. Turn off the workstation, monitor, and then disconnect power from the workstation.
2. Remove the outside cover.
3. Remove front bezel.
4. Push in on the tabs to disengage the control panel assembly.
6. Disconnect the cables from the control panel assembly noting the following when you reconnect.
 - White and black is the reset switch.
 - White, black, and red is the power switch.
 - Red and black is hard disk drive activity LED.
 - Yellow and black is the power LED. It is on top of the hard disk drive indicator.
7. Slide the cables through the slots.

The cables and their attached switch or indicators are now inside the workstation.
8. Unplug the cable connection from the backplane.
9. Rotate the speaker to remove it from the option card assembly.
10. Remove the control panel assembly cables from the workstation.

Parts Replacement

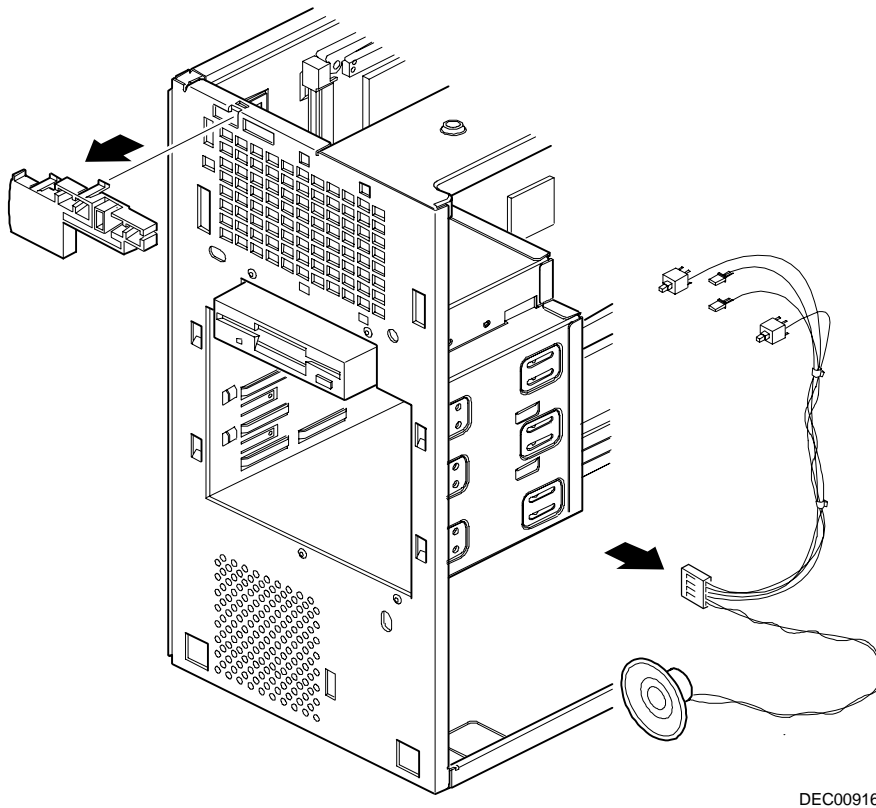

DEC00916

Figure 5-17. Removing the Control Panel Assembly and Cable

Removing the Option Card Assembly

1. Turn off the workstation, monitor, and then disconnect power from the workstation.
2. Remove the outside cover.
3. Push in on the tab to release the option card assembly.
4. Remove the option card assembly.

Parts Replacement

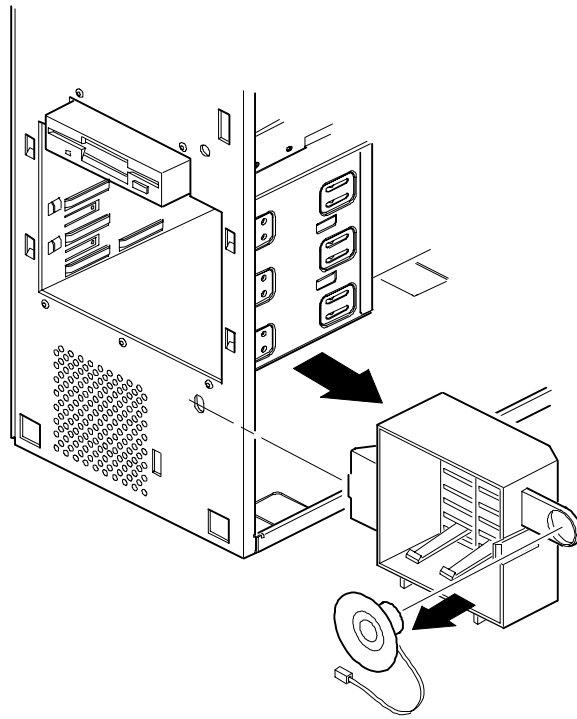

DEC01010

Figure 5-18. Removing the Option Card Assembly

Removing the Wire Assembly, Headphone/Microphone

1. Turn off the workstation, monitor, and then disconnect power from the workstation.
2. Remove the outside cover.
3. Remove the front bezel.
4. Push in on the tabs to disengage the control panel assembly.

The headphone and microphone connections are on a card inside the control panel assembly. This card is attached to the cable.

5. Remove the headphone and microphone card from the control panel assembly.

Push down on the headphone and microphone card to release it from the tabs and then slide the card back.

6. Unplug the other side of the cable from the backplane.
7. Slide the card through the appropriate front slot and then remove the headphone and microphone cable.

Parts Replacement

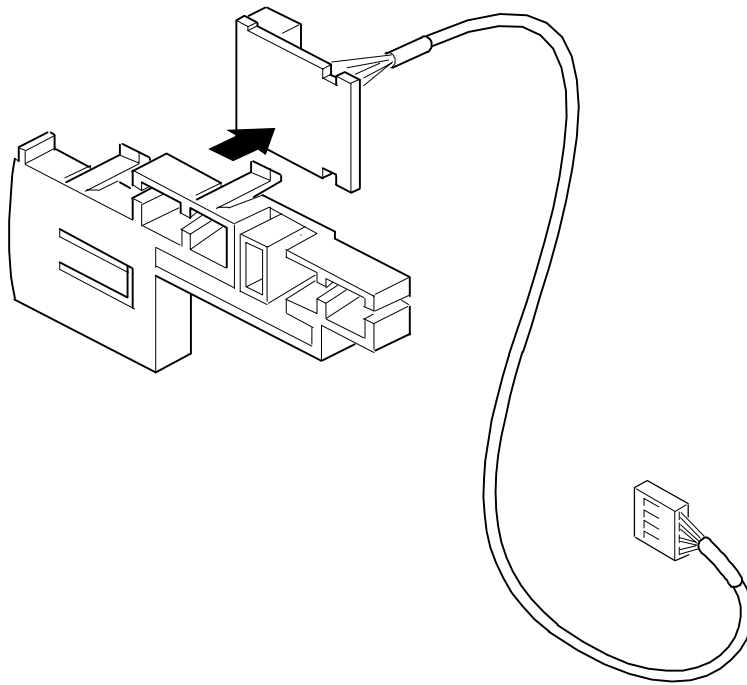

DEC00917

Figure 5-19. Removing the Wire Assembly, Headphone/Microphone

Removing the Front Bezel Door

1. Open the front bezel door so that the door is open 90 degrees.
2. With one hand near the top hinge area (top inside edge of the door), apply pressure to the top of the top hinge assembly.
3. With your other hand on the outside of the top of the door, apply pressure on the top-front of the door, rotating the top of the door frame clockwise towards the center of the workstation.
4. Once the top hinge has cleared, lift the door from the bottom hinge point.

Parts Replacement

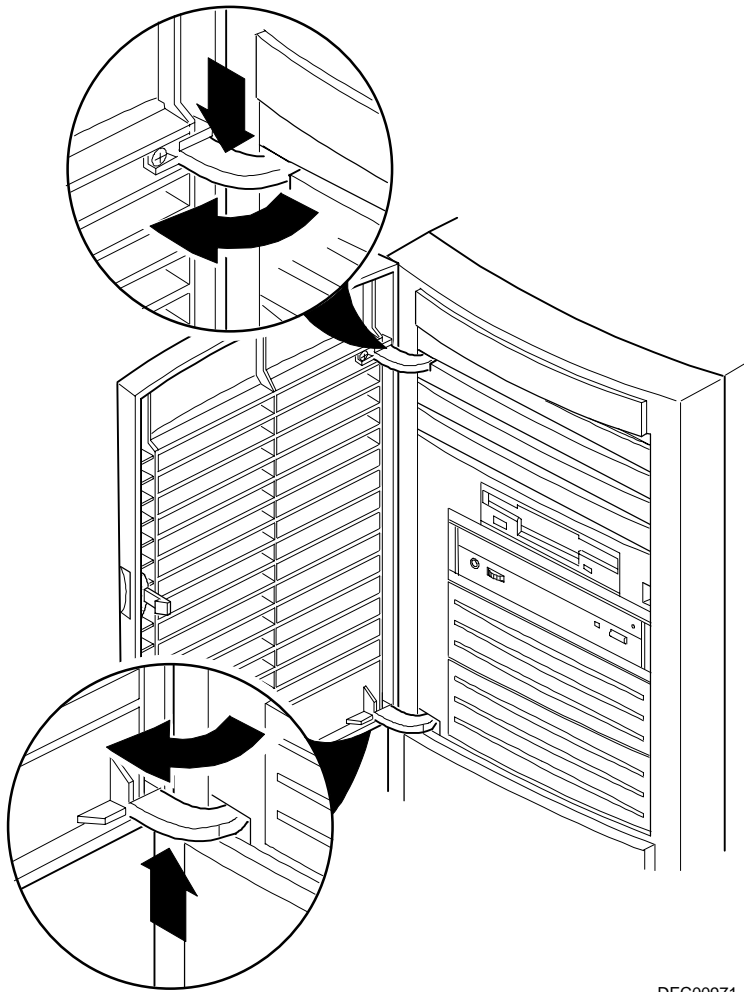

DEC00971

Figure 5-20. Removing the Front Bezel Door

Removing the Front Bezel

1. Turn off the workstation, monitor, and then disconnect power from the workstation.
2. Remove the outside cover.
3. Remove the front bezel.
4. From the top of the workstation, looking down towards the bottom of the front of the chassis, there should be two tabs from the front bezel that hold the bezel in place and secure it to the chassis. Find both tabs (one on the left and one on the right).
5. Gently pull the top of the bezel approximately an inch away from the top of the chassis.
6. Gently but firmly, pull up on the bezel to detach the bottom bezel mounts.

Parts Replacement

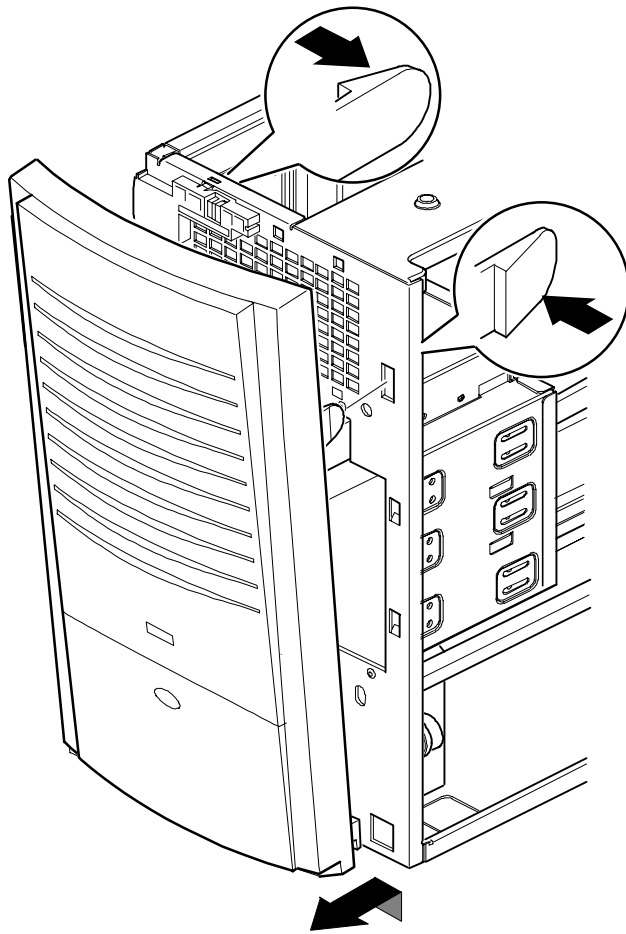

DEC00758-10

Figure 5-21. Removing the Front Bezel

Removing a 3½-Inch Device from Front Bay

1. Turn off the workstation, monitor, and then disconnect power from the workstation.
2. Remove the outside cover.
3. Remove the front bezel.
4. Disconnect all power and data cables.
5. If necessary, remove the EMI shield.
6. Remove the two screws holding the drive to the bay.
7. Remove the 3½-inch device, which includes the rail and the brackets.
8. Remove the rail from the device.
9. Remove the brackets from the device.

Parts Replacement

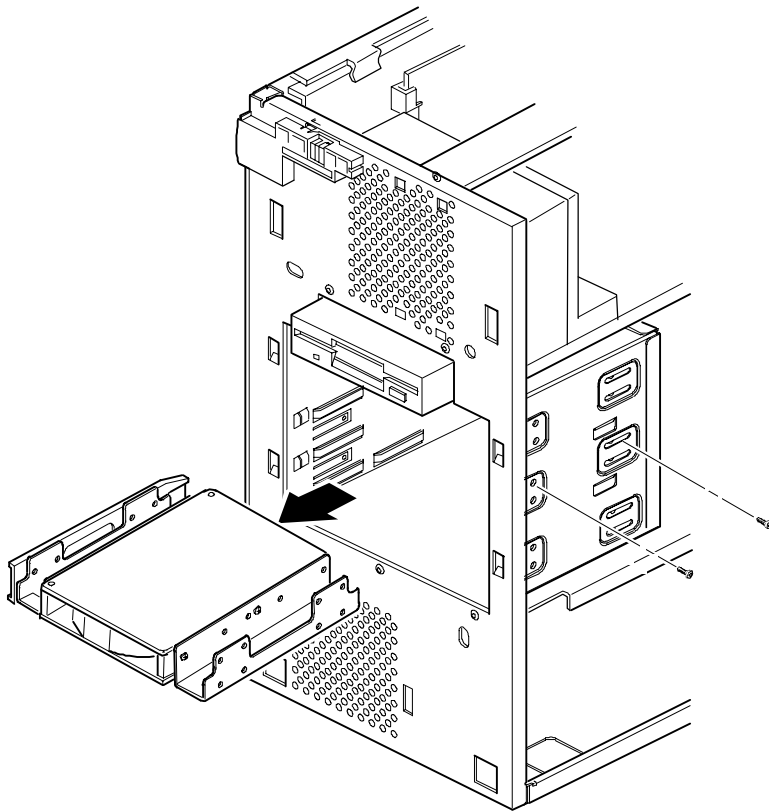

DEC01392-12

Figure 5-22. Removing a 3½ -inch Device from the Front Bay

Removing a 5¼-Inch Device

1. Turn off the workstation, monitor, and then disconnect power from the workstation.
2. Remove the outside cover.
3. Remove the front bezel.
4. Disconnect all power and data cables.
5. If necessary, remove the EMI shield.
6. Remove the two screws holding the drive to the bay.
7. Remove the 5¼-inch device, which includes the rail.
8. Remove the rail from the device.

Parts Replacement

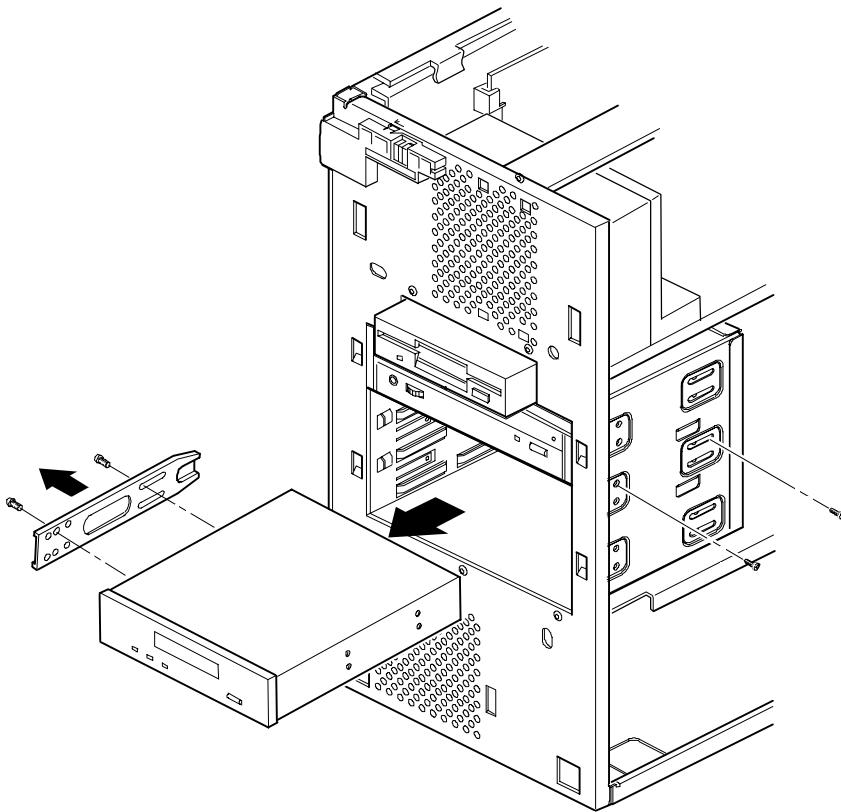

DEC01392-13

Figure 5-23. Removing a 5 1/4-Inch Device

Removing an Internal 3½-Inch Device

1. Turn off the workstation, monitor, and then disconnect power from the workstation.
2. Remove the outside cover.
3. Disconnect all power and data cables.
4. Remove the two screws securing the drive bay to the chassis.
5. Swing the device bay away from the chassis.
6. Remove the screws from the drive bay.
7. Remove the 3½-inch device.

Parts Replacement

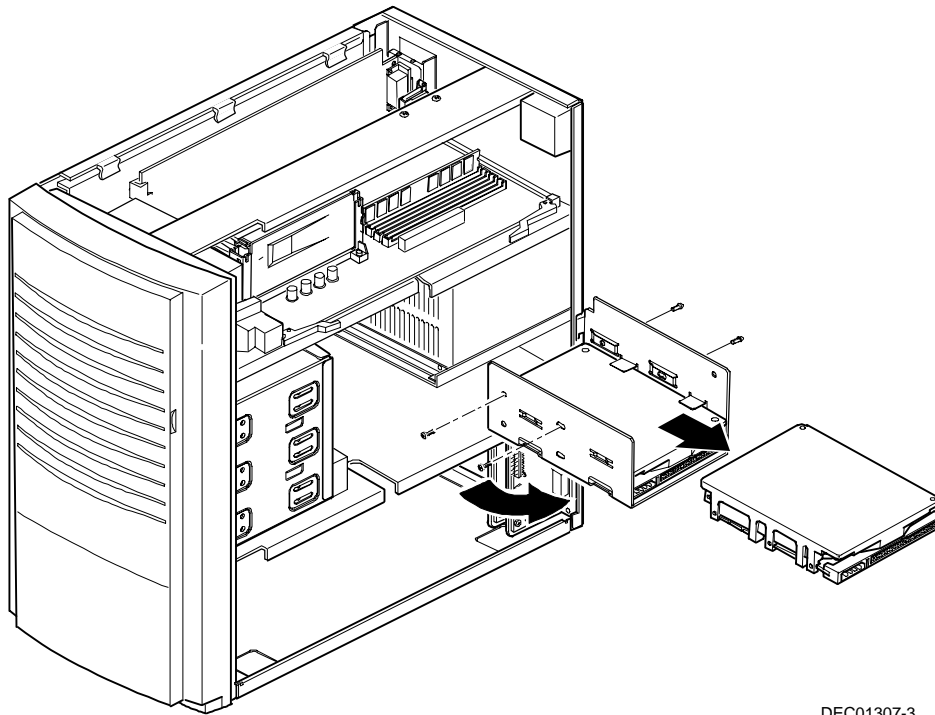

DEC01307-3

Figure 5-24. Removing an Internal 3½-Inch Device

IDE Drive Connections

Figure Legend	IDE Drive Component
A	Backplane IDE drive connection (primary)
B	Power connections
C	Power supply
D	Primary IDE hard disk drive
E	Primary IDE hard disk drive connections
F	Backplane IDE drive connection (secondary)
G	Secondary IDE hard disk drive connections
H ⁽¹⁾	CD-ROM drive

⁽¹⁾ The CD-ROM drive is connected to the secondary IDE port and configured as a master drive.

Parts Replacement

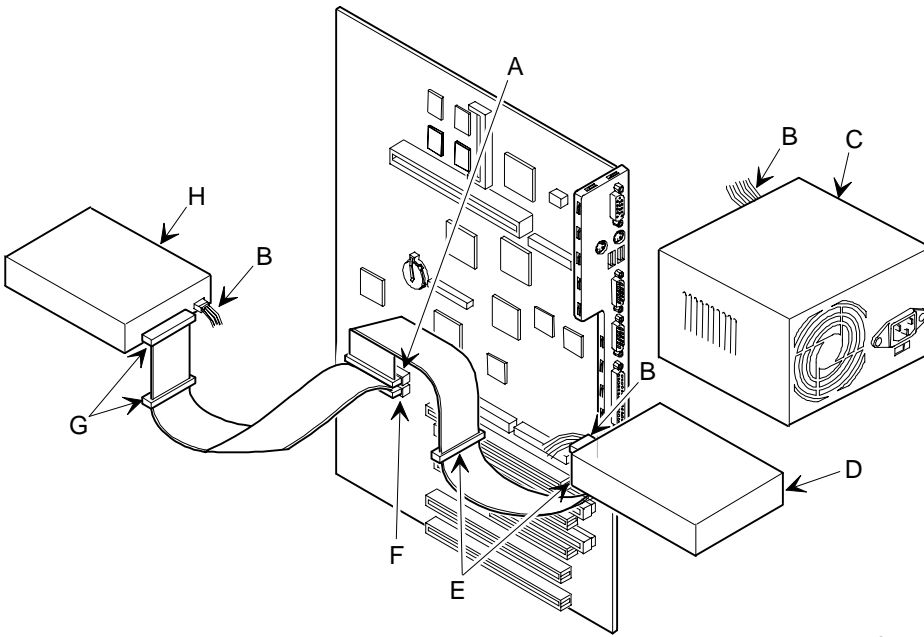

DEC01309

Figure 5-25. IDE Device Data Cable Connections

SCSI Drive Connections

Figure Legend	Component
A	CD-ROM drive (or other SCSI device)
B	Power connection
C	Single-ended active terminator
D	SCSI connectors
E	SCSI hard disk drive
F	SCSI controller connector (68-pin)
G	Power supply

Parts Replacement

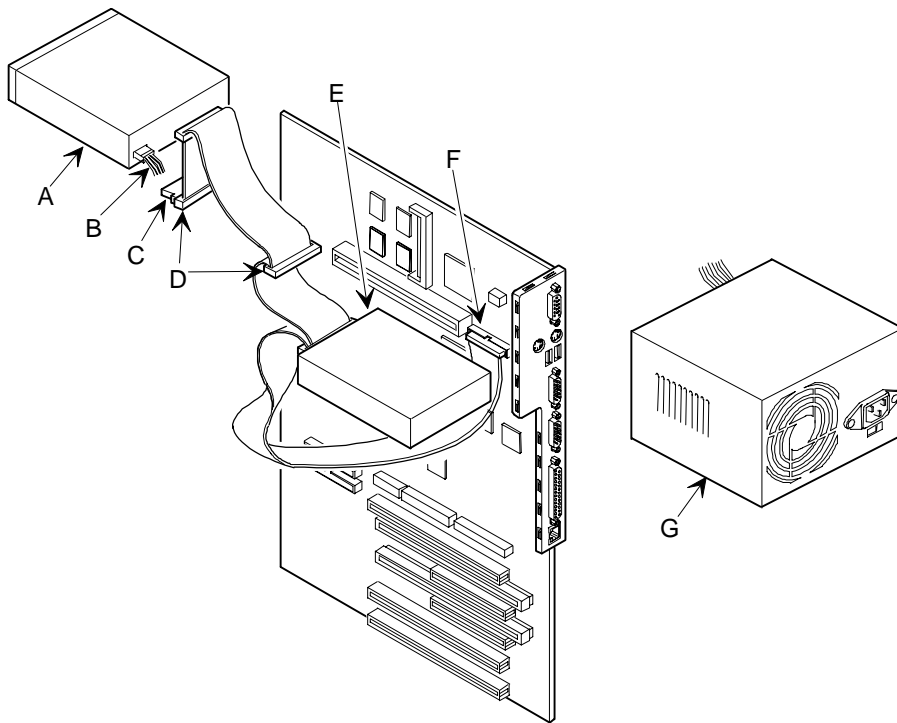

DEC01310

Figure 5-26. SCSI Device Data Cable Connections

Removing the Diskette Drive

1. Turn off the workstation, monitor, and then disconnect power from the workstation.
2. Remove the outside cover.
3. Remove the front bezel.
4. Remove all power and data cables from the diskette drive.
5. Remove the screws.
6. Remove the diskette drive.

Parts Replacement

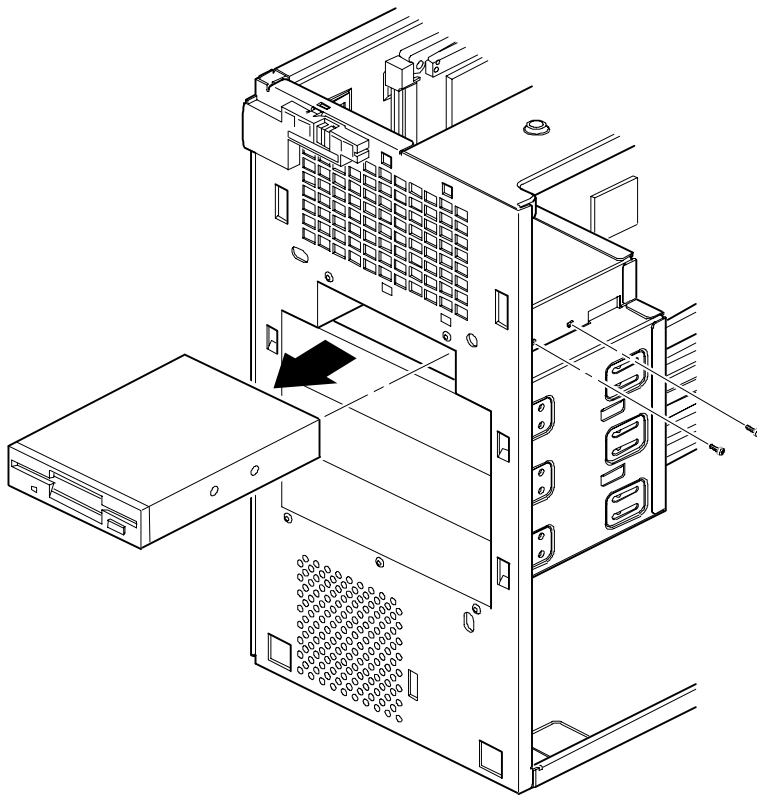

DEC00888-2

Figure 5-27. Removing the Diskette Drive

Diskette Drive Connections

Figure Legend	Diskette Drive Component
A	Power connection
B	Diskette drive
C	Diskette drive connections
D	Backplane diskette drive connection
E	Power supply



NOTE: When installing a CD-ROM drive, make sure that the hard disk drives are on one channel and the CD-ROM drive is on another. If you install a CD-ROM drive on the secondary/master channel and a hard disk drive on the secondary/slave channel, you might get a POST error and BIOS autodetect error. In addition, the hard disk drive on the secondary channel will be slowed to the same speed as the CD-ROM drive, resulting in poor hard disk drive performance and speed.

Parts Replacement

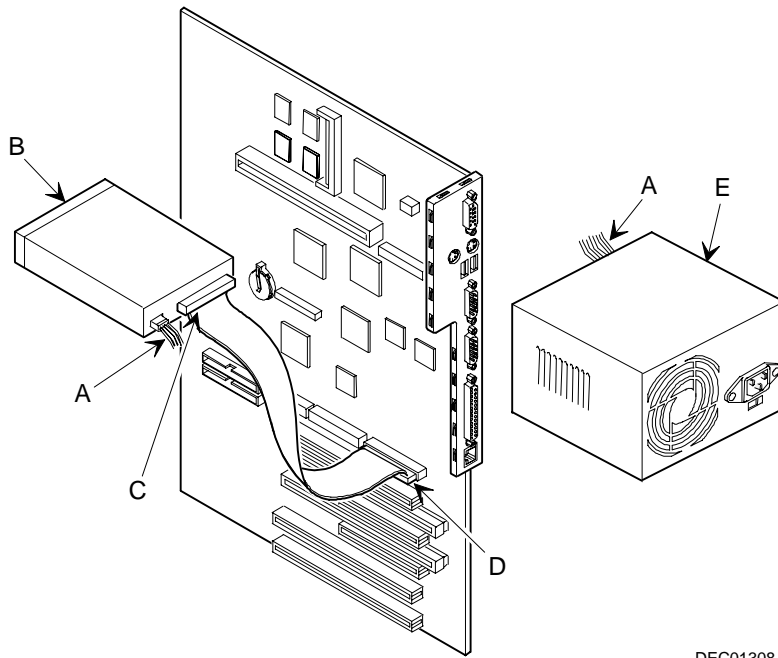

DEC01308

Figure 5-28. Diskette Device Data Cable Connections

Device Mapping **6**

Introduction

This chapter provides a series of tables listing mapping and address information related to workstation memory and various main logic board devices (keyboard controller, interrupt controller, DMA controller, etc.).

Your workstation's memory and address locations are allocated at the factory to operate within a standard PC environment. However, due to the number of optional devices and/or expansion boards that are available, sometimes memory and address locations need to be changed. For example, some network expansion boards require a specific memory location. If that location is already allocated, a memory conflict results and the expansion board will not operate as expected. Note that some memory, I/O and interrupt locations can be changed using the BIOS Setup utility.



CAUTION: Before changing any memory or address location, refer to the documentation supplied with the optional device, expansion board, or software application and make sure adequate information is available. If not, contact the option or software manufacturer for further information.

Device Mapping

Full Range Processor Memory Address Map

Range	Function	Size
0 to 9FFFFh	Base memory	640 KB
A0000h to BFFFFh	Video RAM	128 KB
C0000h to C7FFFh	Video BIOS	32 KB
C8000h to DFFFFh	BIOS extension ROM (AT bus used)	96 KB
E0000h to FFFFFh	PnP BIOS/APM BIOS	128 KB
100000h to 3FFFFFFFh	Extended memory	1023 MB

I/O Address Map

Range (hexadecimal)	Function
000 - 00F	DMA controller one
020 - 021	Interrupt controller one
040 - 043	Interval timer
060 - 06F	Keyboard controller
070 - 07F	Real-Time Clock (RTC), NMI
080 - 08F	DMA page register
0A0 - 0A1	Interrupt controller two
0C0 - 0CF	DMA controller two
0F0	Clear math co-processor busy
0F1	Reset math co-processor
0F8 - 0FF	Math co-processor
170 - 177	Secondary IDE controller
1F0 - 1F7	Primary IDE controller
200 - 207	Audio, Joystick
220 - 22F	Audio Sound Blaster Pro compatible
278 - 27A	LPT2
2E8 - 2EF	COM4

continued

Device Mapping

Range (hexadecimal)	Function
2F8 - 2FF	COM2
300 - 301	Audio, MP401
378 - 37A	LPT1
388 - 38B	Audio, FM music synthesizer
3BC - 3BE	LPT3
3E8 - 3EF	COM3
3F0 - 3F7	Diskette (floppy disk) controller
3F6 - 3F7	Primary/secondary IDE controller (alt status, device address)
3F8 - 3FF	COM1
4D0	Edge/level control register - INTCNTRL1
4D1	Edge/level control register - INTCNTRL2
530 - 533	Audio, Windows Sound System
CF8 - CFF	PCI configure space control register
F00 - F07	Audio, Control Port
22-3F	Programming chip select

Interrupt Levels

Interrupt Number	Interrupt Source
IRQ0	Timer tick
IRQ1	Keyboard controller
IRQ2	Cascade interrupt
IRQ3	COM2, COM4, if enabled
IRQ4	COM1, COM3, if enabled
IRQ5	Audio, if enabled
IRQ6	Diskette (floppy disk) drive, if enabled
IRQ7	LPT1, LPT3, if enabled
IRQ8	Real Time Clock (RTC)
IRQ9	(PCI device or reserved) default video
IRQ10	(PCI device or reserved) default SCSI
IRQ11	(PCI device or reserved) default network
IRQ12	Mouse interrupt, if enabled
IRQ13	Math co-processor
IRQ14	IDE primary, if enabled
IRQ15	IDE secondary, if enabled

DMA Channel Assignment

Channel	Controller	Function
0	1	Refresh
1	1	Audio (if enabled)
2	1	Diskette (floppy disk) controller, if enabled
3	1	ECP
4	2	Cascade DMA
5	2	Playback audio (if enabled)
6	2	Not used
7	2	Not used

Service Notes

A

DIGITAL PERSONAL WORKSTATION

Service Notes

Service Notes

DIGITAL PERSONAL WORKSTATION

Service Notes